

"06

ERSATZTEILKATALOG SPARE PARTS MANUAL

Parts List 2006



HUSABERG
STROKE FORCE

TELEGABEL WP FE
FRONT FORK WP FE

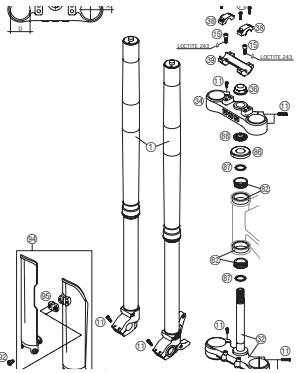

SEITE
Page
6

TELEGABEL WP FS
FRONT FORK WP FS

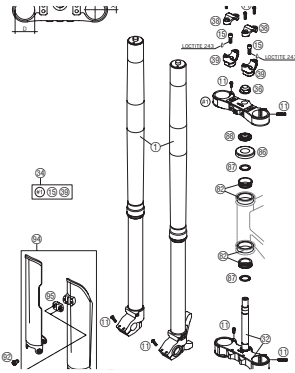

SEITE
Page
7

GABELBEINE FE
FORK LEGS FE

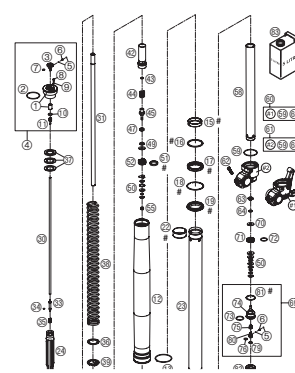

SEITE
Page
8

GABELBEINE FS
FORK LEGS FS

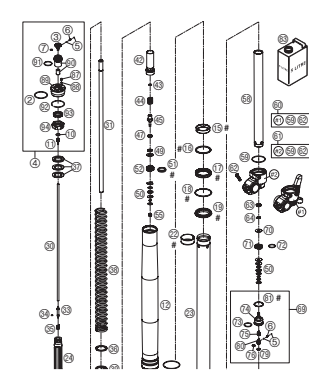

SEITE
Page
11

LENKER, ARMATUREN
HANDLEBAR, CONTROLS

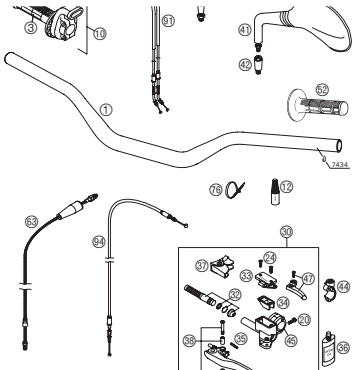

SEITE
Page
14

HANDBREMSZYLINDER FE
HAND BRAKE CYLINDER FE

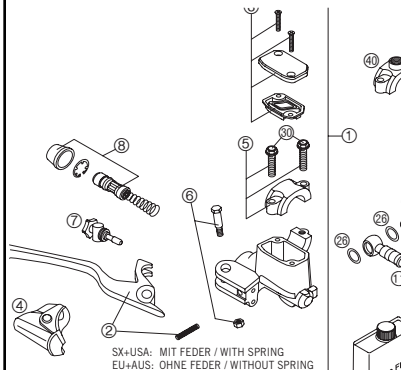

SEITE
Page
15

HANDBREMSZYLINDER FE USA
HAND BRAKE CYLINDER FE USA

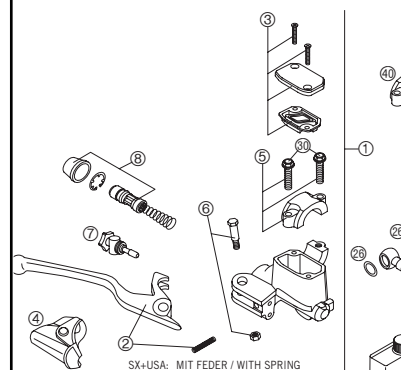

SEITE
Page
16

HANDBREMSZYLINDER FS
HAND BRAKE CYLINDER FS

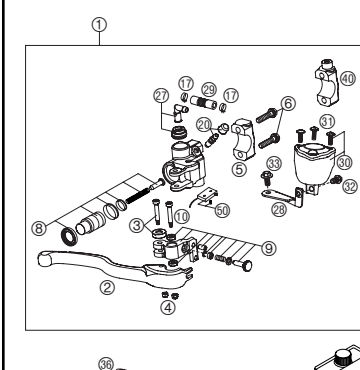

SEITE
Page
17

RAHMEN
FRAME

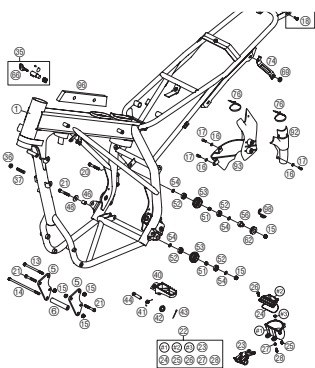

SEITE
Page
18

SEITENSTÄNDER FE, FS
SIDE STAND FE, FS

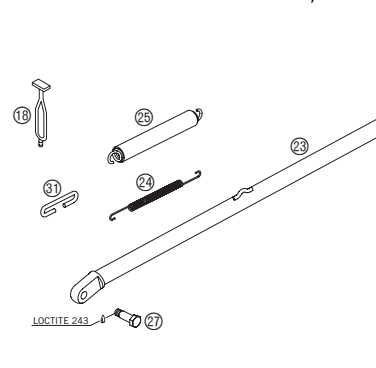

SEITE
Page
20

SCHWINGARM, KETTENSCHUTZ
SWINGARM, CHAIN GUARD

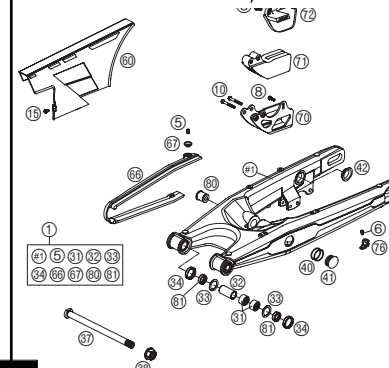

SEITE
Page
21

FUSSBREMSHEBEL
REAR BRAKE CONTROL

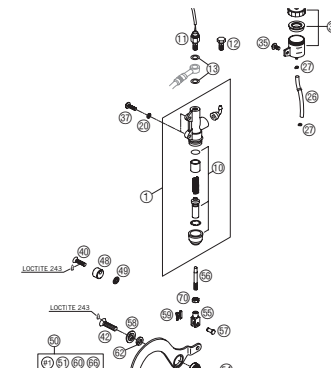

SEITE
Page
22

FEDERBEIN WP
SHOCK ABSORBER WP

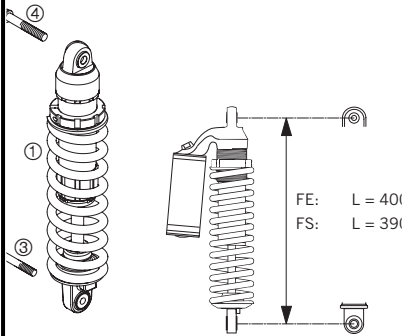

SEITE
Page
23

FE: L = 40(
FS: L = 39(
)

FEDERBEIN ZERLEGT FE
SHOCK ABSORBER DISASSEMBLED FE

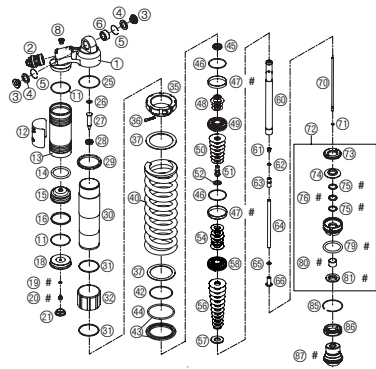

SEITE
Page
24

FEDERBEIN ZERLEGT FS
SHOCK ABSORBER DISASSEMBLED FS

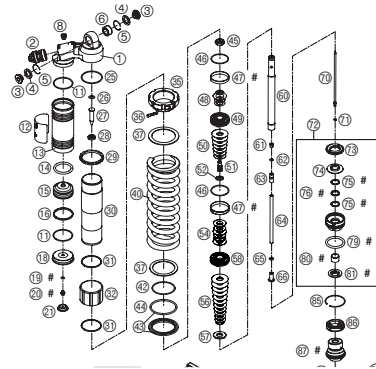

SEITE
Page
27

KRÜMMER, ZWISCHENROHR
EXHAUST PIPE, INTERM. TUBE

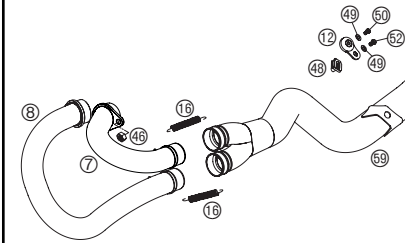

SEITE
Page
30

ENDDÄMPFER
EXHAUST SILENCER

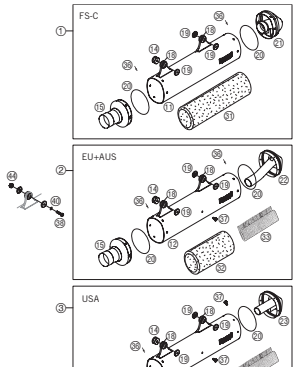

SEITE
Page
31

LUFTFILTER
AIR FILTER

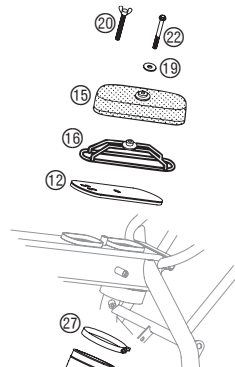

SEITE
Page
32

TANK, SITZBANK, VERKLEIDUNG
TANK, SEAT, COVER

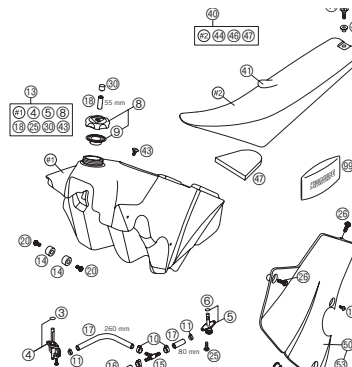

SEITE
Page
33

MASKE, KOTFLÜGEL
MASK, FENDERS

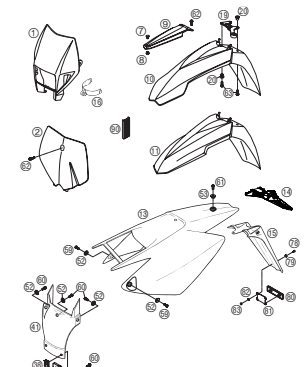

SEITE
Page
34

DEKOR
DECAL

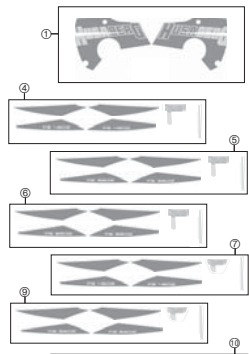

SEITE
Page
35

VORDERRAD 21" FE
FRONT WHEEL 21" FE

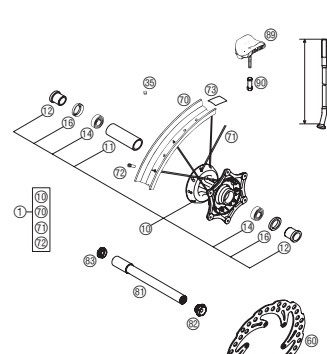

SEITE
Page
36

VORDERRAD 17" FS
FRONT WHEEL 17" FS

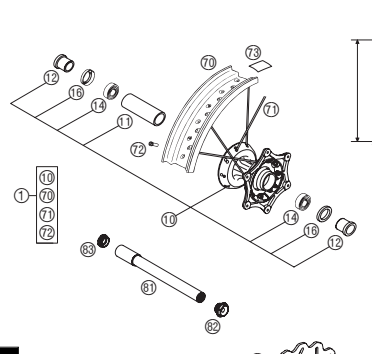

SEITE
Page
37

BREMSZANGE VORNE FE
BRAKE CALIPER FRONT FE

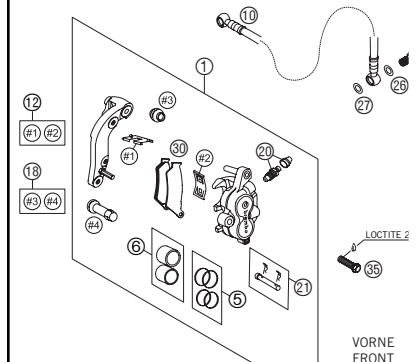

SEITE
Page
38

LOCTITE 2
VORNE
FRONT

**BREMSZANGE VORNE FS
BRAKE CALIPER FRONT FS**

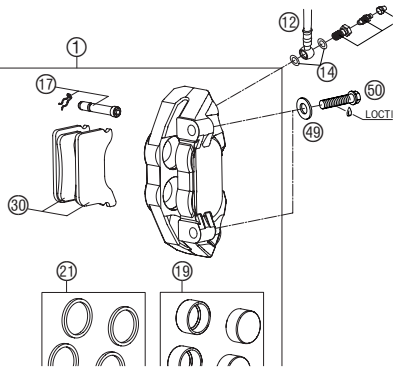

SEITE
Page
39

**HINTERRAD 18" FE
REAR WHEEL 18" FE**

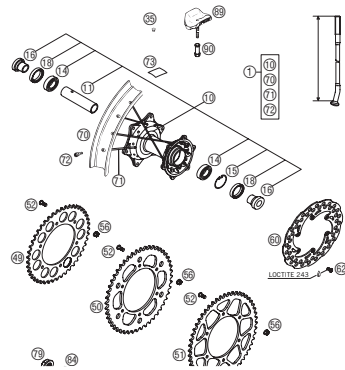

SEITE
Page
40

**HINTERRAD 17" FS-E
REAR WHEEL 17" FS-E**

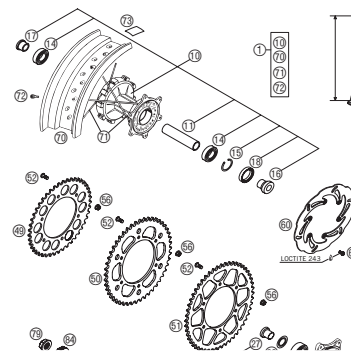

SEITE
Page
42

**HINTERRAD 17" FS-C
REAR WHEEL 17" FS-C**

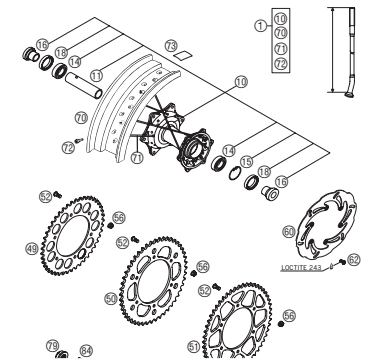

SEITE
Page
43

**BREMSZANGE HINTEN
BRAKE CALIPER REAR**

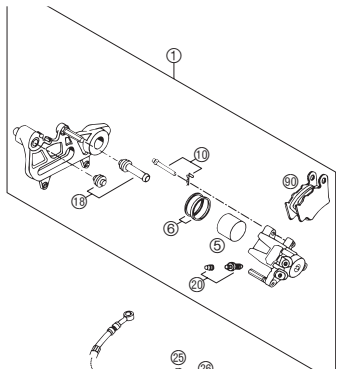

SEITE
Page
44

**SCHEINWERFER, RÜCKLICHT, BLINKER
HEAD LIGHT, REAR LIGHT, FLASHER**

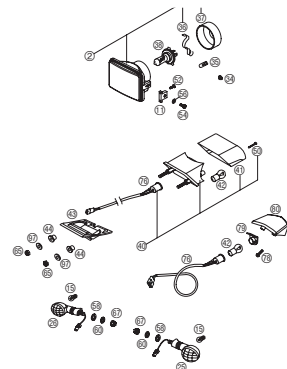

SEITE
Page
45

**TACHOANLAGE
SPEEDOMETER**

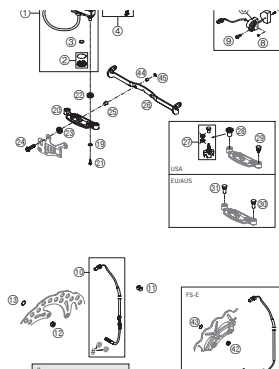

SEITE
Page
46

**KABELSTRANG USA
WIRING HARNESS USA**

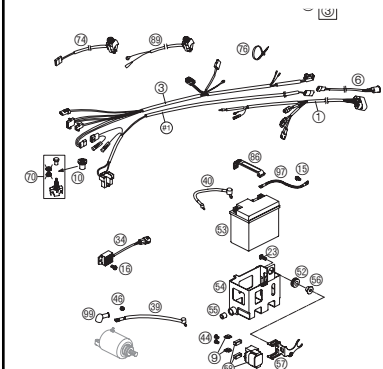

SEITE
Page
47

**KABELSTRANG EU+AUS
WIRING HARNESS EU+AUS**

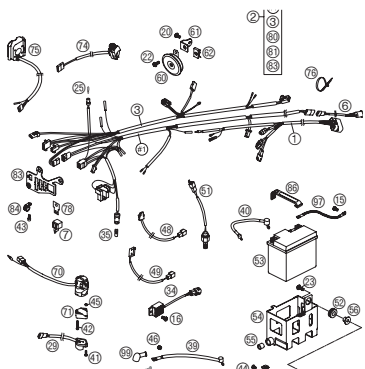

SEITE
Page
48

**ZUBEHÖR
ACCESSORIES**

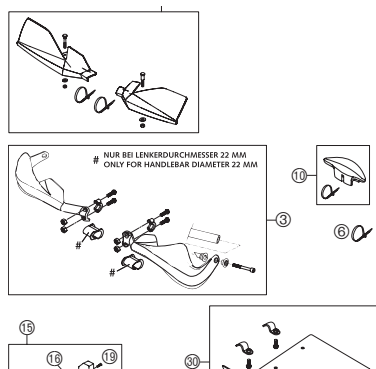

SEITE
Page
50

**MOTORGEHÄUSE
ENGINE CASE**

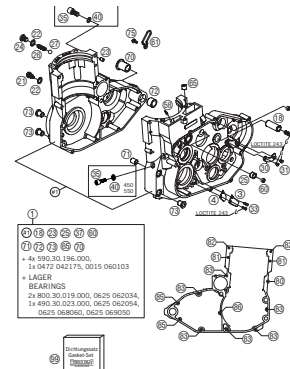

SEITE
Page
51

**KUPLUNGSDECKEL
CLUTCH COVER**

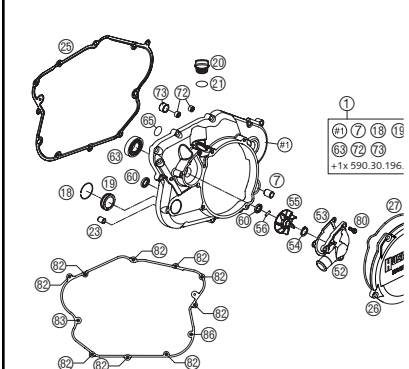

SEITE
Page
52

KURBELWELLE, KOLBEN
CRANKSHAFT, PISTON

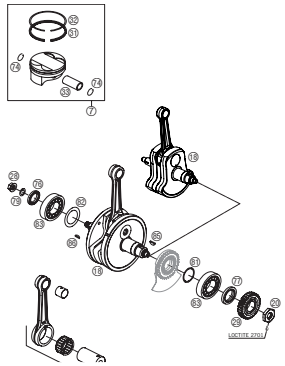

SEITE
Page
53

AUSGLEICHSWELLE
BALANCER SHAFT

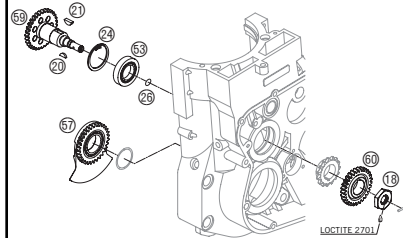

SEITE
Page
54

ZYLINDERLAUFBÜCHSE
CYLINDER LINER

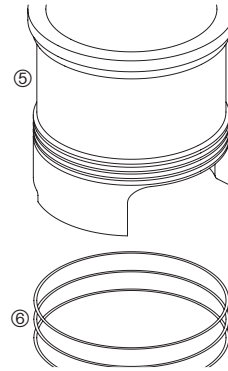

SEITE
Page
55

ZYLINDERKOPF
CYLINDER HEAD

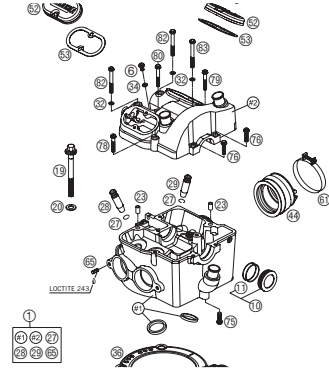

SEITE
Page
56

VENTILTRIEB
VALVE DRIVE

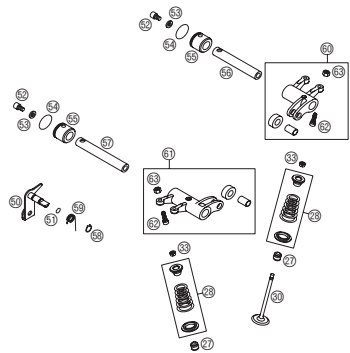

SEITE
Page
57

STEUERTRIEB
TIMING VALVE

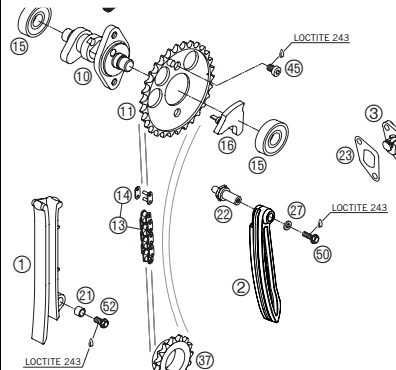

SEITE
Page
58

SCHMIERSYSTEM
LUBRICATING SYSTEM

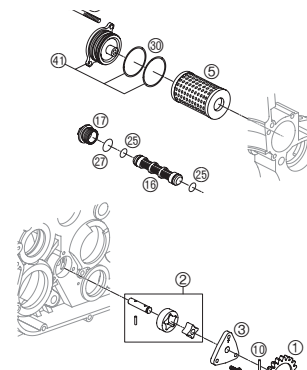

SEITE
Page
59

MOTORENTLÜFTUNG
BREATHER SYSTEM

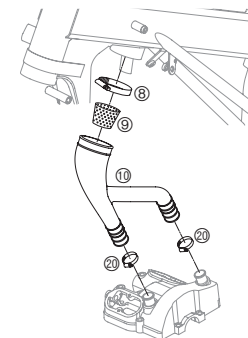

SEITE
Page
60

VERGASER KEIHIN
CARBURETOR KEIHIN

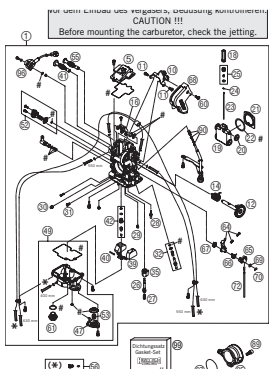

SEITE
Page
61

ZÜNDANLAGE KOKUSAN
IGNITION SYSTEM KOKUSAN

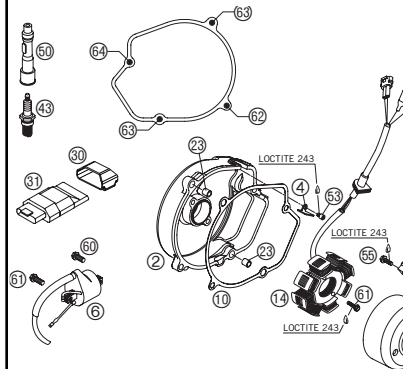

SEITE
Page
64

ELEKTROSTARTER
ELECTRIC STARTER

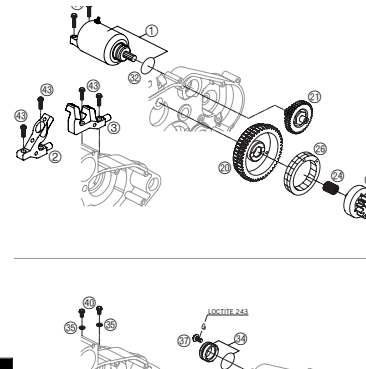

SEITE
Page
65

KUPPLUNG
CLUTCH

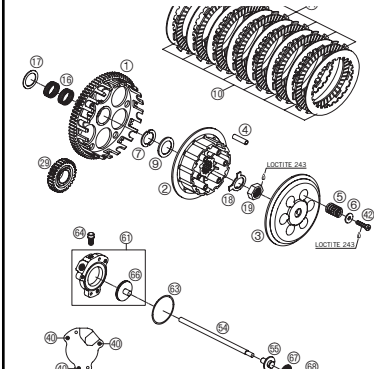

SEITE
Page
66

KICKSTARTER KICKSTARTER

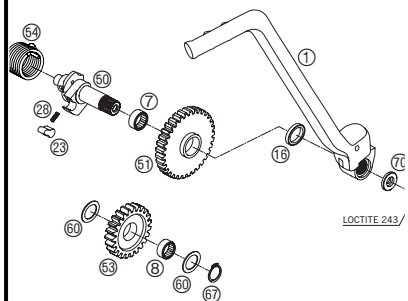

SEITE
Page
67

LOCTITE 243/

GETRIEBE I - ANTRIEBSWELLE TRANSMISSION I - MAIN SHAFT

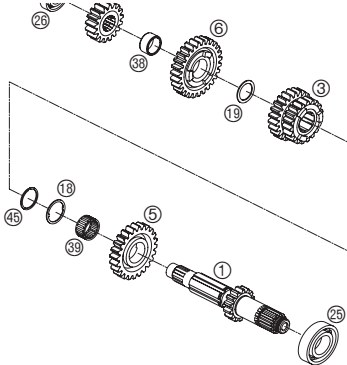

SEITE
Page
68

GETRIEBE II - ABTRIEBSWELLE TRANSMISSION II - COUNTERSHAFT

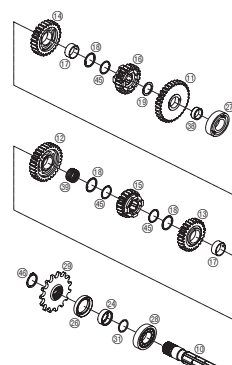

SEITE
Page
69

SCHALTUNG SHIFTING MECHANISM

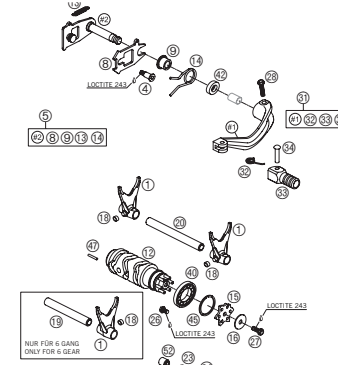

SEITE
Page
70

PLATZ FÜR 6. GANG,
ONLY FOR 6 GEAR

KÜHLSYSTEM FS-C COOLING SYSTEM FS-C

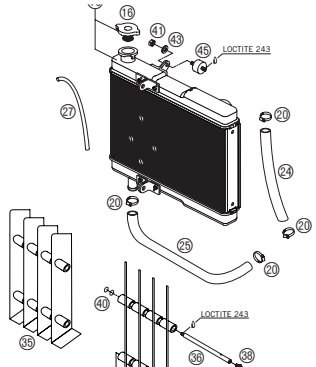

SEITE
Page
71

KÜHLSYSTEM FE, FS-E COOLING SYSTEM FE, FS-E

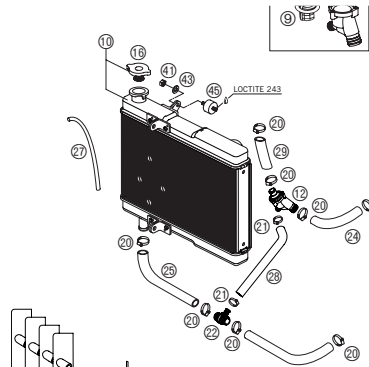

SEITE
Page
72

SPEZIALWERKZEUGE SPECIAL TOOLS

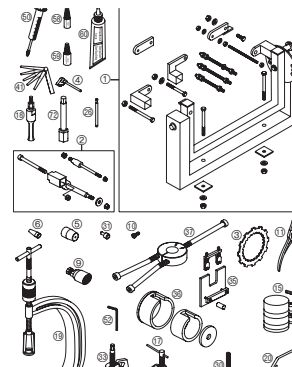

SEITE
Page
73

HUSABERG - a company of the KTM Group behält sich das Recht vor, Ausrüstung, technische Angaben, Farben, Materialien, Dienstleistungsangebote, Serviceleistungen und ähnliche Dinge ohne vorheriger Ankündigung und ohne Angabe von Gründen zu ändern bzw. ersatzlos zu streichen, sowie die Fertigung eines bestimmten Modells ohne vorherige Ankündigung einzustellen. Für Druckfehler übernehmen wir keine Haftung.

© by HUSABERG - a company of the KTM Group, AUSTRIA
Alle Rechte vorbehalten.

HUSABERG - a company of the KTM Group reserves the right to modify any equipment, technical specifications, colors, materials, services offered and rendered, and the like so as to adapt them to local conditions without previous announcement and without giving reasons, or to cancel any of the above items without substituting them with others. It shall be acceptable to stop manufacturing a certain model without previous announcement. In the event of such modifications, please ask your local KTM dealer for information. We shall not be held liable for any printing errors.

© by HUSABERG - a company of the KTM Group, AUSTRIA
All rights reserved.

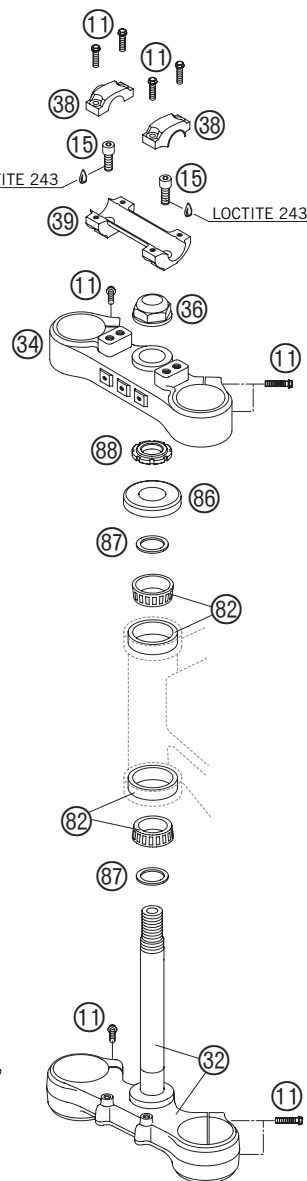
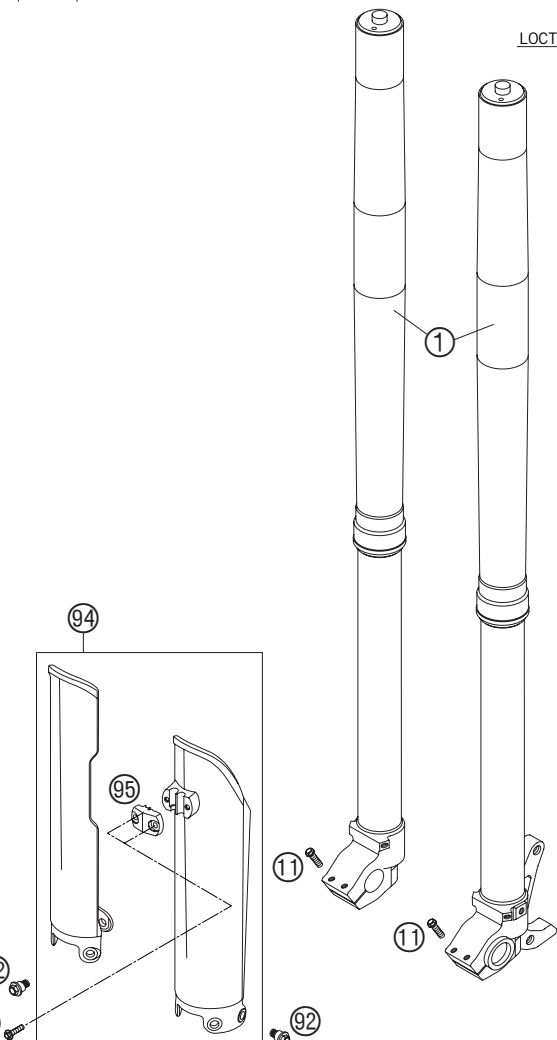
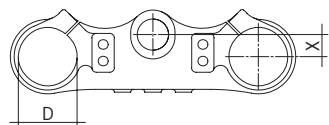
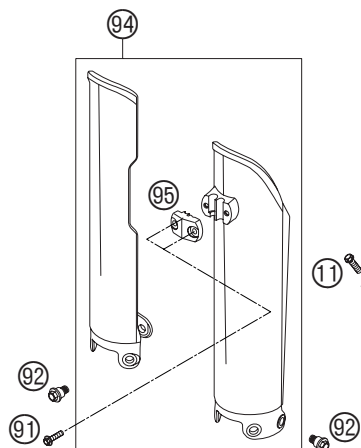
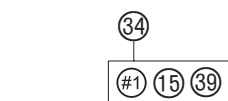
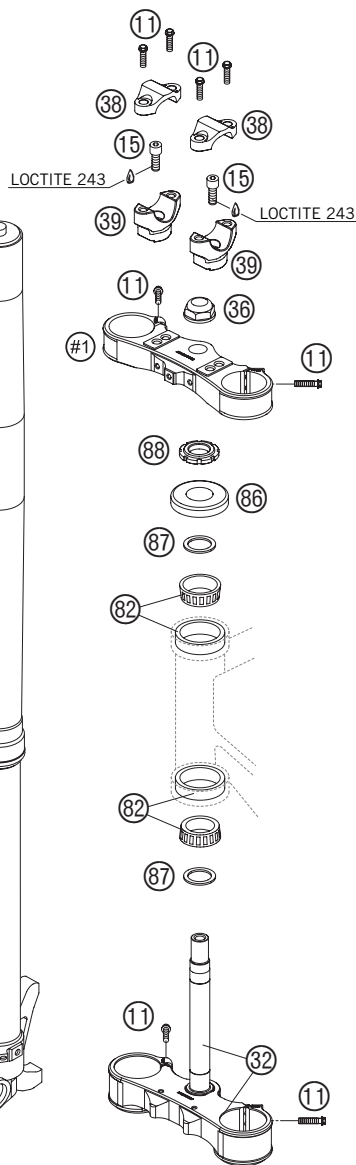
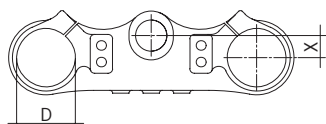

FIG	TEILNR/PARTNR	BEZEICHNUNG	DESCRIPTION	QTY
1*	1445.7B02	GABEL D=48 MA FE 2006	FRONT FORK D=48 MA FE 2006	1
11	0015 080303	SK.BUNDSCHRAUBE M 8X30 SW=10	HH COLLAR SCREW M 8X30 WS=10	16
15	0912 100250	ISK.SCHR.DIN6912 M10X25 10.9 S	AH SCREW DIN6912-M10X25,10.9,L	2
32	800.01.032.022	GABELBRÜCKE UNT. KPL.X=22/D=60	BOT.TRIPLE CLAMP CPL.X=22/D=60	1
34	800.01.034.022	GABELBRÜCKE OBEN X=22/D=54 04	TOP TRIPLE CLAMP X=22/D=57 04	1
36	800.01.036.000	BUNDMUTTER M22X1/5H/SW27 ALU	COLLAR SCREW M22X1/5H/WS27 ALU	1
38	590.01.038.200	LENKERKLEMMBRÜCKE D=28MM 2000	HANDLEBAR CLAMP D=28MM 2000	2
39	590.01.039.100	LENKERAUFNAHME 28MM SC'99	HANDLEBAR SUPPORT 28MM SC'99	1
82*	800.01.080.000	KEGELROLLENL. STEUERKOPF KPL.	TAPERED ROLLER BEARING CPL.	2
86	542.01.086.000	SCHUTZRING	STEERING HEAD COVER	1
87	800.01.087.000	DISTANZRING STEUERKOPF 04	SPACER STEERING HEAD 04	2
88	800.01.088.100	EINSTELLMUTTER STEUERKOPF 05	ADJUSTING NUT STEERING HEAD 05	1
91	0017 060204	EJOT PT SCHRAUBE K60X20AL SW=6	EJOT PT SCREW K60X20 ALU WS=6	2
92	590.01.092.050	SONDERSCHRAUBE M6X12,5 SW=8	SPECIAL SCREW M6X12,5 WS=8	6
94	590.01.094.000/30	GABELSCHUTZ LI+RE SCHWARZ 02	FORK PROTECT. L/S+R/S BLACK 02	1
95	590.01.085.100	KLEMME F.TACHOKABEL D=6MM 2001	CLAMP F.SPEED.CABLE D=6MM 2001	1

FIG	TEILNR/PARTNR	BEZEICHNUNG	DESCRIPTION	QTY
1*	1445.7B03	GABEL D=48 MA FS 2006	FRONT FORK D=48 MA FS 2006	1
11	0015 080303	SK.BUNDSCHRAUBE M 8X30 SW=10	HH COLLAR SCREW M 8X30 WS=10	18
15*	0912 100356	ISK.SCHR. DIN6912 M10X35 10.9	AH SCREW DIN6912-M10X35 10.9	2
32	800.01.032.116	GABELBRÜCKE UNT. KPL.X=16/D=60	BOT.TRIPLE CLAMP CPL.X=16/D=60	1
34*	800.01.035.017	GABELBR. OB. VMT. X=17/D=57 05	TOP T.CLAMP CPL. X=17/D=57 05	1
36	800.01.036.000	BUNDMUTTER M22X1/5H/SW27 ALU	COLLAR SCREW M22X1/5H/WS27 ALU	1
38	594.01.038.000	LENKERKLEMMBRÜCKE 28MM 05	HANDLEBAR CLAMP 28MM 05	2
39*	594.01.039.037	LENKERAUFN. D=28MM H=37MM 05	HANDLEB.SUPP. D=28MM H=37MM 05	2
82*	800.01.080.000	KEGELROLLENL. STEUERKOPF KPL.	TAPERED ROLLER BEARING CPL.	2
86	542.01.086.000	SCHUTZRING	STEERING HEAD COVER	1
87	800.01.087.000	DISTANZRING STEUERKOPF 04	SPACER STEARING HEAD 04	2
88	800.01.088.100	EINSTELLMUTTER STEUERKOPF 05	ADJUSTING NUT STEERING HEAD 05	1
91	0017 060204	EJOT PT SCHRAUBE K60X20AL SW=6	EJOT PT SCREW K60X20 ALU WS=6	2
92	590.01.092.050	SONDERSCHRAUBE M6X12,5 SW=8	SPECIAL SCREW M6X12,5 WS=8	6
94	590.01.094.000/30	GABELSCHUTZ LI+RE SCHWARZ 02	FORK PROTECT. L/S+R/S BLACK 02	1
95	582.01.085.000	KLEMME F.TACHOKABEL D=8MM 2001	CLAMP F.SPEED CABLE D=8MM 2001	1



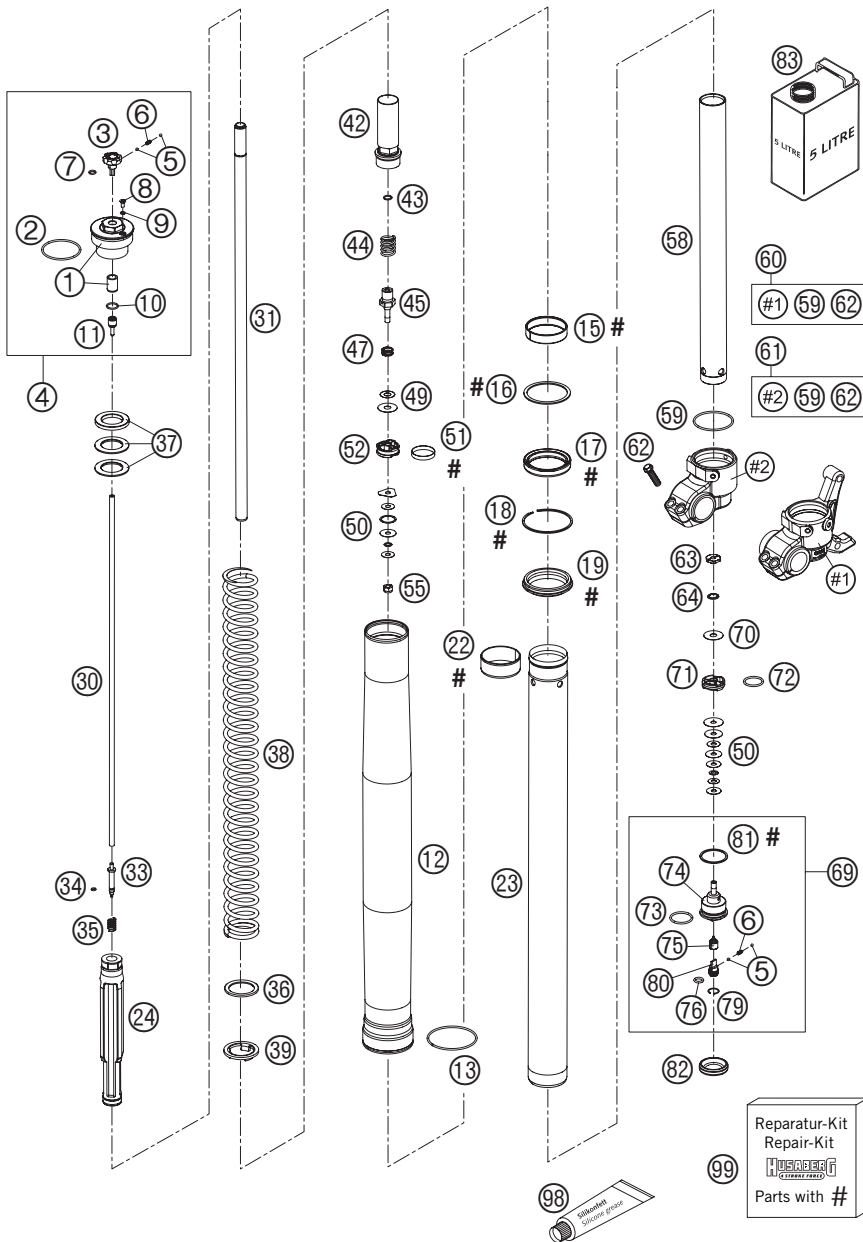

FIG	TEILNR/PARTNR	BEZEICHNUNG	DESCRIPTION	QTY
1	4860.0020S1	VERSCHLUSSKAPPE M51X1,5 KPL.	SCREW CAP M51X1,5 CPL.	2
2	4681.0340	O-RING NBR 45X2	O-RING NBR 45X2	2
3	4860.0018	EINSTELKNOPF ZUGSTUFE	KNOB REBOUNG ADJUSTER	2
4	4860.0020S1	VERSCHLUSSKAPPE M51X1,5 KPL.	SCREW CAP M51X1,5 CPL.	2
5	4054.0603	STAHLKUGEL D=3MM	STEEL BALL D=3MM	8
6	4860.0028	FEDER D=2,9 L=7,9	SPRING D=2,9 L=7,9	4
7	4860.0044	O-RING NBR 6X1,5	O-RING NBR 6X1,5	2
8	4860.0058	ENTLÜFTUNGSSCHRAUBE M4X6	VENT SCREW M4X6	2
9	4860.0009	O-RING NBR 3,7X1,6	O-RING NBR 3,7X1,6	2
10	4860.0043	O-RING NBR 12X1,5	O-RING NBR 12X1,5	2
11	4860.0019	HALTER F. EINSTELLROHR D=4MM	HOLDER F. ADJUSTMENT TUBE D=4MM	2
12*	4860.0381E	AUSSENROHR L=577 D=54/60MM	OUTER TUBE L=577 D=54/60MM	2
13	4860.0016	FÜHRUNGSRING D=58MM	GUIDING RING D=58MM	2
15*	4860.0429	FÜHRUNGSBUCHSE D48XD52X12DDL02	DU-BUSH D48XD52X12DDL02	2
16	4860.0013	TRÄGERRING 50 X 57,6 X 1,5	SUPPORT RING 50 X 57,6 X 1,5	2
17	4860.0399	ÖLDICHRING 48X57,8X9,5	OIL SEAL RING 48X57,8X9,5	2
18	4860.0070	SICHERUNGSRING SB58	LOCK WASHER SB58	2
19	4860.0400	STAUBKAPPE D=48 58,4X11,8	DUST STRIPPER D=48 58,4X11,8	2
22*	4860.0428	FÜHRUNGSBUCHSE D47XD49X20DDL02	DU-BUSH D47XD49X20DDL02	2
23*	4860.0437	GABELHOLM D=48 L=595	INNER TUBE D=48 L=595	2
24*	4860.0380S1	HYDR.STOP L=200MM D=31,9 KPL.	HYDR.STOP L=200MM D=31,9 CPL.	2
30	4860.0014	EINSTELLROHR L=512MM	ADJUSTMENT TUBE L=512MM	2
31	4860.0408	KOLBENSTANGE D=14 L=546 M11X1	PISTON ROD D=14 L=546 M11X1	2
33	4860.0189	NADEL ZUGSTUFE 2003	NEEDLE REBOUND 2003	2
34	4860.0046	O-RING NBR 3X1,5	O-RING NBR 3X1,5	2
35	4860.0033	FEDER ZUGSTUFENNADEL C=4N/MM	SPRING REBOUND NEEDLE C=4N/MM	2
36	4860.0113	UNTERLEGRING 32X42X2,5	WASHER 32X42X2,5	2
37	4860.0036	VORSPANNBÜCHSE 42X26,5X2,5	SPACER 42X26,5X2,5	2
37	4860.0037	VORSPANNBÜCHSE 42X26,5X5	SPACER 42X26,5X5	2
37	4860.0053	VORSPANNBÜCHSE 42X26,5X1,5	SPACER 42X26,5X1,5	2
38	9141.0011S	FEDER 3,6N/MM SET	SPRING 3,6N/MM SET	X
38	9141.0012S	FEDER 3,8N/MM SET D=4,9MM	SPRING 3,8N/MM SET D=4,9MM	X
38	9141.0013S	FEDER 4,0N/MM SET D=5,0MM	SPRING 4,0N/MM SET D=5,0MM	X
38	9141.0014S	FEDER 4,2N/MM SET D=5,0MM	SPRING 4,2N/MM SET D=5,0MM	X
38	9141.0015S	FEDER 4,4N/MM SET D=5,1MM	SPRING 4,4N/MM SET D=5,1MM	1

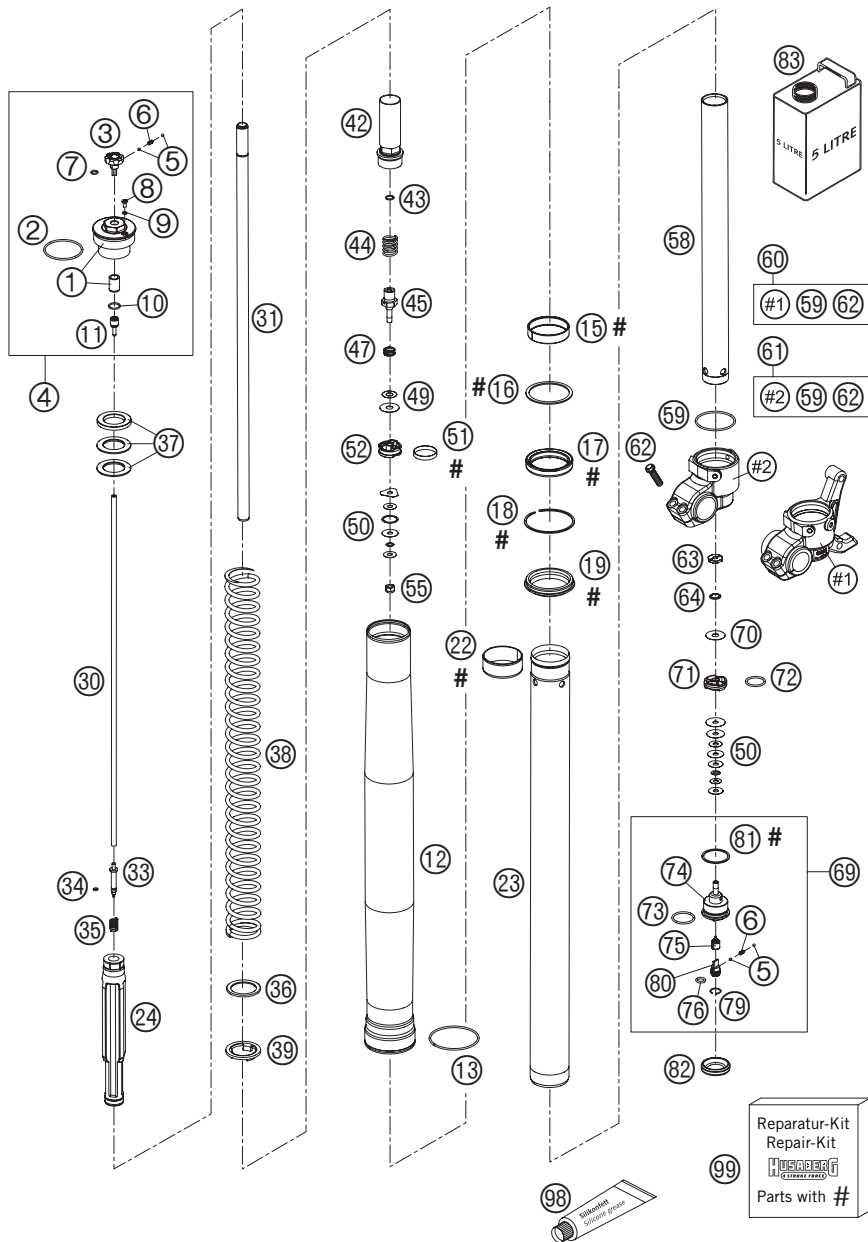

FIG	TEILNR/PARTNR	BEZEICHNUNG	DESCRIPTION	QTY
38	9141.0016S	FEDER 4,6N/MM SET	SPRING 4,6N/MM SET	X
38	9141.0017S	FEDER 4,8N/MM SET	SPRING 4,8N/MM SET	X
39	4860.0021	FEDERAUFLAGE 26,2 X 43 X 3	INTERM. RING 26,2 X 43 X 3	2
42	4860.0383S	SCHRAUBBÜCHSE M29,3X1 L=90 KPL	SCREW SLEEVE M29,3X1 L=90 CPL.	2
43	4860.0239	O-RING NBR 8X1,25	O-RING NBR 8X1,25	2
44	4860.0403	FEDER ZUGSTUFE D=15MM L=34,5MM	REBOUND SPRING D=15MM L=34,5MM	2
45	4860.0203	AUFNAHME FÜR ZUGSTUFE D=3 03	TAB REBOUND D=3 03	2
47	3548.0377	FEDER VENTIL D=0,5	SPRING CHECK VALVE D=0,5	2
49	4357.0120	SCHEIBE 8X18X0,10	SHIM 8X18X0,10	2
49	4860.0062	KONTROLLVENTIL 8X24X0,1	CHECK VALVE 8X24X0,1	8
49	4860.0215	KONTROLLVENTIL 8X20X0,1	CHECK VALVE 8X20X0,1	2
49	4860.0216	KONTROLLVENTIL 8X22X0,1	CHECK VALVE 8X22X0,1	2
50	4860.0063	SCHEIBE 6X24X0,1	SHIM 6X24X0,1	X
50	4860.0064	SCHEIBE 6X22X0,1	SHIM 6X22X0,1	X
50	4860.0065	SCHEIBE 6X20X0,1	SHIM 6X20X0,1	X
50	4860.0116	SCHEIBE 6X24X0,1 DELTA	SHIM 6X24X0,1 DELTA	X
50*	4054.0449	SCHEIBE 6X9X0,3	SHIM 6X9X0,3	X
50	4054.0401	SCHEIBE 6X14X0,1	SHIM 6X14X0,1	X
50	4054.0402	SCHEIBE 6X16X0,1	SHIM 6X16X0,1	X
50	4054.0403	SCHEIBE 6X18X0,1	SHIM 6X18X0,1	X
50	4054.0414	SCHEIBE 6X16X0,25	SHIM 6X16X0,25	X
50	4054.0415	SCHEIBE 6X18X0,25	SHIM 6X18X0,25	X
50	4054.0450	SCHEIBE 6X9,5X0,3	SHIM 6X9,5X0,3	X
51	4860.0060	KOLBENRING 5X1X84	PISTON RING 5X1X84	2
52	4860.0042	KOLBEN ZUGSTUFE D=27,7	PISTON REBOUND D=27,7	2
55	4054.0486	MUTTER M6X0,5 ZUGSTUFE	NUT M6X0,5 REBOUND	2
58	4860.0140	ROHR 29,3X1X385 ALU	TUBE 29,3X1X385 ALU	2
59	4860.0048	O-RING NBR 46 X 2	O-RING NBR 46 X 2	2
60	4860.0237S	GABELFAUST LI. KPL. USD48 04	AXLE CLAMP L/S CPL. USD48 04	1
61	4860.0238S	GABELFAUST RE. KPL. USD48 04	AXLE CLAMP R/S CPL. USD48 04	1
62	0015 080253	SK.BUNDSCHRAUBE M 8X25 SW=10	HH COLLAR SCREW M 8X25 WS=10	4
63	4860.0163	MUTTER VENTIL M6X0,5 D=2	CHECK VALVE NUT M6X0,5 D=2	2
64*	4860.0202	FEDER VENTIL D=0,7	SPRING CHECK VALVE D=0,7	2
69	4860.0152S1	AUFNAHME FÜR DRUCKSTUFE KPL.03	TAP COMPRESSION CPL. 03	2
70	4860.0061	KONTROLLVENTIL 8X24X0,4	CHECK VALVE 8X24X0,4	2

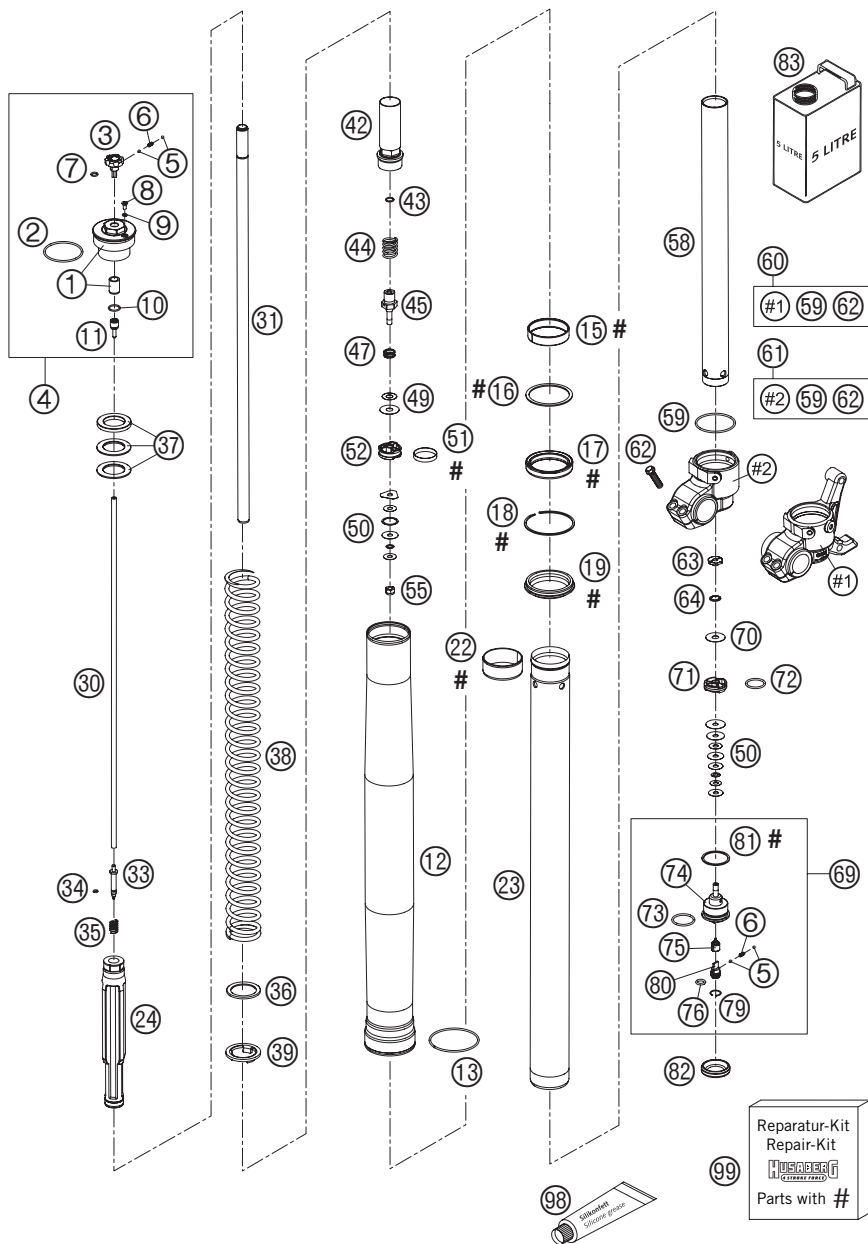

FIG	TEILNR/PARTNR	BEZEICHNUNG	DESCRIPTION	QTY
71	4860.0047	KOLBEN DRUCKSTUFE D=27,9	PISTON COMPRESSION D=27,9	2
72	4681.1499	O-RING NBR 21X2	O-RING NBR 21X2	2
73	3548.0320	O-RING NBR 24X2	O-RING NBR 24X2	2
74	4860.0152	AUFNAHME FÜR DRUCKSTUFE	TAP COMPRESSION	2
75	4860.0190	NADEL DRUCKSTUFE 2003	NEEDLE COMPRESSION 2003	2
76	4860.0049	O-RING NBR 8X2	O-RING NBR 8X2	2
79	4860.0051	SICHERUNGSRING RB12	LOCK WASHER RB12	2
80	4860.0034	EINSTELLSCHRAUBE DRUCKSTUFE	COMPRESSION ADJ. SCREW	2
81	4860.0004	CU-SCHEIBE 29,5X33,5X1	COPPER WASHER 29,5X33,5X1	2
82	4860.0141	GUMMIKAPPE D=35MM	RUBBER CAP D=35MM	2
83	4860.0401S1	GABELÖL SAE 5 2005	FORK OIL SAE 5 2005	1
98	T511.	SILIKONFETT F. STAUBMANSCHETTE	SILICONE GREASE F. DUST STRI	1
99*	R140.13	REPARATURSATZ	REPAIR-KIT GASKET 4860 MXMA 06	1

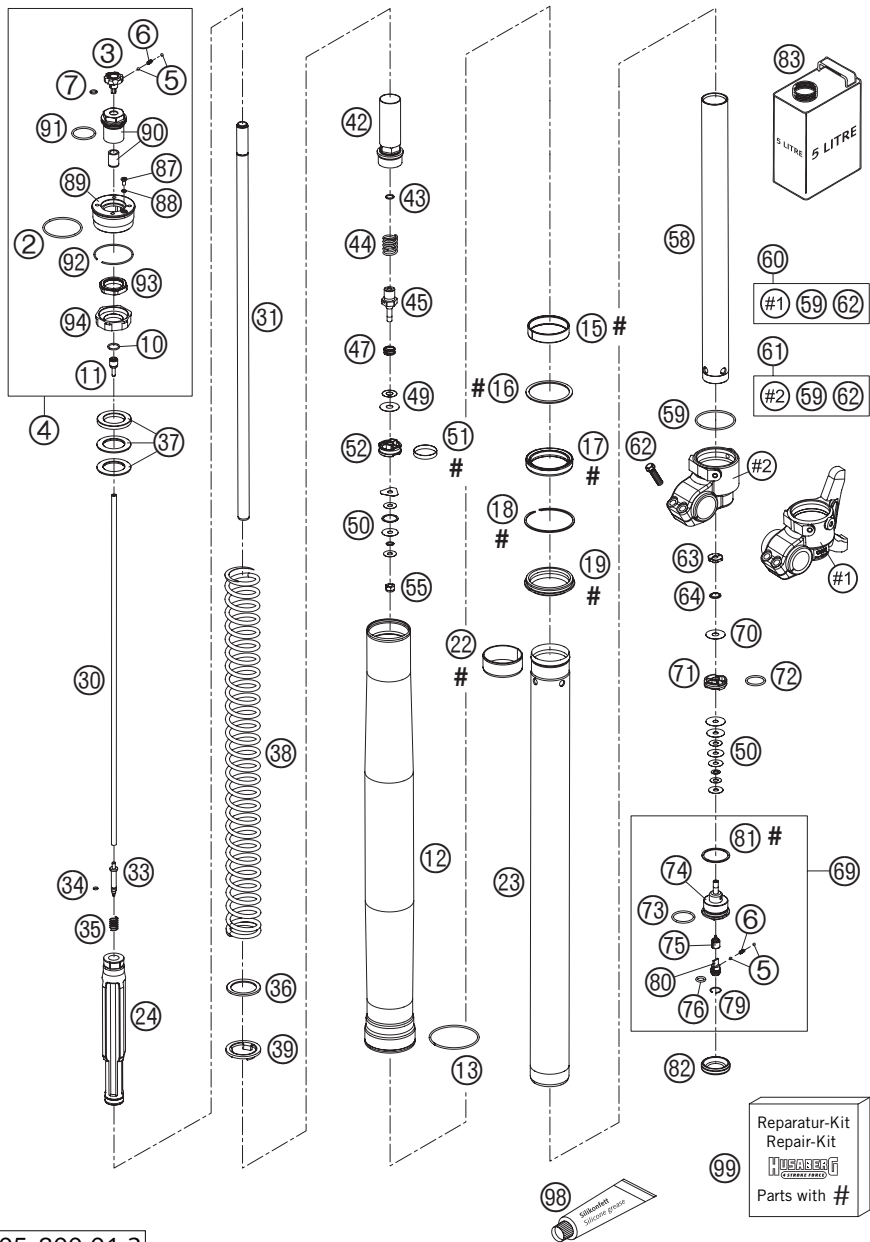
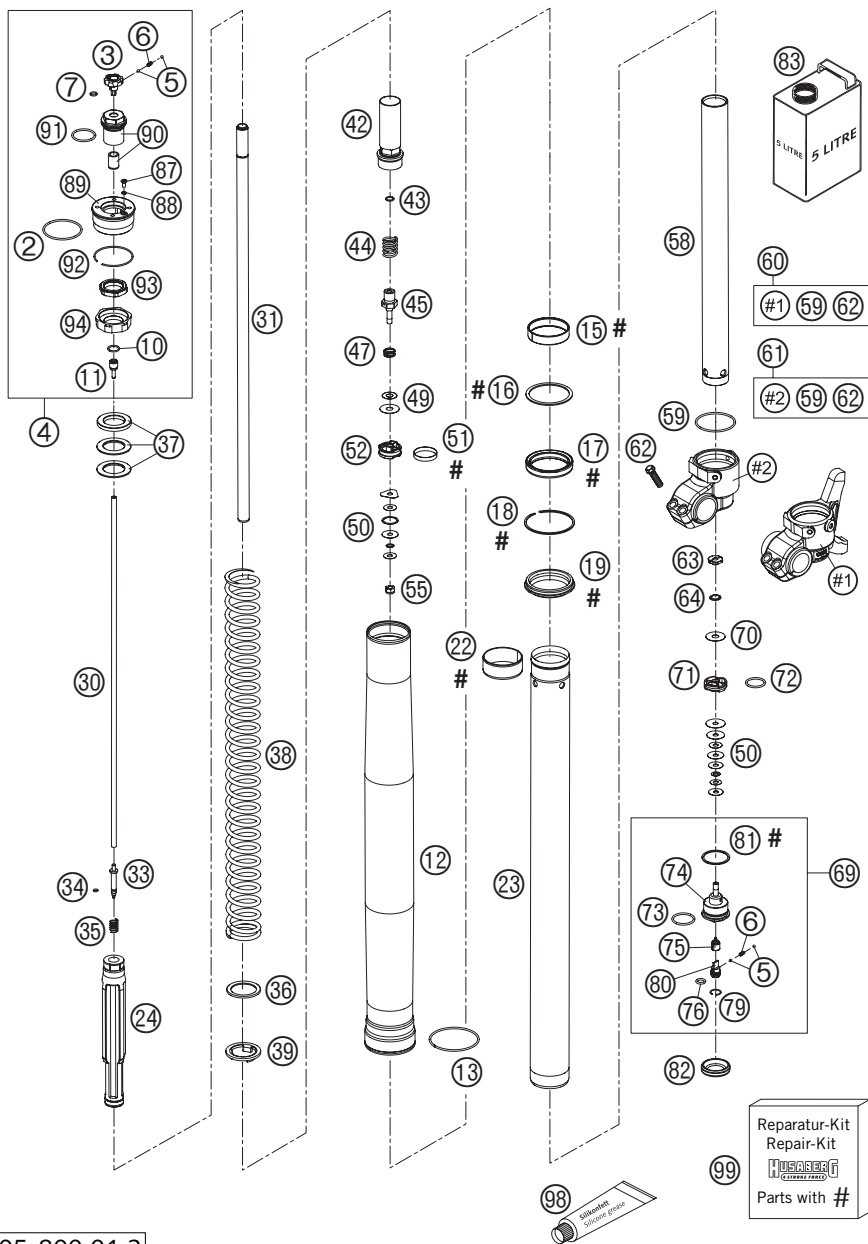

FIG	TEILNR/PARTNR	BEZEICHNUNG	DESCRIPTION	QTY
2	4681.0340	O-RING NBR 45X2	O-RING NBR 45X2	2
3	4860.0018	EINSTELKNOPF ZUGSTUFE	KNOB REBOUNG ADJUSTER	2
4	4860.0075S	PRE-LOAD ADJUSTER KPL.(1 STK.)	PRE-LOAD ADJUSTER CPL.(1 PC.)	2
5	4054.0603	STAHLKUGEL D=3MM	STEEL BALL D=3MM	8
6	4860.0028	FEDER D=2,9 L=7,9	SPRING D=2,9 L=7,9	4
7	4860.0044	O-RING NBR 6X1,5	O-RING NBR 6X1,5	2
10	4860.0043	O-RING NBR 12X1,5	O-RING NBR 12X1,5	2
11	4860.0019	HALTER F. EINSTELLROHR D=4MM	HOLDER F.ADJUSTMENT TUBE D=4MM	2
12*	4860.0381E	AUSSENROHR L=577 D=54/60MM	OUTER TUBE L=577 D=54/60MM	2
13	4860.0016	FÜHRUNGSRING D=58MM	GUIDING RING D=58MM	2
15*	4860.0429	FÜHRUNGSBUCHSE D48XD52X12DDL02	DU-BUSH D48XD52X12DDL02	2
16	4860.0013	TRÄGERRING 50 X 57,6 X 1,5	SUPPORT RING 50 X 57,6 X 1,5	2
17	4860.0399	ÖLDICHTRING 48X57,8X9,5	OIL SEAL RING 48X57,8X9,5	2
18	4860.0070	SICHERUNGSRING SB58	LOCK WASHER SB58	2
19	4860.0400	STAUBKAPPE D=48 58,4X11,8	DUST STRIPPER D=48 58,4X11,8	2
22*	4860.0428	FÜHRUNGSBUCHSE D47XD49X20DDL02	DU-BUSH D47XD49X20DDL02	2
23*	4860.0437	GABELHOLM D=48 L=595	INNER TUBE D=48 L=595	2
24*	4860.0380S1	HYDR.STOP L=200MM D=31,9 KPL.	HYDR.STOP L=200MM D=31,9 CPL.	2
30	4860.0094	EINSTELLROHR L=492MM	ADJUSTMENT TUBE L=492MM	2
31	4860.0412	KOLBENSTANGE 14X11X1 L=526	PISTON ROD 14X11X1 L=526	2
33	4860.0189	NADEL ZUGSTUFE 2003	NEEDLE REBOUND 2003	2
34	4860.0046	O-RING NBR 3X1,5	O-RING NBR 3X1,5	2
35	4860.0033	FEDER ZUGSTUFENNADEL C=4N/MM	SPRING REBOUND NEEDLE C=4N/MM	2
36	4860.0113	UNTERLEGRING 32X42X2,5	WASHER 32X42X2,5	2
37	4860.0036	VORSPANNBÜCHSE 42X26,5X2,5	SPACER 42X26,5X2,5	2
37	4860.0037	VORSPANNBÜCHSE 42X26,5X5	SPACER 42X26,5X5	2
37	4860.0053	VORSPANNBÜCHSE 42X26,5X1,5	SPACER 42X26,5X1,5	2
38	9141.0020S	FEDER 4,8N/MM SET D=5,25MM	SPRING 4,8N/MM SET D=5,25 MM	1
38	9141.0019S	FEDER 4,6N/MM SET D=5,1MM	SPRING 4,6N/MM SET D=5,1MM	X
39	4860.0021	FEDERAUFLAGE 26,2 X 43 X 3	INTERM. RING 26,2 X 43 X 3	2
42*	4860.0200S1	SCHRAUBBÜCHSE M29,3X1 L=65 KPL	SCREW SLEEVE M29,3X1 L=65 CPL.	2
43*	4860.0239	O-RING NBR 8X1,25	O-RING NBR 8X1,25	2
44	4860.0403	FEDER ZUGSTUFE D=15MM L=34,5MM	REBOUND SPRING D=15MM L=34,5MM	2
45	4860.0203	AUFNAHME FÜR ZUGSTUFE D=3 03	TAB REBOUND D=3 03	2
47	3548.0377	FEDER VENTIL D=0,5	SPRING CHECK VALVE D=0,5	2



05-800.01.3

FIG	TEILNR/PARTNR	BEZEICHNUNG	DESCRIPTION	QTY
49	4860.0062	KONTROLLVENTIL 8X24X0,1	CHECK VALVE 8X24X0,1	X
49	4860.0346	SCHEIBE 8X11X0,2	SHIM 8X11X0,2	X
49	4860.0352	KONTROLLVENTIL 8X11X0,4	CHECK VALVE 8X11X0,4	X
49	4860.0068	KONTROLLVENTIL 8X18X0,1	CHECK VALVE 8X18X0,1	X
49	4860.0215	KONTROLLVENTIL 8X20X0,1	CHECK VALVE 8X20X0,1	X
49	4860.0216	KONTROLLVENTIL 8X22X0,1	CHECK VALVE 8X22X0,1	X
50	4860.0063	SCHEIBE 6X24X0,1	SHIM 6X24X0,1	X
50	4860.0064	SCHEIBE 6X22X0,1	SHIM 6X22X0,1	X
50	4860.0065	SCHEIBE 6X20X0,1	SHIM 6X20X0,1	X
50	4860.0069	SCHEIBE 6X20X0,15	SHIM 6X20X0,15	X
50	4860.0116	SCHEIBE 6X24X0,1 DELTA	SHIM 6X24X0,1 DELTA	X
50	4860.0212	DRUCKRING 20X16,25X0,20	PRESSURE-RING 20X16,25X0,20	X
50	4054.0402	SCHEIBE 6X16X0,1	SHIM 6X16X0,1	X
50	4054.0403	SCHEIBE 6X18X0,1	SHIM 6X18X0,1	X
50	4054.0405	SCHEIBE 6X14X0,15	SHIM 6X14X0,15	X
50	4054.0406	SCHEIBE 6X16X0,15	SHIM 6X16X0,15	X
50	4054.0414	SCHEIBE 6X16X0,25	SHIM 6X16X0,25	X
50	4054.0415	SCHEIBE 6X18X0,25	SHIM 6X18X0,25	X
50	4054.0447	SCHEIBE 6X10X0,3	SHIM 6X10X0,3	X
50	4054.1417	SCHEIBE 6X11X0,25	SHIM 6X11X0,25	X
51	4860.0060	KOLBENRING 5X1X84	PISTON RING 5X1X84	2
52	4860.0042	KOLBEN ZUGSTUFE D=27,7	PISTON REBOUND D=27,7	2
55	4054.0486	MUTTER M6X0,5 ZUGSTUFE	NUT M6X0,5 REBOUND	2
58	4860.0140	ROHR 29,3X1X385 ALU	TUBE 29,3X1X385 ALU	2
59	4860.0048	O-RING NBR 46 X 2	O-RING NBR 46 X 2	2
60	4860.0402S	GABELFAUST LI. KPL. USD48 05	AXLE CLAMP L/S CPL. USD48 05	1
61	4860.0238S	GABELFAUST RE. KPL. USD48 04	AXLE CLAMP R/S CPL. USD48 04	1
62	0015 080253	SK.BUNDSCHRAUBE M 8X25 SW=10	HH COLLAR SCREW M 8X25 WS=10	4
63	4860.0163	MUTTER VENTIL M6X0,5 D=2	CHECK VALVE NUT M6X0,5 D=2	2
64	4860.0202	FEDER VENTIL D=0,7	SPRING CHECK VALVE D=0,7	2
69	4860.0152S1	AUFNAHME FÜR DRUCKSTUFE KPL.03	TAP COMPRESSION CPL. 03	2
70	4860.0061	KONTROLLVENTIL 8X24X0,4	CHECK VALVE 8X24X0,4	2
71	4860.0047	KOLBEN DRUCKSTUFE D=27,9	PISTON COMPRESSION D=27,9	2
72	4681.1499	O-RING NBR 21X2	O-RING NBR 21X2	2
73	3548.0320	O-RING NBR 24X2	O-RING NBR 24X2	2

* = NEUTEIL / NEW PART

X = NACH BEDARF / AS REQUIRED

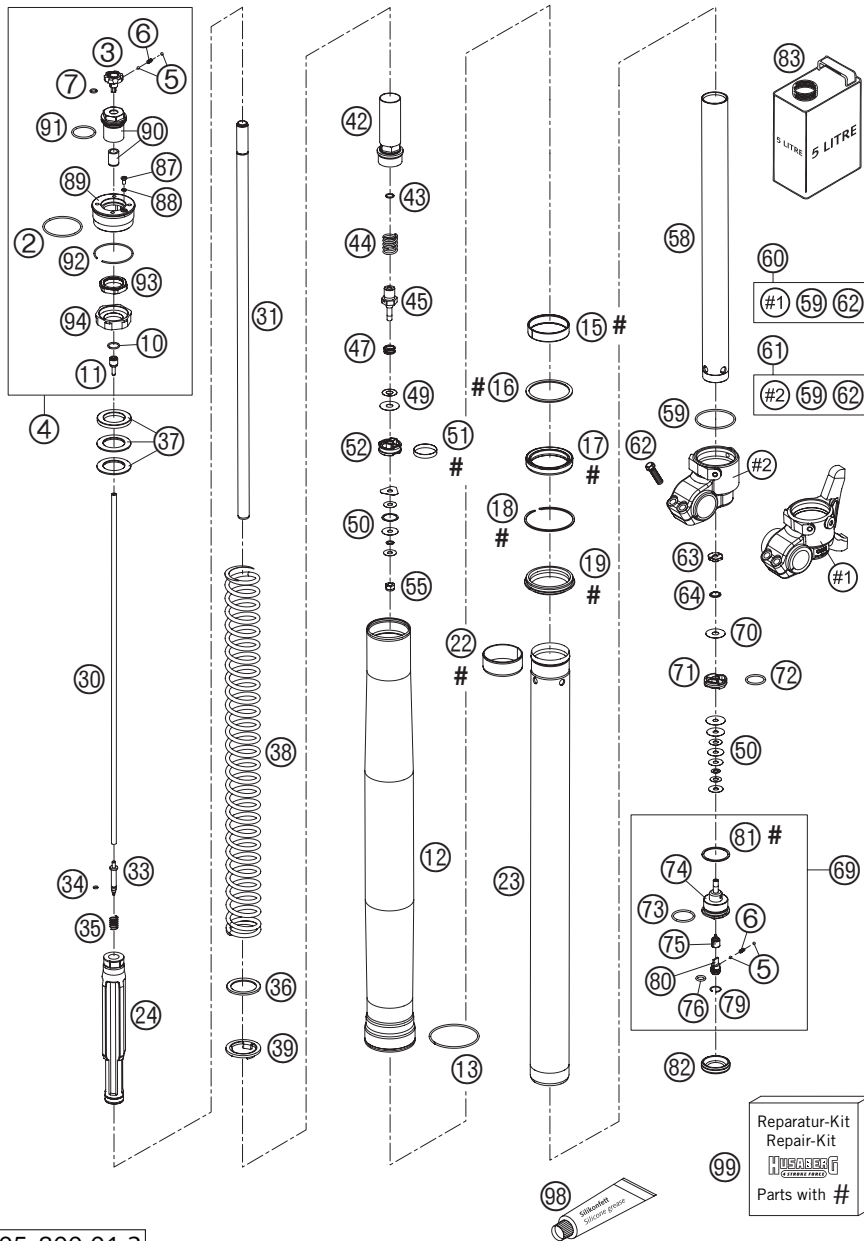

FIG	TEILNR/PARTNR	BEZEICHNUNG	DESCRIPTION	QTY
74	4860.0152	AUFNAHME FÜR DRUCKSTUFE	TAP COMPRESSION	2
75	4860.0190	NADEL DRUCKSTUFE 2003	NEEDLE COMPRESSION 2003	2
76	4860.0049	O-RING NBR 8X2	O-RING NBR 8X2	2
79	4860.0051	SICHERUNGSRING RB12	LOCK WASHER RB12	2
80	4860.0034	EINSTELLSCHRAUBE DRUCKSTUFE	COMPRESSION ADJ. SCREW	2
81	4860.0004	CU-SCHEIBE 29,5X33,5X1	COPPER WASHER 29,5X33,5X1	2
82	4860.0141	GUMMIKAPPE D=35MM	RUBBER CAP D=35MM	2
83	4860.0401S1	GABELÖL SAE 5 2005	FORK OIL SAE 5 2005	1
87	4860.0076	ENTLÜFTUNGSSCHRAUBE M4X8	VENT SCREW M4X8	2
88	4860.0046	O-RING NBR 3X1,5	O-RING NBR 3X1,5	2
89	4860.0075	SCHRAUBVERSCHLUSS M51X1,5	SCREW CAP M51X1,5	2
90	4860.0073S	ADAPTER EINSTELKNOPF + BÜCHSE	ADAPTER ADJUST. KNOB + BUSHING	2
91	4860.0077	O-RING NBR 26X2	O-RING NBR 26X2	2
92	4681.0010	SPRENGRING 49X1,5	CIRCLIP 49X1,5	2
93	4860.0072	SICHERUNGSMUTTER	LOCKNUT	2
94	4860.0071	FEDERHALTERING	SUPPORT RING FOR SPRING	2
98	T511.	SILIKONFETT F. STAUBMANSCHETTE	SILICONE GREASE F. DUST STRI	1
99*	R140.13	REPARATURSATZ	REPAIR-KIT GASKET 4860 MXMA 06	1

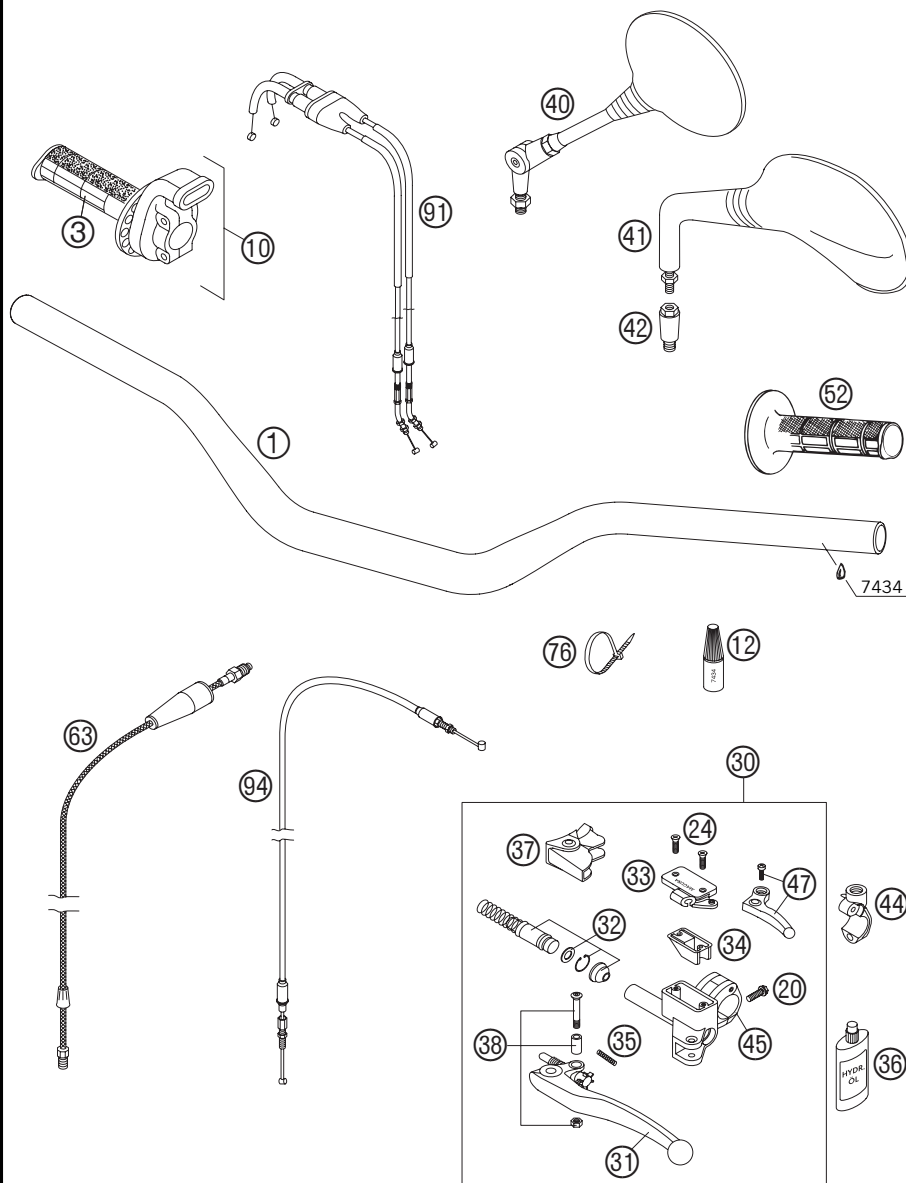

FIG	TEILNR/PARTNR	BEZEICHNUNG	DESCRIPTION	QTY
1	590.02.001.000	LENKER MAGURA SX 28MM 00	HANDLEBAR 28MM HIGH 2000	1
3	800.02.003.000	DREHGRIFÜBERZUG DOMINO HUS.05	TWIST GRIP COVER DOMINO HUS.05	1
10	800.02.010.000	GASDREHGRIF KPL. HUSABERG 05	THROTTLE GRIP CPL. HUSABERG 05	1
12	6 899 792	KLEBER CYANACRYLAT 7434	GRIP GLUE	1
20	0015 060203	SK.BUNDSCHRAUBE M 6X20 SW=8	HH COLLAR SCREW M 6X20 WS=8	1
24	0965 040123	SENKSCHRAUBE DIN0965-M 4X12	FLAT HEAD SCREW DIN0965-M 4X12	2
30	590.02.030.100	GEBERZYLINDER KPL. RACING 03	MASTER CYLINDER CPL. RACING 03	1
31	546.02.031.000	KUPPLUNGHEBEL KURZ KPL. 2003	CLUTCH LEVER SHORT CPL. 2003	X
31	590.02.031.000	KUPPLUNGHEBEL LANG KPL. 2003	CLUTCH LEVER LONG CPL. 2003	1
32	590.02.032.000	REP.SÄTZ KOLBEN 9,5MM RAC.2000	REP.KIT PISTON 9,5MM RAC. 2000	1
33	590.02.033.000	DECKEL HYD.KUPPL. RACING 2000	COVER HYD.CLUTCH RACING 2000	1
34	503.02.034.000	GUMMIBALG FÜR RESERVOIR '98	RUBBER FOR RESERVOIR '98	1
35	590.02.035.000	FEDER FÜR KUPPLUNGHEBEL 03	SPRING FOR CLUTCH LEVER 03	1
36	503.02.036.200	ÖL FÜR HYD.KUPPLUNG 75ML	OIL FOR HYD. CLUTCH 75ML	1
37	503.02.037.000	SCHUTZKAPPE FÜR HEBELGELENK'98	PROTECT.CAP FOR LEVER PERCH'98	1
38	503.02.038.000	HEBELSCHRAUBE KPL. 125-200 '98	LEVER SCREW CPL. 125-200 '98	1
40	583.12.040.200	RÜCKSPIEGEL KLAPPBAR 02 FS	REAR MIRROR L/S FOLDABLE SC 02 FS	2
41	584.12.040.000	SPIEGEL LINKS 98 FE	MIRROR L/S 98 FE	1
41	584.12.041.000	SPIEGEL RECHTS 98 FE	MIRROR R/S 98 FE	1
42	584.12.040.050	ADAPTER FÜR SPIEGEL LC4 '98	SUPPORT FOR MIRROR LC4 '98	2
44	590.02.044.000	KLEMMSCH.SPIEGEL M.SPANNSTIFT	CLAMP MIRROR WITH PIN	1
45	503.02.030.150	KLEMMSCHELLE M.SPANNSTIFT 2000	CLAMP WITH PIN 2000	1
47	590.02.047.000	HEBEL KPL. RACING 2000	DECO.LEVER CPL. RACING 2000	1
52	800.02.052.000	FESTGRIF DOMINO HUSABERG 05	FIXED GRIP DOMINO HUSABERG 05	1
63	800.32.063.000	KUPPLUNGSEITUNG HUSABERG 2004	CLUTCH PIPE HUSABERG 2004	1
76	440.11.076.100	KABELBAND 100/2,5MM SCHWARZ	CABLE TIE 100/2,5MM BLACK	X
76	440.11.076.200	KABELBAND 200/3,6MM SCHWARZ	CABLE TIE 200/3,6MM BLACK	X
91	590.02.091.300	GASSEILE "AUF/ZU" KEIHIN 02	THR.CABLE"OPEN-CLOSE"KEIHIN 02	1
94	590.02.094.000	HANDDEKOSEIL 2000	DECOMPR. CABLE RACING 2000	1

FIG	TEILNR/PARTNR	BEZEICHNUNG	DESCRIPTION	QTY
1*	548.13.001.300	HANDBREMSZYLINDER KPL. EXC 06	HAND BRAKE CYLINDER CPL. EXC 06	1
2*	548.13.002.000	HANDBREMSHEBEL + FEDER 2005	HAND BRAKE LEVER + SPRING 2005	1
3	503.13.003.000	HANDBREMSZYL. DECKEL KPL. NATUR	HANDBRAKE CYL. COVER CPL. NATURE	1
4	503.13.004.000	SCHUTZKAPPE HANDBREMSZYLINDER	PROTECTION CAP HAND BRAKE CYL.	1
5	503.13.005.000	SCHELLE KPL. NATUR	CLAMP CPL. NATURE	1
6	503.13.006.100	HEBELSCHRAUBE KPL. 2001	LEVER SCREW CPL. 2001	1
7	503.13.007.100	STELLSCHRAUBE KPL. EXC 2000	ADJUSTING SCREW CPL. EXC 2000	1
8*	548.13.008.200	REP.SATZ KOLBEN D=10MM 2006	REP.SET PISTON D=10MM 2006	1
11	590.13.011.000	BREMSSCHL. VO. 1300MM 2000	BRAKEHO. FRONT 1300MM 2000	1
25	502.13.025.000	HOHLSCHRAUBE M10X1X19	HOLLOW SCREW M10X1X19	1
26	420.13.226.000	CU-DICHRING DIN7603-10X16X1	CU-SEAL RING DIN7603-10X16X1	2
30	0015 060253	SK.BUNDSCHRAUBE M 6X25 SW=8	HH COLLAR SCREW M 6X25 WS=8	2
40	580.12.040.150	KLEMMSCHELLE FÜR SPIEGEL '94	CLAMP FOR MIRROR '94	1
50	306054	BREMFLÜSSIGKEIT DOT 5.1	BRAKE FLUID DOT 5.1	1

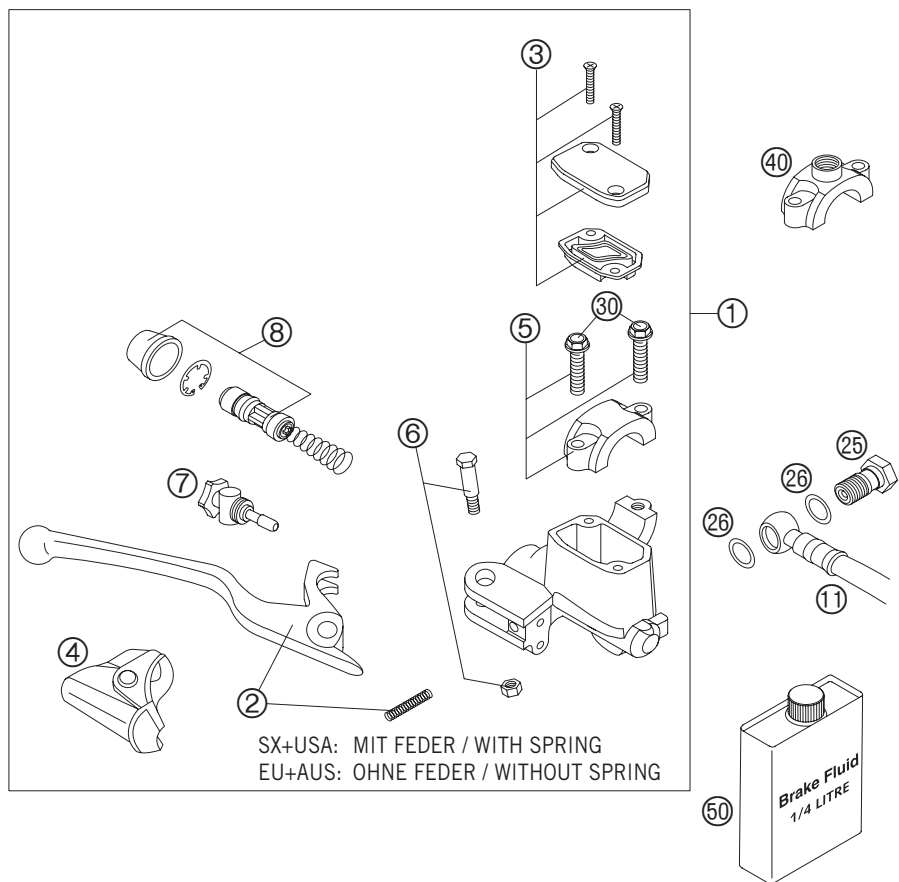
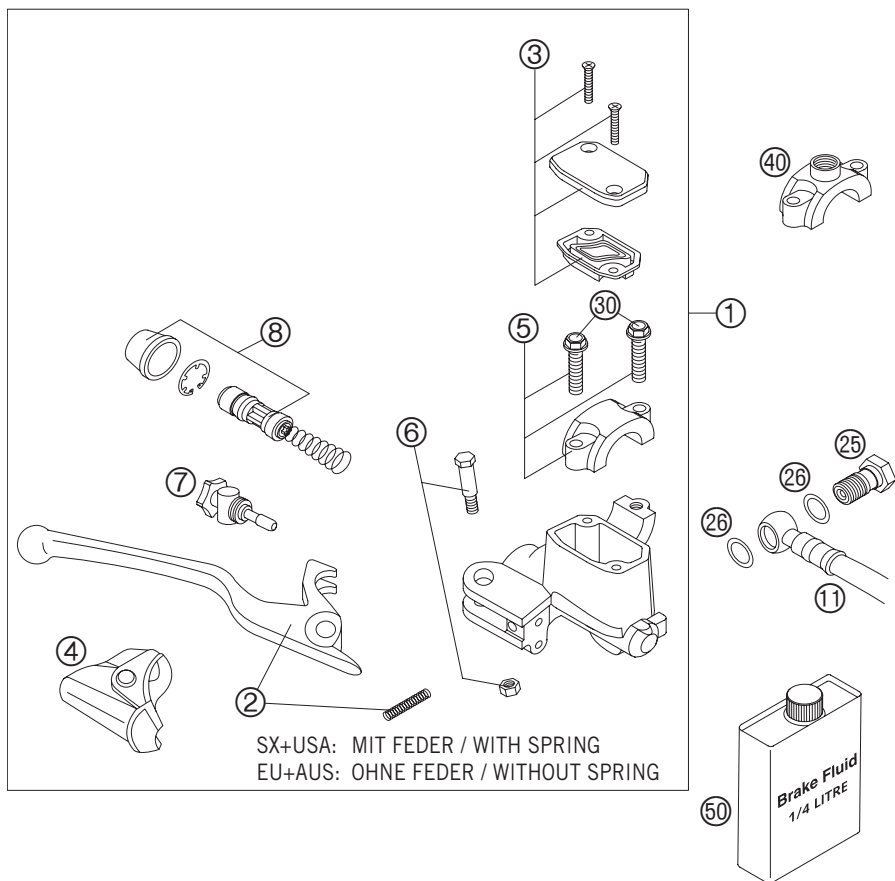

FIG	TEILNR/PARTNR	BEZEICHNUNG	DESCRIPTION	QTY
1	503.13.001.100	HANDBREMSZYL. NATUR KLEIN 2001	HANDBRAKE CYL. NAT. SMALL 2001	1
2	503.13.002.100	HANDBREMSHEBEL KURZ 2001	HANDBRAKE LEVER SHORT 2001	1
3	503.13.003.000	HANDBREMSZYL.DECKEL KPL. NATUR	HANDBRAKE CYL.COVER CPL.NATURE	1
4	503.13.004.000	SCHUTZKAPPE HANDBREMSZYLINDER	PROTECTION CAP HAND BRAKE CYL.	1
5	503.13.005.000	SCHELLE KPL. NATUR	CLAMP CPL. NATURE	1
6	503.13.006.100	HEBELSCHRAUBE KPL. 2001	LEVER SCREW CPL. 2001	1
7	503.13.007.100	STELLSCHRAUBE KPL. EXC 2000	ADJUSTING SCREW CPL. EXC 2000	1
8	503.13.008.300	REP.SATZ KOLBEN D=11 EXC 2001	REP.SET PISTON D=11 EXC 2001	1
11	590.13.011.000	BREMSSCHL. VO. 1300MM 2000	BRAKEHO. FRONT 1300MM 2000	1
25	502.13.025.000	HOHLSCHRAUBE M10X1X19	HOLLOW SCREW M10X1X19	1
26	420.13.226.000	CU-DICHRING DIN7603-10X16X1	CU-SEAL RING DIN7603-10X16X1	2
30	0015 060253	SK.BUNDSCHRAUBE M 6X25 SW=8	HH COLLAR SCREW M 6X25 WS=8	2
40	580.12.040.150	KLEMMSCHELLE FÜR SPIEGEL '94	CLAMP FOR MIRROR '94	1
50	306054	BREMFLÜSSIGKEIT DOT 5.1	BRAKE FLUID DOT 5.1	1



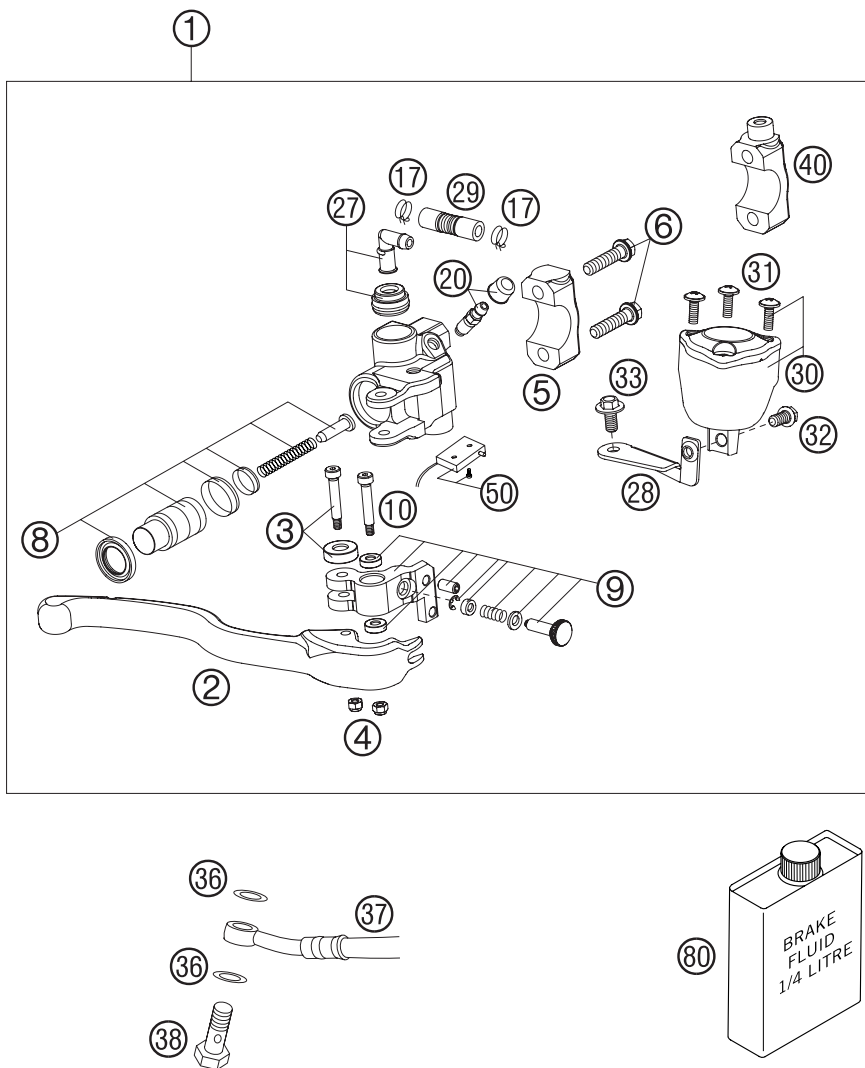

FIG	TEILNR/PARTNR	BEZEICHNUNG	DESCRIPTION	QTY
1	586.13.001.044	HANDBREMSZYLINDER KPL.	HANDBRAKECYLINDER CPL.	05 1
2	586.13.002.000	HANDBREMSHEBEL	HANDBRAKE LEVER	05 1
3	586.13.002.150	HEBELSCHRAUBE	LEVER SCREW	05 1
4	0985 040003	SS.MUTTER DIN0985-M 4, A2-NIRO	SELF LOCKING NUT DIN0985-M 4	2
5	586.13.005.150	KLEMMSCHELLE	CLAMP	05 1
6	0015 060253	SK.BUNDSCHRAUBE M 6X25 SW=8	HH COLLAR SCREW M 6X25 WS=8	2
8	586.13.008.000	REP. SATZ KOLBEN	REP. SET PISTON	05 1
9	586.13.002.050	WIPPE KPL.	ROCKER CPL.	05 1
10	586.13.006.000	LAGERBOLZEN	BEARING BOLT	05 1
17	590.07.017.000	YDNAC KLAMMER 10096F (9,6MM)	CLAMP YDNAC 10096F (9,6MM)	2
20	586.13.020.000	ENTLÜFTUNGSSCHRAUBE MIT KAPPE	BLEEDER SCREW WITH CAP	1
27	586.13.027.000	ANSCHLUSSROHR KPL.	CONNECTING TUBE CPL.	05 1
28	586.13.028.000	HALBLECH	RETAINING PLATE	05 1
29	586.13.029.150	SCHLAUCH FÜR RESERVOIR	HOSE FOR RESERVOIR	05 1
30	586.13.029.044	BREMSE. RESERVOIR KPL.	BRAKE FLUID RESERVOIR CPL.	05 1
31	586.13.029.050	BEFESTIGUNGSSCHR.F.RESERV.	FIXING SCREW F. RESERV.	05 3
32	0015 060123	SK.BUNDSCHRAUBE M 6X12 SW=8	HH COLLAR SCREW M 6X12 WS=8	1
33	0014 060133	SK.BUNDSCHRAUBE M 6X13 SW=8	HH COLLAR SCREW M 6X13 WS=8	1
36	0603 100141	CU-DICHTRING DIN7603-10X14X1	COPPER GASKET DIN7603-10X14X1	2
37	586.13.012.000	BREMSSCHLAUCH 1260MM FS-E	BRAKEHOSE 1260MM FS-E	05 1
37	586.13.012.100	BREMSSCHLAUCH 1175MM FS-C	BRAKEHOSE 1175MM FS-C	05 1
38	586.13.013.100	HOHLSCHRAUBE	HOLLOW SCREW	05 1
40	586.13.005.050	KLEMMSCHELLE FÜR SPIEGEL	CLAMP FOR MIRROR	05 1
50	586.11.050.000	BREMSLICHTSCHALTER KPL.	BRAKE LIGHT SWITCH CPL.	05 1
80	3060.54	BREMSSCHLAUCH 1260MM FS-E	BRAKE FLUID DOT 5.1	1

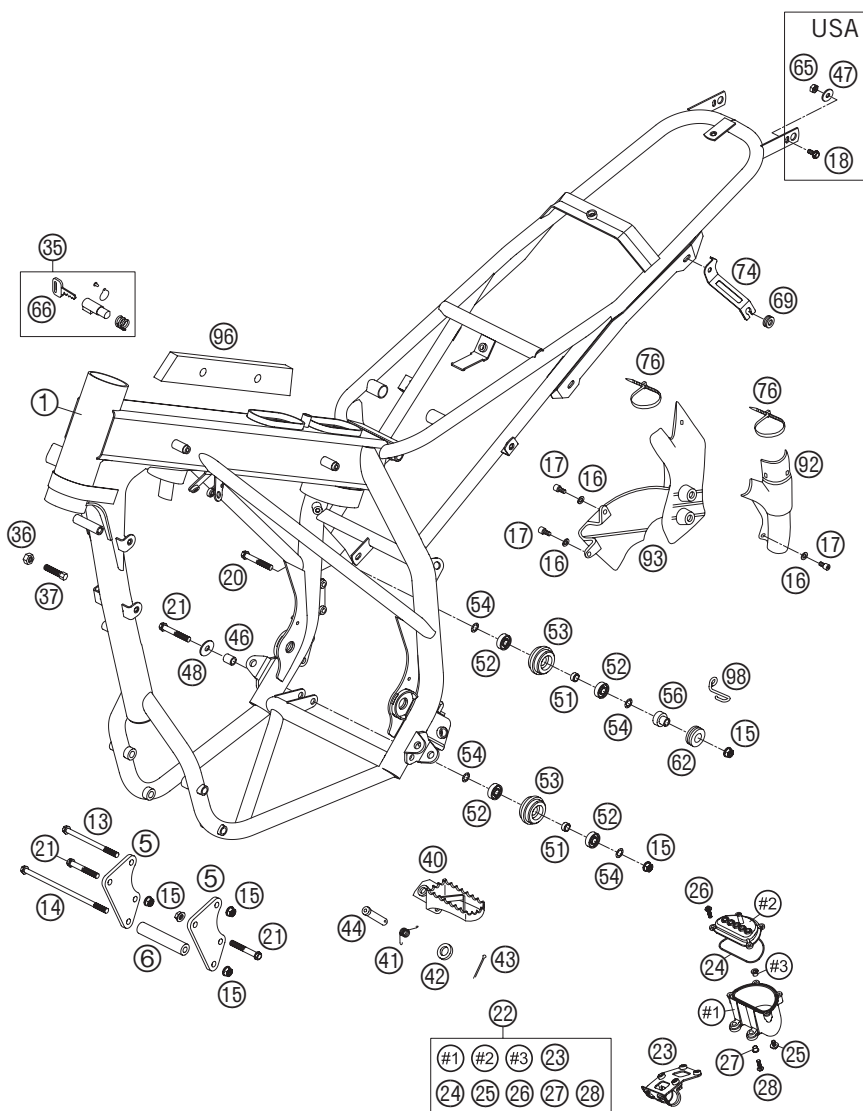

FIG	TEILNR/PARTNR	BEZEICHNUNG	DESCRIPTION	QTY
1*	800.03.001.000/30	RAHMEN FC SCHWARZ (HA04)	FRAME FC BLACK (HA04)	1
1*	800.03.001.200/30	RAHMEN FE/FS-USA SCHWARZ(HC04)	FRAME FE/FS-USA BLACK (HC04)	1
5	800.03.005.000	MOTORAUFHÄNGUNG 04	ENGINE MOUNTING 04	2
6	800.03.006.000	DISTANZ MOTORAUFHÄNG.L=87MM 04	SPACER ENGINE MOUNT. L=87MM 04	1
13	800.03.013.000	MOTORTRAGSCHRAUBE M8X110 04	ENGINE BRACKET SCREW M8X110 04	2
14	800.03.014.000	MOTORTRAGSCHRAUBE M8X180 04	ENGINE BRACKET SCREW M8X180 04	1
15	543.10.086.200	STOVER-FLANSCHMUTTER M8 10.9	SELF LOCKING NUT M8 10.9	7
16	0125 050003	UNTERLEGSCHIBE DIN0125 A 5,3	WASHER DINO125-A 5,3	3
17	0912 050103	ISK.SCHRAUBE DIN 912 M5X10	AH SCREW DIN0912-M 5X10	3
18	0015 050123	SK.BUNDSCHRAUBE M 5X12 SW=8	HH COLLAR SCREW M 5X12 WS=8	2
20	0015 080503	SK.BUNDSCHRAUBE M 8X50 SW=10	HH COLLAR SCREW M 8X50 WS=10	1
21	0015 080503	SK.BUNDSCHRAUBE M 8X50 SW=10	HH COLLAR SCREW M 8X50 WS=10	3
22	800.31.096.044	AUFFANGBEHÄLTER KPL.	INTERCEPTING TANK CPL.	1
23	800.31.096.050	HALTEBL. F. AUFFANGBEHÄLTER 05	BRACKET F.INTERCEPTING TANK 05	1
24	0770 800021	O-RING 80,00X2,00 VITON	O-RING 80,00X2,00 VITON	1
25	0014 060103	SK.BUNDSCHRAUBE M 6X10 SW=8	HH COLLAR SCREW M 6X10 WS=8	2
26	0017 060203	EJOT PT SCHRAUBE K60X20 SW=6	EJOT PT SCREW K60X20 WS=6	4
27	583.14.060.050	DISTANZBÜCHSE F.TACHOHALTERUNG	SPACER BUSH. F. SPEEDOMET.BRA.	2
28	0014 060153	SK.BUNDSCHRAUBE M 6X15 SW=8	HH COLLAR SCREW M 6X15 WS=8	2
35	800.03.035.000	STEUERKOPFSCHLOSS FE+FS EU	STEERING HEAD LOCK FE+FS EU	1
36	0934 080003	SK.MUTTER DIN 934 M8	HEXAGON NUT DIN0934-M 8	2
37	590.01.037.000	ANSCHLAGSCHRAUBE M8X26 SW=10	SPECIAL SCREW M8X26 WS=10	2
40	590.03.040.250	FUSSRASTE LINKS SILBER 02	FOOT PED L/S SILVER 02	1
40	590.03.041.250	FUSSRASTE RECHTS SILBER 02	FOOT PED R/S SILVER 02	1
41	546.03.041.000	FUSSRASTENFEDER LINKS & RECHTS	FOOTREST SPRING L/S & R/S	2
42	0125 100003	UNTERLEGSCHIBE DIN0125 A 10,5	WASHER DINO125-A10,5	2
43	0094 032253	SPLINT DIN0094-3,2X25 STAHL	PIN DIN0094-3,2X25 STEEL	2
44	548.03.044.000	BOLZEN FÜR FUSSRASTE 03	BOLT FOR FOOT PED 03	2
46	800.13.046.100	DISTANZBÜCHSE 22X8,2X16 MM 05	DISTANCE SPACER 22X8,2X16MM 05	1
47	0021 050003	SCHEIBE DIN 9021 A 5,3	WASHER DIN9021-A 5,3	2
48	0021 080003	SCHEIBE DIN 9021 A 8,4	WASHER DIN9021-A 8,4	1
51	740.03.021.000	BÜCHSE 8.2 X 12 X 6	BUSHING 8.2 X 12 X 6	2
52	0625 006087	RILLENKUGELLAGER 608 2RS C3	GROOVED BALL BEAR. 608 2RS C3	4
53	523.03.053.100	KETTENROLLE D=35MM 125-380 '99	CHAIN ROLL D=35MM 125-380 '99	2

FIG	TEILNR/PARTNR	BEZEICHNUNG	DESCRIPTION	QTY
54	360.03.014.000	SCHNORR-SICHERUNGSSCHEIBE 8MM	LOCK WASHER 8MM	4
56	800.11.056.100	DISTANZBÜCHSE 8MM 04	DISTANCE SPACER 8MM 04	1
62	410.01.052.000	KABELTÜLLE D=12MM	RUBBER SLEEVE D=12MM	1
65	0985 050003	SS.MUTTER DIN 985 M5	SELF LOCKING NUT DIN985-M 5	2
66	400.11.166.200	SCHLÜSSELROHLING 2-T./HUSABERG	KEY BLANK 2-STROKE/HUSABERG	1
69	582.14.069.051	GUMMITÜLLE 16X10,8X3 02	RUBBER GROMMET 16X10,8X3 02	1
74	800.08.014.100	BÜGEL HECKVERKLEIDUNG 2005	BRACKET FOR REAR PART 2005	1
76	440.11.076.200	KABELBAND 200/3,6MM SCHWARZ	CABLE TIE 200/3,6MM BLACK	2
92	800.03.092.000/30	RAHMENSCHUTZ LINKS SCHWARZ 04	FRAME PROTECTION L/S BLACK 04	1
93	800.03.093.000/30	RAHMENSCHUTZ RECHTS SCHWARZ 04	FRAME PROTECTION R/S BLACK 04	1
96	800.06.096.000	FILTERSCHUTZ-STREIFEN 04	TAB FOR FILTER PROTECTION 04	2
98*	800.13.094.000	BREMSSCHLAUCHFÜHRUNG	BRAKE HOSE GUIDE LOWER	1

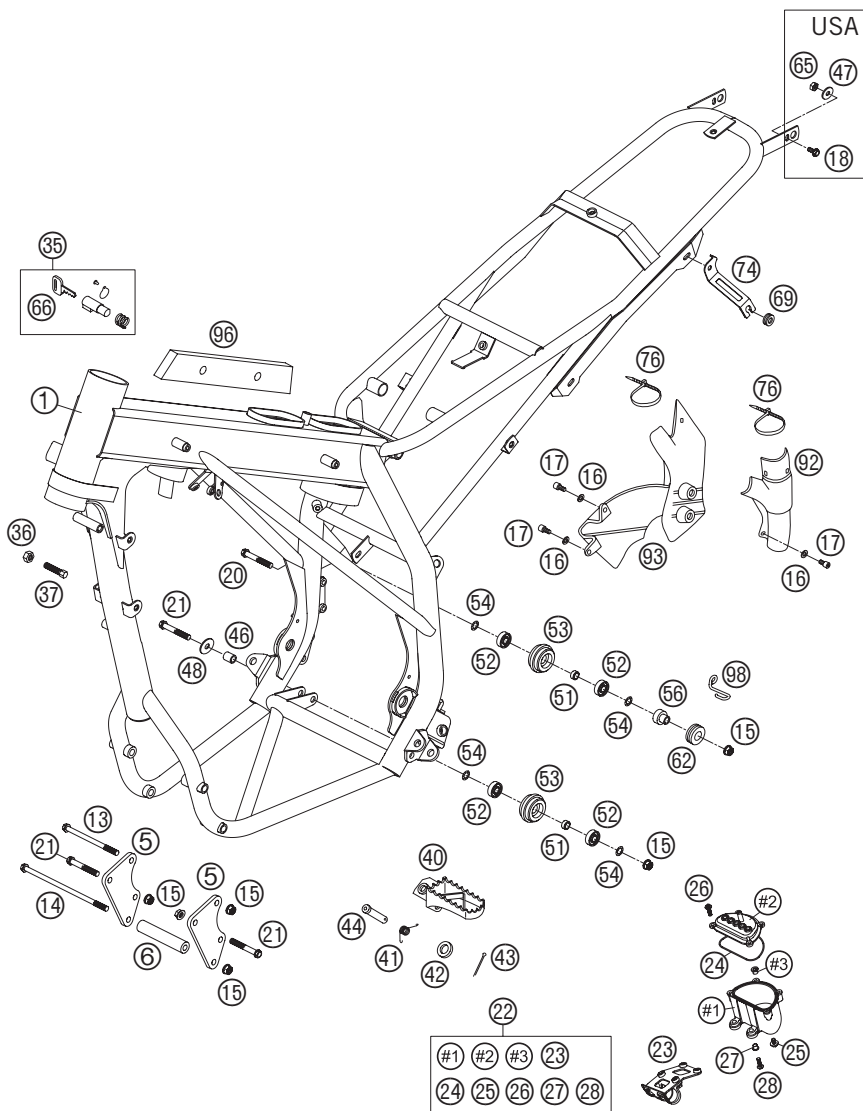

FIG	TEILNR/PARTNR	BEZEICHNUNG	DESCRIPTION	QTY
18	503.03.018.000	HALTEGUMMI L=145MM	RUBBER L=145MM	1
23*	800.03.023.100/30	SEITENSTÄNDER FE LANG 06	SIDE STAND FE LONG 06	1
23*	800.03.123.100/30	SEITENSTÄNDER FS KURZ 05	SIDE STAND FS SHORT 05	1
24	800.03.024.000	SEITENSTÄNDERFEDER INNEN 04	INNER SIDE STAND SPRING 04	1
25	800.03.024.100	SEITENSTÄNDERFEDER AUSSEN 04	OUTER SIDE STAND SPRING 04	1
27	800.03.027.000	SONDERSCHRAUBE M8X28 SW=13 04	SPECIAL SCREW M8X28 WS=13 04	1
31	800.03.031.000	FEDERBÜGEL SEITENSTÄNDER 04	SPRING CLIP SIDE STAND 04	1

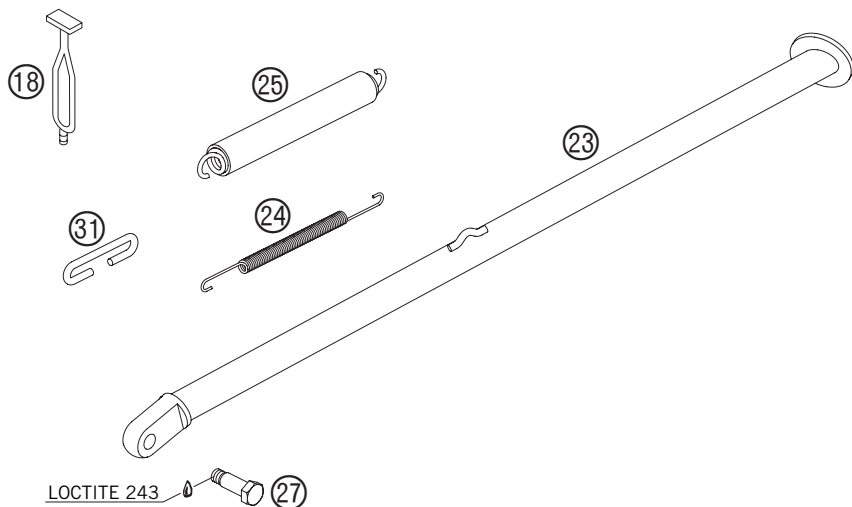
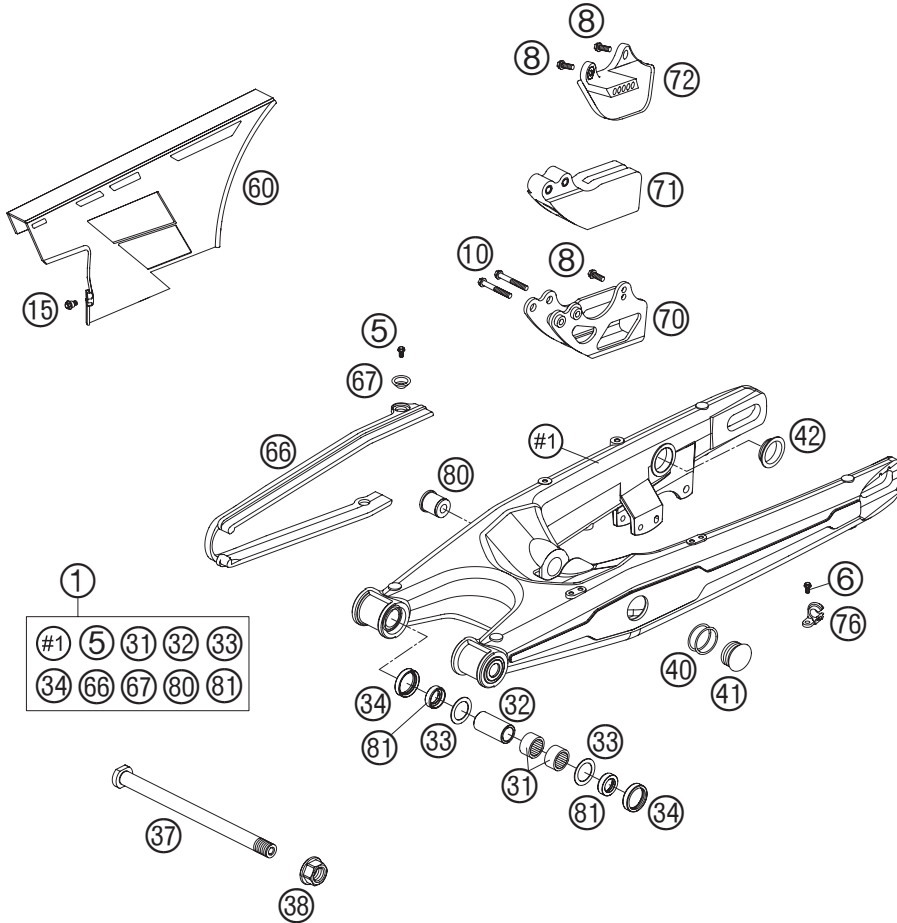

FIG	TEILNR/PARTNR	BEZEICHNUNG	DESCRIPTION	QTY
1	800.04.030.144	SCHWINGE KPL. HUSABERG 05	SWINGARM CPL. HUSABERG 05	1
1	800.04.030.244	SCHWINGE KPL. HUSABERG FS	SWINGARM CPL. HUSABERG FS	1
5	0015 060123	SK.BUNDSCHRAUBE M 6X12 SW=8	HH COLLAR SCREW M 6X12 WS=8	2
6	0015 050123	SK.BUNDSCHRAUBE M 5X12 SW=8	HH COLLAR SCREW M 5X12 WS=8	2
8	0015 060163	SK.BUNDSCHRAUBE M 6X16 SW=8	HH COLLAR SCREW M 6X16 WS=8	2
10	0015 060453	SK.BUNDSCHRAUBE M 6X45 SW=8	HH COLLAR SCREW M 6X45 WS=8	2
15	590.01.092.050	SONDERSCHRAUBE M6X12,5 SW=8	SPECIAL SCREW M6X12,5 WS=8	3
31	580.33.097.000	NADELLAGER HK 2216	NEEDLE BEARING HK 2216	4
32	800.04.032.100	LAGERHÜLSE SCHWINGENLAGER	BUSH. SLEEVE SWINGARM BEAR. 05	2
33	546.03.036.000	ANLAUFSCHIBE 22,2X31,7X1	STOP DISK 22,2X31,7X1	2
34	0760 253270	WELLENDICHRING 25X32X7	SHAFT SEAL RING 25X32X7	4
37	800.04.037.100	SCHWINGARMBOLZEN L=237MM	SWINGARM BOLT L=237MM	1
38	548.04.038.000	STOPPMUTTER M16X1,5 SW=19	SELF LOCK.NUT M16X1,5 WS=19	03
40	0770 253240	O-RING 25,30X2,40 NBR70	O-RING 25,30X2,40 NBR70	4
41	800.04.041.000	VERSCHLUSSKAPPE SCHWINGE	CLOSING COVER SWINGARM	04
42	584.04.041.100	VERSCHLUSSKAPPE RUND	CLOSING COVER ROUND	03
60	800.04.060.100	KETTENSCHUTZ FE	CHAIN GUARD FE	05
66	800.04.066.000	KETTENGLEITSCHUTZ	CHAIN SLIDING GUARD	04
67	461.04.066.050	BÜCHSE F.KETTENGLEITSCHUTZ	BUSH FOR CHAIN SLIDER GUARD	02
70	502.07.070.044	HALBLECH KETTENFÜHRUNG '94	RETAINING PLATE CHAIN GUIDE '94	1
71	546.07.066.100	KETTENFÜHRUNG HINTEN '94	CHAIN GUIDE REAR '94	1
72	800.04.070.000	KETTENFÜHRUNG FS 2005	CHAIN GUIDE FS 2005	1
76	546.11.076.100	HALTESCHELLE FÜR BREMSSCHL.'96	RETAIN.CLAMP FOR BRAKE HOSE '96	2
80	800.04.080.100	BUCHSE FEDERBEINAUFN. 2005	BUSHING SUPPORT MONOSH. 2005	1
81	800.04.034.000	TASSE FÜR WELLENDICHRING	BUCKET F. SHAFT SEAL RING	04



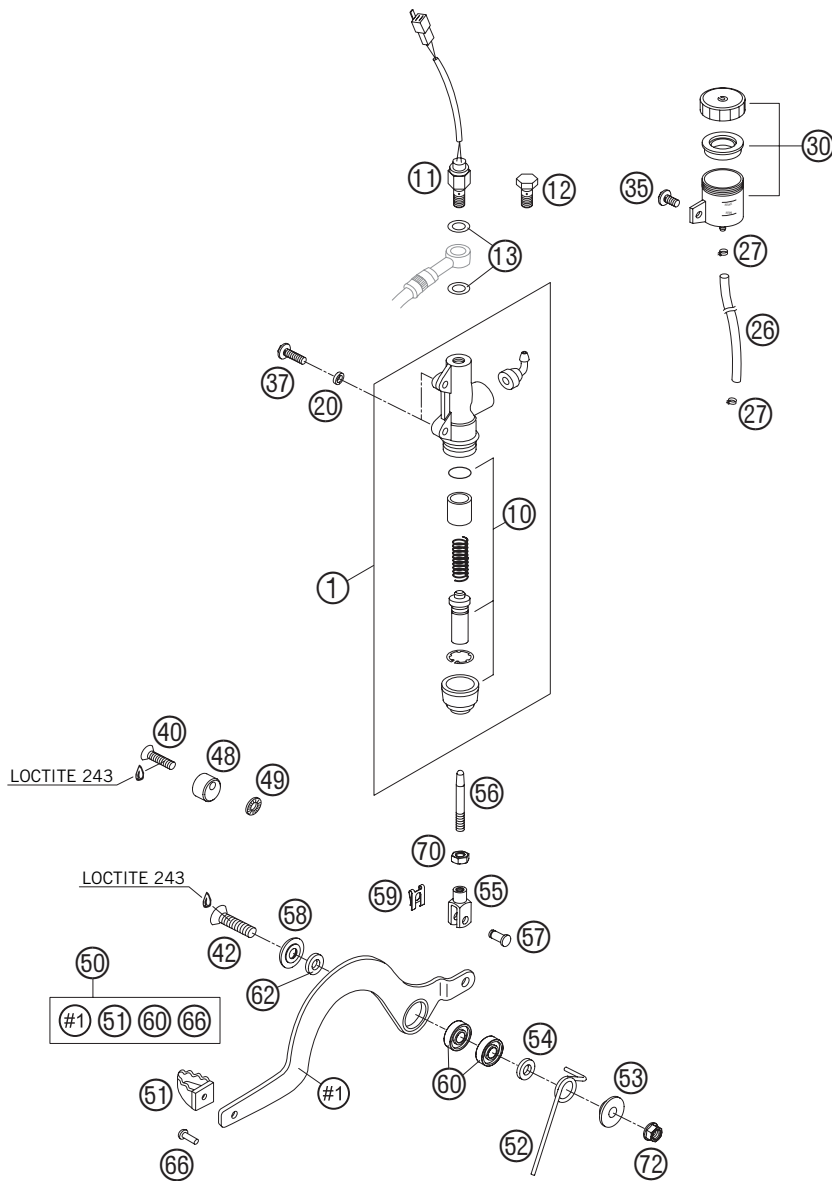

FIG	TEILNR/PARTNR	BEZEICHNUNG	DESCRIPTION	QTY
1	503.13.060.100	FUSSBREMSZYL. 13MM NATUR 2001	FOOTBRAKECYL. 13MM NATURE 2001	1
10	545.13.150.000	REP.SATZ KOLBEN 13MM	REPAIR KIT PISTON 13MM	1
11	503.11.051.100	BREMSLICHTSCHALTER HINTEN '98 FE+FS (EU+AUS)	BRAKE LIGHT SWITCH REAR '98 FE+FS (EU+AUS)	1
12	502.13.025.000	HOHLSCHRAUBE M10X1X19 FE+FS (USA)	HOLLOW SCREW M10X1X19 FE+FS (USA)	1
13	420.13.226.000	CU-DICHTRING DIN7603-10X16X1	CU-SEAL RING DIN7603-10X16X1	2
20	800.04.060.050	BÜCHSE 6,2X10X2,5MM 04	BUSHING 6,2X10X2,5MM 04	2
26	580.07.016.101	SCHLAUCH FÜR RESERVOIR 6X1,5	HOSE FOR RESERVOIR 6X1,5	0,28
27	580.07.017.000	YDNAC KLAMMER 10101 (9MM)	YDNAC CLAMP 10101 (9MM)	2
30	545.13.030.044	BREMSFLÜSSIGKEITSRESERVOIR '89	BRAKE FLUID RESERVOIR '89	1
35	0014 060103	SK.BUNDSCHRAUBE M 6X10 SW=8	HH COLLAR SCREW M 6X10 WS=8	1
37	0014 060203	SK.BUNDSCHRAUBE M 6X20 SW=8	HH COLLAR SCREW M 6X20 WS=8	2
40	0991 060253	SENKSCHRAUBE DIN7991-M 6X25	FLAT HEAD SCREW DIN7991-M 6X25	1
42	0991 080453	SENKSCHRAUBE DIN7991-M 8X45	FLAT HEAD SCREW DIN7991-M 8X45	1
48	800.13.048.000	EXZENTER BREMSHEBELANSCHLAG 04	ECCENTRIC BRAKE LEVER STOP 04	1
49	0797 060003	ZAHNSCHEIBE DIN6797-J 6,4	TOOTH LOCK WASH. DIN6797-A 6,4	1
50	800.13.050.044	FUSSBREMSHEBEL KPL. 04	REAR BRAKE LEVER CPL. 04	1
51	800.13.051.000	AUFTRITT FÜR FUSSBREMSHEBEL 04	BRAKE LEVER PEDAL 04	1
52	800.13.052.000	RÜCKHOLFEDER FUSSBREMSHEBEL 04	RETAIN.SPRING REAR BR.LEVER 04	1
53	800.13.053.100	BUNDBÜCHSE 8,2X13X24X5,5 05	COLLAR. BUSH.8,2X13X24X5,5 05	1
54	800.13.054.100	DISTANZBÜCHSE 8,2X16X3 MM 05	DISTANCE SPACER 8,2X16X3 MM 05	1
55	800.13.055.000	GABELSTÜCK FUSSBREMSBETÄT. 04	FORK PART REAR BRAKE CONTR. 04	1
56	800.13.056.000	DRUCKSTANGE FUSSBREMSBETÄT. 04	PRESSURE ROD REAR BRAKE CON.04	1
57	800.13.057.000	BEFESTIGUNGSBOLZEN 04	MOUNTING BOLT 04	1
58	800.13.058.000	FASSONSCHLEIBE 04	SPECIAL WASHER 04	1
59	800.13.059.000	SL-SICHERUNG 6 MBO 08	SL-CIRCLIP 6 MBO 08	1
60	0625 006087	RILLENKUGELLAGER 608 2RS C3	GROOVED BALL BEAR. 608 2RS C3	2
62	0137 080003	FEDERSCHLEIBE DIN0137-B 8	SPRING WASHER DIN137 B8	1
66	0660 050167	HALBRUNDNIETE DIN0660- 5,0X16	RIVET DIN0660- 5,0X16	1
70	0934 060003	SK.MUTTER DIN 934 M6	HEXAGON NUT DIN0934-M 6	1
72	543.10.086.200	STOVER-FLANSCHMUTTER M8 10.9	SELF LOCKING NUT M8 10.9	1

FIG	TEILNR/PARTNR	BEZEICHNUNG	DESCRIPTION	QTY
1*	1245.7B02	MONOSHOCK HUSABERG FE 2006	MONOSHOCK HUSABERG FE 2006	1
1*	1245.7B03	MONOSHOCK HUSABERG FS 2006	MONOSHOCK HUSABERG FS 2006	1
3	0912 100606	ISK.SCHRAUBE DIN0912-M10X 60	AH SCREW DIN0912-M10X60	1
4*	0015.120556S	SK.BUNDSCHR. M12X55 SW=13 '06	HH COLLAR M12X55 WS=13 06	1

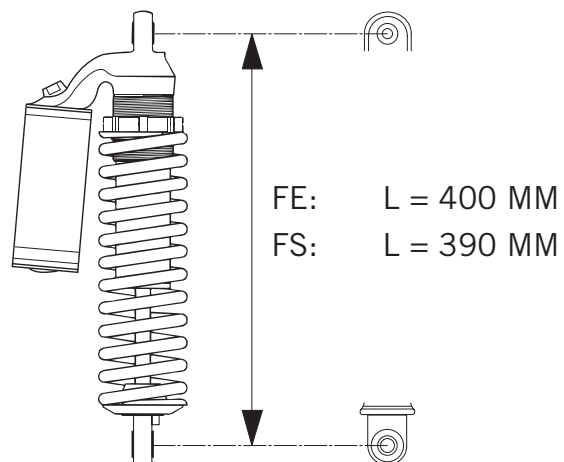
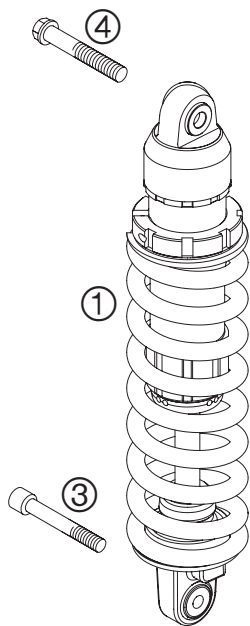
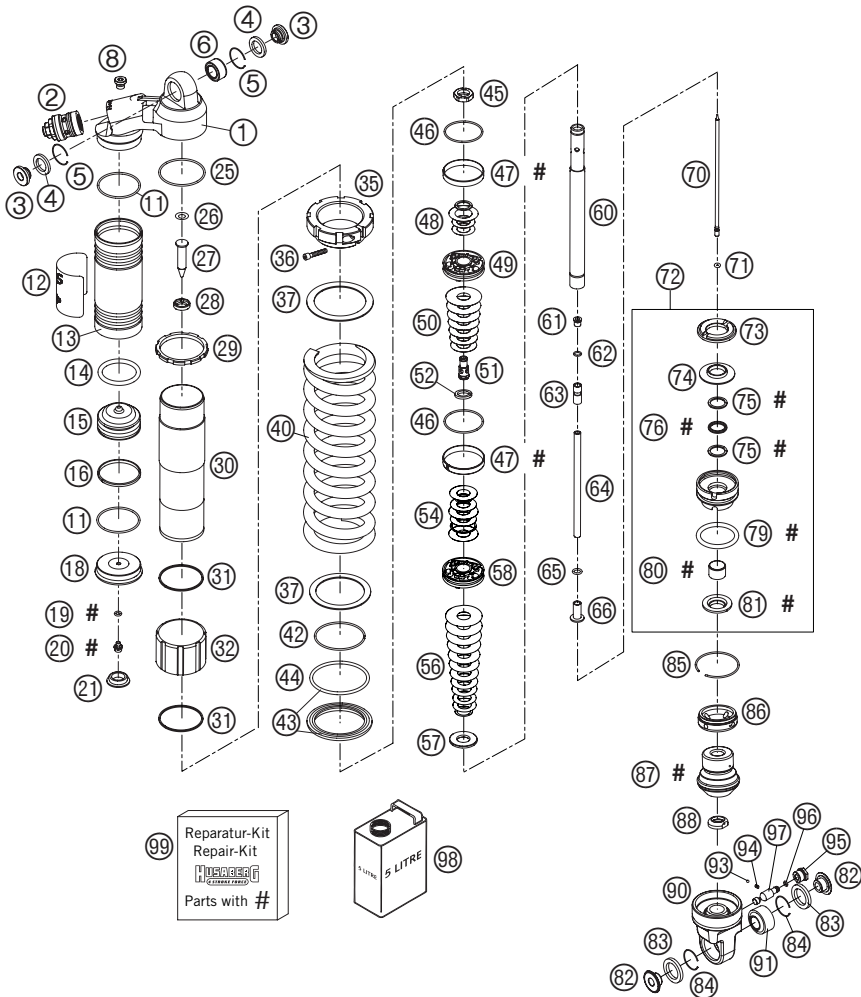

FIG	TEILNR/PARTNR	BEZEICHNUNG	DESCRIPTION	QTY
1	5018.0357	FEDERBEINGEH.30,5 B21 82GR '03	SHOCK ABS.CASE 30,5 B21 82GR03	1
2	5018.0213S6	DCC-DRUCKSTUFENREGUL. KPL. 04	DCC-COMPR.DAMP.CONTROL CPL. 04	1
3	4618.0061	ADAPTER-BUCHSE 12X26	ADAPTOR-BUSH 12X26	2
4	4618.0003	DICHTRING KGW D=25	OIL SEAL KGW D=25	2
5	5018.0168	SCHEIBE KGW D=25	WASHER KGW D=25	2
6	5018.0005	LAGER KGW 1525 HD	BUSHING KGW 1525 HD	1
8	5018.0095	ENTLÜFTUNGSSCHRAUBE R 1/8	BLEED PLUG R 1/8	1
11	4681.0340	O-RING NBR 45X2	O-RING NBR 45X2	2
12	5200.0041	WP CAUTION (PDS KTM) 58X83	WP CAUTION (PDS KTM) 58X83	1
13*	5018.0096S	RESERVOIRSCHRAUBE L140 D96	RESERVOIR SCREW L140 D46	1
14	4681.1043	O-RING VITON 35X5	O-RING VITON 35X5	1
15	5018.0108	TRENNKOLBEN D=46; H=29	SEPARATION PISTON D=46, H=29	1
16	4681.0324	KOLBENRING 3,9X1,5X138	PISTON RING 3,9X1,5X138	1
18	4681.1209	RESERVOIRKAPPE D=46	RESERVOIR CAP D=46	1
19	4681.0893	O-RING NBR 5,28X1,78	O-RING NBR 5,28X1,78	1
20	3612.0151	VERSCHLUSSSCHRAUBE M5X6	SCREW PLUG M5X6	1
21	4681.1208	GUMMIKAPPE "NICHT ÖFFNEN"	RUBBER CAP "DO NOT OPEN"	1
25	5018.0097	O-RING 52X2	O-RING 52X2	1
26	5018.0177	SCHEIBE 16X8,2X0,6	WASHER 16X8,2X0,6	1
27*	5018.0488	NADEL D=11,4 D=6, L=57	NEEDLE D=11,4 D=6, L=57	1
28	5018.0437	SCHRAUBENKAPPE M20X1 D=11,5 H5	SCREW CAP M20X1 D=11,5 H=5	1
29	5018.0270	SICHERUNGSSCHEIBE	LOCK WASHER	1
30	5018.0442	ROHR L=195 PDS	TUBE L=195 PDS	1
31	5018.0133	SPRENGRING 50X1,5	CIRCLIP 50X1,5	2
32	5018.0081	FEDERFÜHRUNG L=40	SPRING GUIDANCE L=40	1
35	5018.0433	EINSTELLRING FEDER M56X1	SPRING RETAINER M56X1	1
36	0912 050303	ISK.SCHRAUBE DIN 912 M5X30	AH SCREW DIN0912-M 5X30	1
37	5018.0114	ZWISCHENRING F. FEDER	INTERM.RING SCREW SPRING RET.	2
40*	9121.0004	FEDER 250 80N/MM D=12,5 (62)	SPRING 250 80N/MM D=12,5 (62)	1
40*	9121.0003	FEDER 250 76N/MM D=12,5 (59)	SPRING 250 76N/MM D=12,5 (59)	X
40*	9121.0005	FEDER 250 84N/MM D=13,0 (62)	SPRING 250 84N/MM D=13,0 (62)	X
42	5018.0273	SPRENGRING 58,2X2	CIRCLIP 58,2X2	1
43*	5018.0463S	FEDERTELLER D=80 MIT O-RING 05	SPRING RET. D=80 W. O-RING 05	1
44	5018.0352	O-RING VITON 66,27X3,53	O-RING VITON 66,27X3,53	1
45	5018.0141	KOLBENSTANGENMUTTER M16X1	PISTON ROD NUT M16X1	1



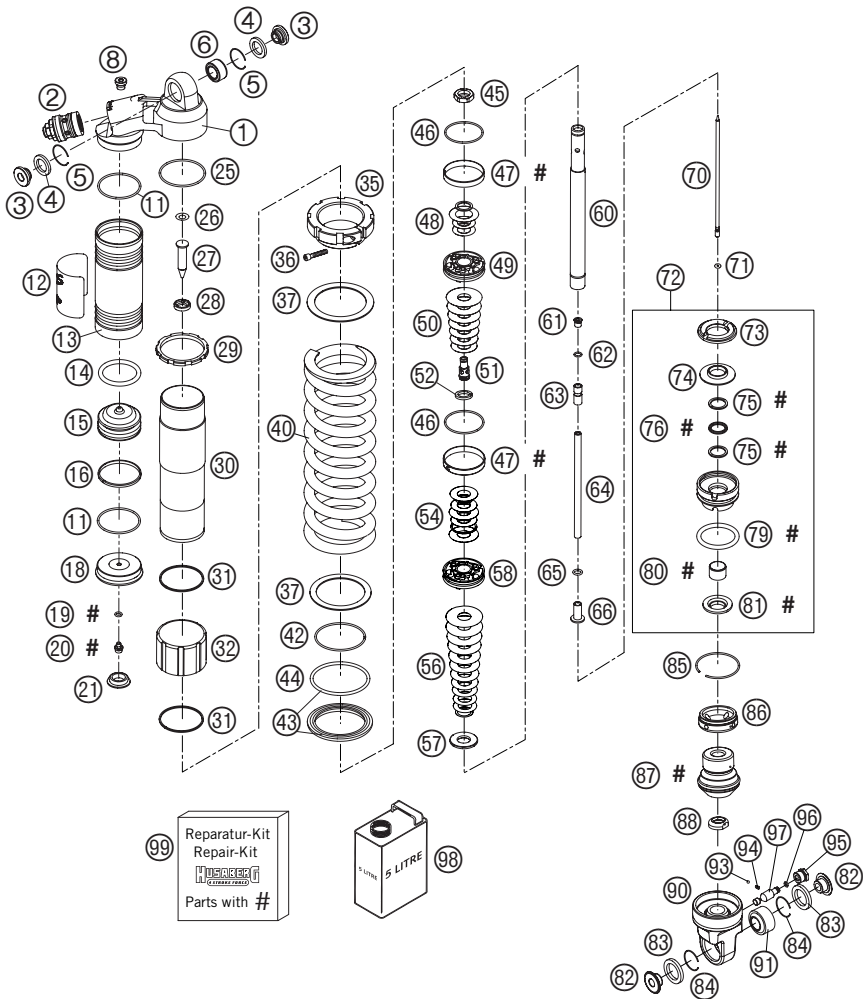

FIG	TEILNR/PARTNR	BEZEICHNUNG	DESCRIPTION	QTY
46	5018.0099	O-RING VITON 44,17X1,78	O-RING VITON 44,17X1,78	2
47	5018.0135	KOLBENRING 50-8	PISTON RING 50-8	2
48*	5018.0034	DISTANZPLATTE 16X20X0,30	BACKPLATE 16X20X0,30	X
48*	5018.0055	SCHEIBE 16X30X0,20	SHIM 16X30X0,20	X
48*	5018.0056	SCHEIBE 16X32X0,20	SHIM 16X32X0,20	X
48*	5018.0057	SCHEIBE 16X34X0,20	SHIM 16X34X0,20	X
48*	5018.0058	SCHEIBE 16X36X0,20	SHIM 16X36X0,20	X
48*	5018.0210	SCHEIBE 16X21X1	WASHER 16X21X1	X
49*	5018.0311	KOLBEN 6+6X7/4,5 VB 1,0	PISTON 6+6X7/4,5 VB 1,0	1
50*	5018.0034	DISTANZPLATTE 16X20X0,30	BACKPLATE 16X20X0,30	X
50*	5018.0065	SCHEIBE 16X32X0,25	SHIM 16X32X0,25	X
50*	5018.0068	SCHEIBE 16X38X0,25	SHIM 16X38X0,25	X
50*	5018.0078	SCHEIBE 16X40X0,30	SHIM 16X40X0,30	X
51*	5018.0485	HALTER D=16 M16X1 L=48	HOLDER D=16 M16X1 L=48	1
52*	5018.0499	DISTANZPLATTE D=23 D=16 H3	BACKPLATE D=23 D=16 H3	1
54	5018.0034	DISTANZPLATTE 16X20X0,30	BACKPLATE 16X20X0,30	X
54	5018.0045	SCHEIBE 16X28X0,15	SHIM 16X28X0,15	X
54	5018.0054	SCHEIBE 16X28X0,20	SHIM 16X28X0,20	X
54	5018.0056	SCHEIBE 16X32X0,20	SHIM 16X32X0,20	X
54	5018.0057	SCHEIBE 16X34X0,20	SHIM 16X34X0,20	X
54	5018.0067	SCHEIBE 16X36X0,25	SHIM 16X36X0,25	X
56*	5018.0054	SCHEIBE 16X28X0,20	SHIM 16X28X0,20	X
56*	5018.0055	SCHEIBE 16X30X0,20	SHIM 16X30X0,20	X
56*	5018.0056	SCHEIBE 16X32X0,20	SHIM 16X32X0,20	X
56*	5018.0057	SCHEIBE 16X34X0,20	SHIM 16X34X0,20	X
56*	5018.0058	SCHEIBE 16X36X0,20	SHIM 16X36X0,20	X
56*	5018.0068	SCHEIBE 16X38X0,25	SHIM 16X38X0,25	X
56*	5018.0060	SCHEIBE 16X40X0,20	SHIM 16X40X0,20	X
56*	5018.0061	SCHEIBE 16X42X0,20	SHIM 16X42X0,20	X
56*	5018.0071	SCHEIBE 16X44X0,25	SHIM 16X44X0,25	X
57*	5018.0233	SCHEIBE ZUGSTUFE D=34; H=2	REBOUND DISC D=34, H=2	1
58*	5018.0446	KOLBEN 6+6X3,5/4,5	PISTON 6+6X3,5/4,5	1
60*	5018.0486	KOLBENSTANGE D=18 L=146 M16X1	PISTON ROD D=18 L=146 M16X1	1
61	5018.0200	BÜCHSE M8X1	BUSH M8X1	1
62	5018.0157	O-RING VITON 7X1,5	O-RING VITON 7X1,5	1

FIG	TEILNR/PARTNR	BEZEICHNUNG	DESCRIPTION	QTY
63	5018.0439	NADELSITZ M8X1 D=5,5	NEEDLE SEAT M8X1 D=5,5	05 1
64*	5018.0489	ROHR M8X1 L=145,4	TUBE M8X1 L=145,4	1
65	4860.0049	O-RING NBR 8X2	O-RING NBR 8X2	1
66	5018.0279	ROHR ADAPTOR M8X1 L=23	TUBE ADAPTOR M8X1 L=23	1
70*	5018.0490	NADEL L=169	NEEDLE L=169	1
71	4681.1265	O-RING VITON 2,2X1,6	O-RING VITON 2,2X1,6	1
72	5018.0435S	ADAPTER KPL. D=50 H=29	ADAPTOR CPL. D=50 H=29	1
73	5018.0107	GUMMI ZUGSTUFE	REBOUND RUBBER	1
74	5018.0113	STAHSCHLEIBE 18,5X43,7X6	STEEL DISC 18,5X43,7X6	1
75	5018.0102	SICHERHEITSRING 22,55X1,5	BACKUPRING 22,55X1,5	2
76	5018.0101	DICHRING QUARD 18X2,62	QUAD RING 18X2,62	1
79	5018.0103	O-RING 41X5	O-RING 41X5	1
80	4618.0119	DISTANZBÜCHSE 18X20X12	DU-BUSH 18X20X12	1
81	5018.0082	STAUBMANSCHETTE 1835	DUST SEAL 1835	1
82	5018.0153	ADAPTER-BÜCHSE KGW 32X10X26	ADAPTOR-BUSH KGW 32X10X26	2
83	5018.0159	WELLENDICHRING KGW D=32	SHAFT SEAL RING KGW D=32	2
84	5018.0175	SICHERUNGSRING KGW D=32	CIRCLIP KGW D=32	2
85	5018.0126	SICHERUNGSRING 53X1,75	CIRCLIP 53X1,75	1
86*	5018.0487	DECKEL D=50	COVER D=50	1
87*	5018.0480	GUMMIPUFFER SXS 2005	BUMP RUBBER SXS 2005	1
88*	5018.0481	MUTTER M18X1	NUT M18X1	1
90*	5018.0497	FEDERBEINUNTERT.54X20X32	SHOCK ABS.BOTTOM 54X20X32	1
91	5018.0179	SCHWENKLAGER KGW 1632	PIVOT BEARING KGW 1632	1
93	4054.0603	STAHLKUGEL D=3MM	STEEL BALL D=3MM	1
94	4860.0028	FEDER D=2,9 L=7,9	SPRING D=2,9 L=7,9	1
95	5018.0281	RESERVOIRKAPPE M14X1	RESERVOIR CAP M14X1	1
96	5018.0222	O-RING NBR 4X1,5	O-RING NBR 4X1,5	1
97	5018.0434	EINSTELLSCHRAUBE 80 GRAD L=39	ADJUSTING SCREW 80 DEG. L=39	1
98*	5018.0466S1	DÄMPFERÖL 5 LT	SHOCK ABSORBER FLUID 5 LT	05 1
99*	R120.11	REP.SATZ DICHT. 5018 PDS	REPAIR KIT GASKET 5018 PDS	06 1

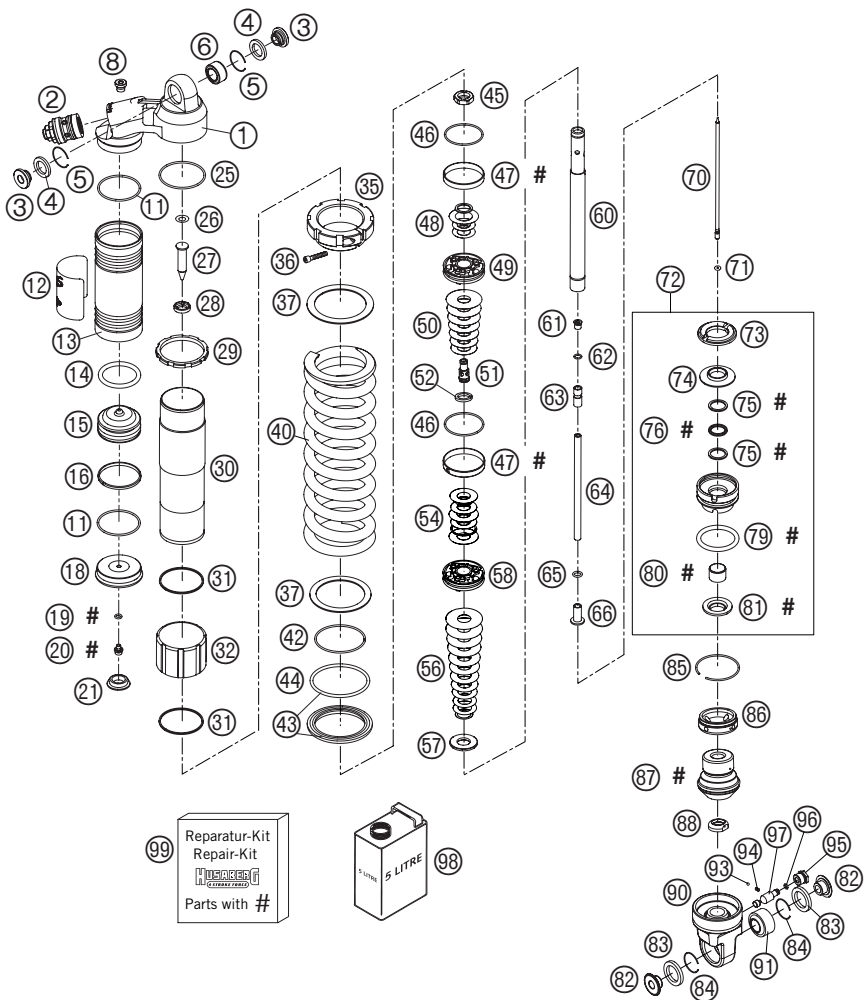
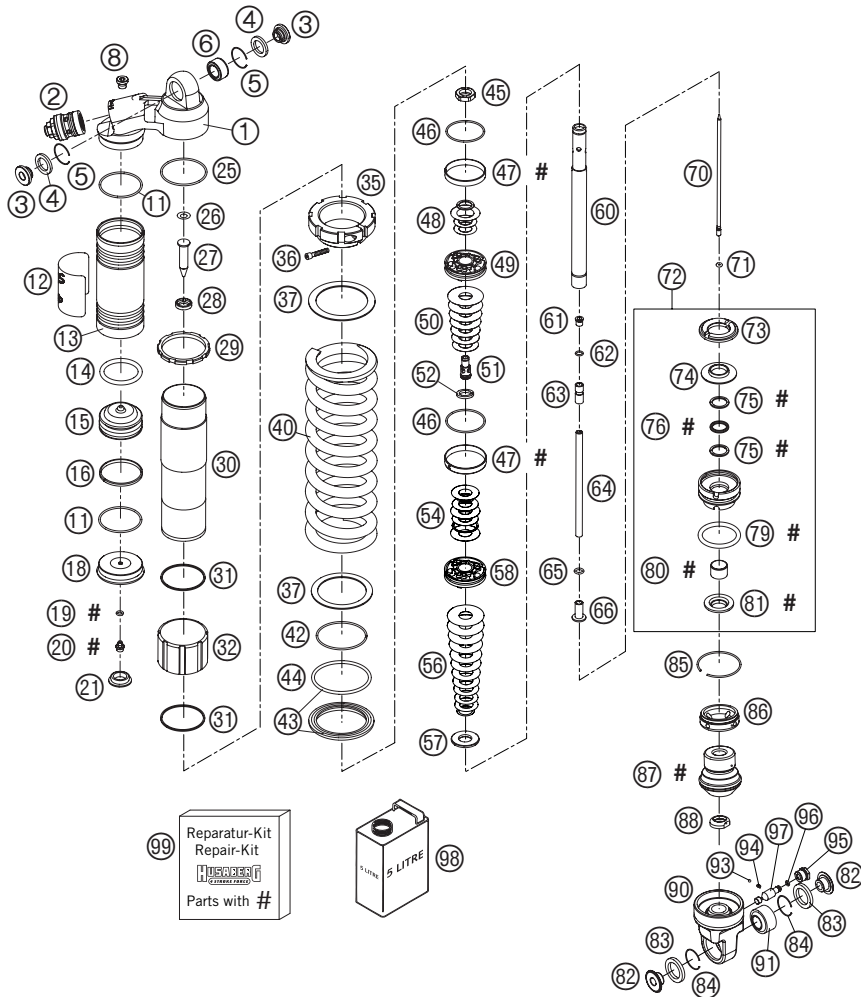

FIG	TEILNR/PARTNR	BEZEICHNUNG	DESCRIPTION	QTY
1	5018.0357	FEDERBEINGEH.30,5 B21 82GR '03	SHOCK ABS.CASE 30,5 B21 82GR03	1
2*	5018.0213S4	DCC-DRUCKSTUFENREGUL. KPL. 03	DCC-COMPR.DAMP.CONTROL CPL. 03	1
3	4618.0061	ADAPTER-BUCHSE 12X26	ADAPTOR-BUSH 12X26	2
4	4618.0003	DICHTRING KGW D=25	OIL SEAL KGW D=25	2
5	5018.0168	SCHEIBE KGW D=25	WASHER KGW D=25	2
6	5018.0005	LAGER KGW 1525 HD	BUSHING KGW 1525 HD	1
8	5018.0095	ENTLÜFTUNGSSCHRAUBE R 1/8	BLEED PLUG R 1/8	1
11	4681.0340	O-RING NBR 45X2	O-RING NBR 45X2	2
12	5200.0041	WP CAUTION (PDS KTM) 58X83	WP CAUTION (PDS KTM) 58X83	1
13	5018.0096	RESERVOIRSCHRAUBE L140 GRAU	RESERVOIR SCREW L140 GREY	1
14	4681.1043	O-RING VITON 35X5	O-RING VITON 35X5	1
15	5018.0108	TRENNKOLBEN D=46; H=29	SEPARATION PISTON D=46, H=29	1
16	4681.0324	KOLBENRING 3,9X1,5X138	PISTON RING 3,9X1,5X138	1
18	4681.1209	RESERVOIRKAPPE D=46	RESERVOIR CAP D=46	1
19	4681.0893	O-RING NBR 5,28X1,78	O-RING NBR 5,28X1,78	1
20	3612.0151	VERSCHLUSSSCHRAUBE M5X6	SCREW PLUG M5X6	1
21	4681.1208	GUMMIKAPPE "NICHT ÖFFNEN"	RUBBER CAP "DO NOT OPEN"	1
25	5018.0097	O-RING 52X2	O-RING 52X2	1
26	5018.0177	SCHEIBE 16X8,2X0,6	WASHER 16X8,2X0,6	1
27	5018.0359	NADEL D=10 L=33/47	NEEDLE D=10 L=33/47	1
28	5018.0437	SCHRAUBENKAPPE M20X1 D=11,5 H5	SCREW CAP M20X1 D=11,5 H=5	1
29	5018.0270	SICHERUNGSSCHEIBE	LOCK WASHER	1
30	5018.0443	ROHR L=193	TUBE L=193	1
31	5018.0133	SPRENGRING 50X1,5	CIRCLIP 50X1,5	2
32	5018.0081	FEDERFÜHRUNG L=40	SPRING GUIDANCE L=40	1
35	5018.0433	EINSTELLRING FEDER M56X1	SPRING RETAINER M56X1	1
36	0912 050303	ISK.SCHRAUBE DIN 912 M5X30	AH SCREW DIN0912-M 5X30	1
37	5018.0114	ZWISCHENRING F. FEDER	INTERM.RING SCREW SPRING RET.	2
40*	9121.0008	FEDER 250 97N/MM	SPRING 250 97N/MM	X
40	9121.0005	FEDER 250 84N/MM D=13,0 (62)	SPRING 250 84N/MM D=13,0 (62)	X
40	9121.0006	FEDER 250 88N/MM D=13,0 (62)	SPRING 250 88N/MM D=13,0 (62)	1
42	5018.0273	SPRENGRING 58,2X2	CIRCLIP 58,2X2	1
43*	5018.0463S	FEDERTELLER D=80 MIT O-RING 05	SPRING RET. D=80 W. O-RING 05	1
44	5018.0352	O-RING VITON 66,27X3,53	O-RING VITON 66,27X3,53	1
45	5018.0141	KOLBENSTANGENMUTTER M16X1	PISTON ROD NUT M16X1	1



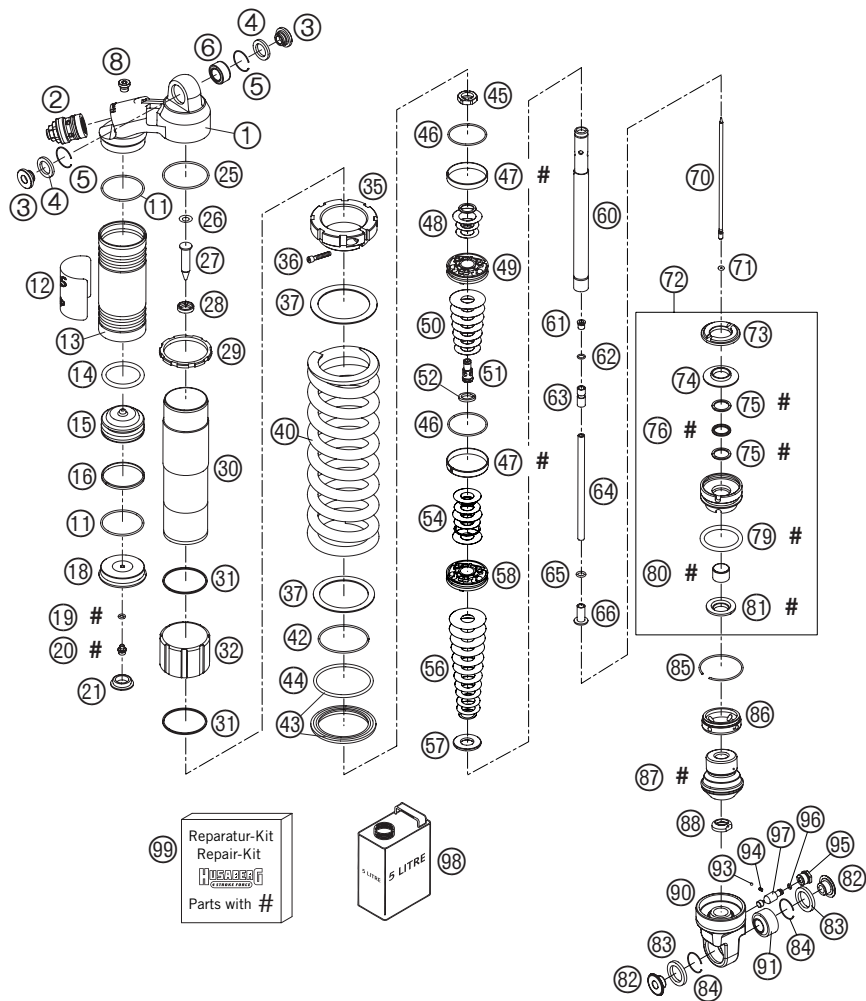

FIG	TEILNR/PARTNR	BEZEICHNUNG	DESCRIPTION	QTY
46	5018.0099	O-RING VITON 44,17X1,78	O-RING VITON 44,17X1,78	2
47	5018.0135	KOLBENRING 50-8	PISTON RING 50-8	2
48	5018.0054	SCHEIBE 16X28X0,20	SHIM 16X28X0,20	X
48	5018.0209	SCHEIBE 21X36X0,25	WASHER 21X36X0,25	X
48	5018.0210	SCHEIBE 16X21X1	WASHER 16X21X1	X
49	5018.0197	KOLBEN 6+6X7/4,5	PISTON 6+6X7/4,5	1
50	5018.0071	SCHEIBE 16X44X0,25	SHIM 16X44X0,25	X
50	5018.0074	SCHEIBE 16X32X0,30	SHIM 16X32X0,30	X
50	5018.0075	SCHEIBE 16X34X0,30	SHIM 16X34X0,30	X
50	5018.0076	SCHEIBE 16X36X0,30	SHIM 16X36X0,30	X
50	5018.0077	SCHEIBE 16X38X0,30	SHIM 16X38X0,30	X
50	5018.0078	SCHEIBE 16X40X0,30	SHIM 16X40X0,30	X
50	5018.0079	SCHEIBE 16X42X0,30	SHIM 16X42X0,30	X
51	5018.0269	VERBUNDBÜCHSE D25XD16X14,5/D	SANDWICH BUSH D25XD16X14,5/D	1
54	4681.1637	DRUCKRING 36X32,25	PRESSURE RING 36X32,25	X
54	5018.0034	DISTANZPLATTE 16X20X0,30	BACKPLATE 16X20X0,30	X
54	5018.0049	SCHEIBE 16X36X0,15	SHIM 16X36X0,15	X
54	5018.0056	SCHEIBE 16X32X0,20	SHIM 16X32X0,20	X
54	5018.0058	SCHEIBE 16X36X0,20	SHIM 16X36X0,20	X
56	5018.0034	DISTANZPLATTE 16X20X0,30	BACKPLATE 16X20X0,30	X
56	5018.0055	SCHEIBE 16X30X0,20	SHIM 16X30X0,20	X
56	5018.0056	SCHEIBE 16X32X0,20	SHIM 16X32X0,20	X
56	5018.0057	SCHEIBE 16X34X0,20	SHIM 16X34X0,20	X
56	5018.0058	SCHEIBE 16X36X0,20	SHIM 16X36X0,20	X
56	5018.0059	SCHEIBE 16X38X0,20	SHIM 16X38X0,20	X
56	5018.0069	SCHEIBE 16X40X0,25	SHIM 16X40X0,25	X
56	5018.0070	SCHEIBE 16X42X0,25	SHIM 16X42X0,25	X
56	5018.0071	SCHEIBE 16X44X0,25	SHIM 16X44X0,25	X
57*	5018.0288	SCHEIBE ZUGSTUFE D=34; H=10	SHIM REBOUND D=34, H=10	1
58	5018.0197	KOLBEN 6+6X7/4,5	PISTON 6+6X7/4,5	1
60	5018.0291	KOLBENSTANGE D=18 M16X1 '02	PISTON ROD D=18 M16X1 '02	1
61	5018.0200	BÜCHSE M8X1	BUSH M8X1	1
62	5018.0157	O-RING VITON 7X1,5	O-RING VITON 7X1,5	1
63	5018.0439	NADELSITZ M8X1 D=5,5 05	NEEDLE SEAT M8X1 D=5,5 05	1
64	5018.0284	ROHR M8X1 L=143,5	TUBE M8X1 L=143,5	1

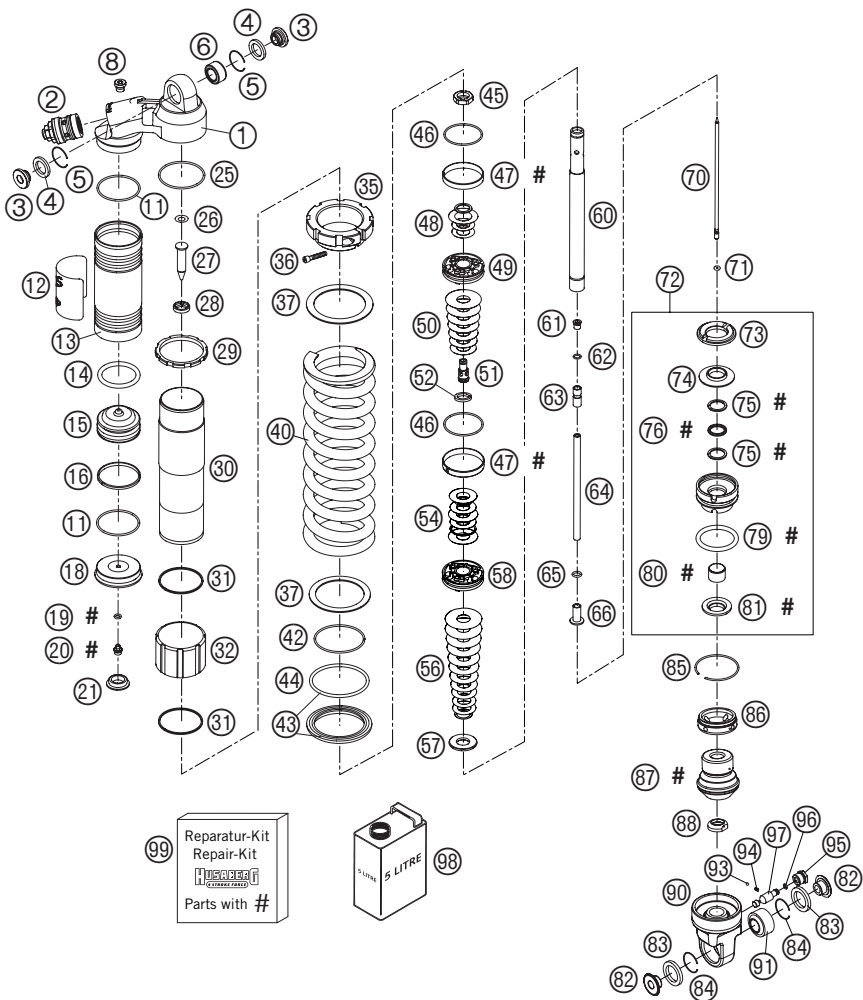
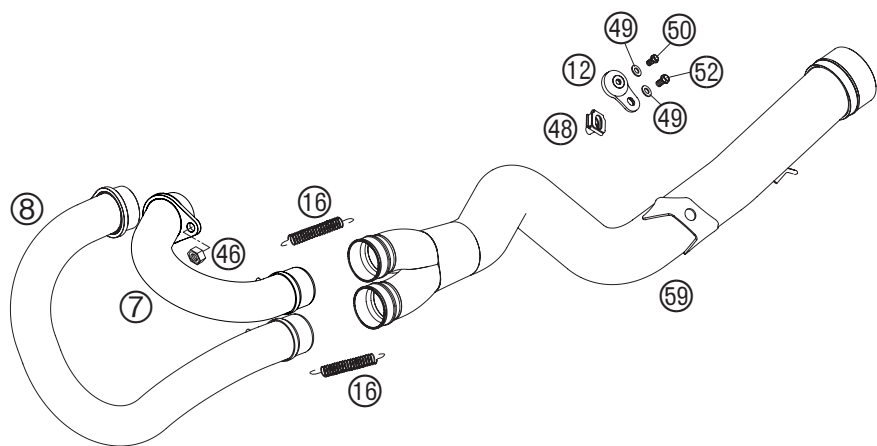
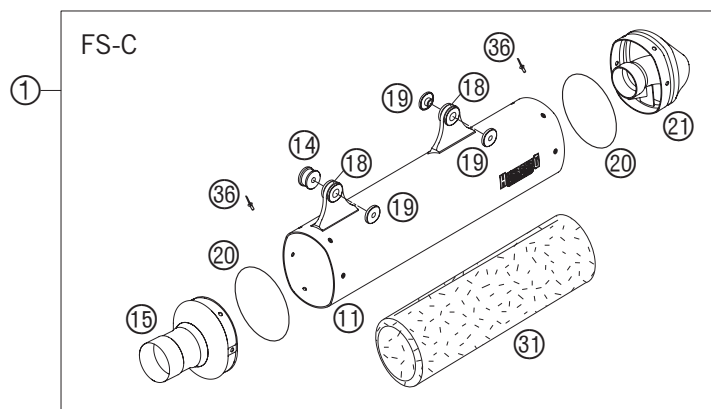

FIG	TEILNR/PARTNR	BEZEICHNUNG	DESCRIPTION	QTY
65	4860.0049	O-RING NBR 8X2	O-RING NBR 8X2	1
66	5018.0279	ROHR ADAPTOR M8X1 L=23	TUBE ADAPTOR M8X1 L=23	1
70	5018.0278	NADEL FÜR ZUGSTUFENVERSTELLUNG	NEEDLE FOR REBOUND MODIFICAT.	1
71	4681.1265	O-RING VITON 2,2X1,6	O-RING VITON 2,2X1,6	1
72*	5018.0435S	ADAPTER KPL. D=50 H=29	ADAPTOR CPL. D=50 H=29	1
73	5018.0107	GUMMI ZUGSTUFE	REBOUND RUBBER	1
74	5018.0113	STAHSCHIBE 18,5X43,7X6	STEEL DISC 18X,5X43,7X6	1
75	5018.0102	SICHERTSRING 22,55X1,5	BACKUPRING 22,55X1,5	2
76	5018.0101	DICHRING QUARD 18X2,62	QUAD RING 18X2,62	1
79	5018.0103	O-RING 41X5	O-RING 41X5	1
80*	4618.0119	DISTANZBÜCHSE 18X20X12	DU-BUSH 18X20X12	1
81	5018.0082	STAUBMANSCHETTE 1835	DUST SEAL 1835	1
82	5018.0153	ADAPTER-BÜCHSE KGW 32X10X26	ADAPTOR-BUSH KGW 32X10X26	2
83	5018.0159	WELLENDICHRING KGW D=32	SHAFT SEAL RING KGW D=32	2
84	5018.0175	SICHERUNGRING KGW D=32	CIRCLIP KGW D=32	2
85	5018.0126	SICHERUNGRING 53X1,75	CIRCLIP 53X1,75	1
86*	5018.0487	DECKEL D=50	COVER D=50	1
87*	5018.0480	GUMMIPUFFER SXS 2005	BUMP RUBBER SXS 2005	1
88*	5018.0481	MUTTER M18X1	NUT M18X1	1
90*	5018.0497	FEDERBEINUNTERT.54X20X32	SHOCK ABS.BOTTOM 54X20X32	1
91	5018.0179	SCHWENKLAGER KGW 1632	PIVOT BEARING KGW 1632	1
93	4054.0603	STAHLKUGEL D=3MM	STEEL BALL D=3MM	1
94	4860.0028	FEDER D=2,9 L=7,9	SPRING D=2,9 L=7,9	1
95	5018.0281	RESERVOIRKAPPE M14X1	RESERVOIR CAP M14X1	1
96	5018.0222	O-RING NBR 4X1,5	O-RING NBR 4X1,5	1
97	5018.0434	EINSTELLSCHRAUBE 80 GRAD L=39	ADJUSTING SCREW 80 DEG. L=39	1
98*	5018.0466S1	DÄMPFERÖL 5 LT 2005	SHOCK ABSORBER FLUID 5 LT 05	1
99*	R120.11	REP.SATZ DICHR. 5018 PDS 06	REPAIR KIT GASKET 5018 PDS 06	1

FIG	TEILNR/PARTNR	BEZEICHNUNG	DESCRIPTION	QTY
7	810.05.007.000	AP-KRÜMMER LI. 450 KPL. 2005	EXH. COLLECTOR L/S 450 CPL. 05	1
7	815.05.007.100	AP-KRÜMMER LI. 550 KPL. 2005	EXH. COLLECTOR L/S 550 CPL. 05	1
7	820.05.007.100	AP-KRÜMMER LI. 650 KPL. 2005	EXH. COLLECTOR L/S 650 CPL. 05	1
8	810.05.008.000	AP-KRÜMMER RE. 450 KPL. 2005	EXH. COLLECTOR R/S 450 CPL. 05	1
8	815.05.008.100	AP-KRÜMMER RE. 550 KPL. 2005	EXH. COLLECTOR R/S 550 CPL. 05	1
8	820.05.008.100	AP-KRÜMMER RE. 650 KPL. 2005	EXH. COLLECTOR R/S 650 CPL. 05	1
12	503.05.012.000	SCHWINGELEMENT FÜR AUSPUFF	SWINGELEMENT FOR EXHAUST PIPE	1
16	503.05.016.000	ZUGFEDER L=62MM ÖSEN BEWEGLICH	TEN.SPRING L=62MM EY.MOVEABLE	2
46	510.10.086.000	SS-MUTTER M 6 CU	SELF LOCKING NUT M 6 COPPER	2
48	502.35.033.200	KLIPS-MUTTERNHALTER M6 KP134	SNAP-NUT HOLDER M6 KP 134	1
49	0125 060003	UNTERLEGSCHIBE DIN0125 A 6,4	WASHER DIN0125-A 6,4	2
50	0015 060163	SK.BUNDSCHRAUBE M 6X16 SW=8	HH COLLAR SCREW M 6X16 WS=8	1
52	0015 060123	SK.BUNDSCHRAUBE M 6X12 SW=8	HH COLLAR SCREW M 6X12 WS=8	1
59	800.05.059.000	ZWISCHENROHR KPL. HUSABERG 05	EXH.INT. TUBE CPL. HUSABERG 05	1





FS-C

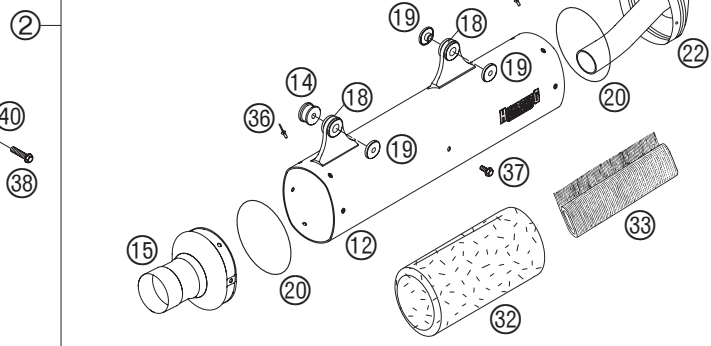
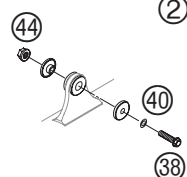

EU+US

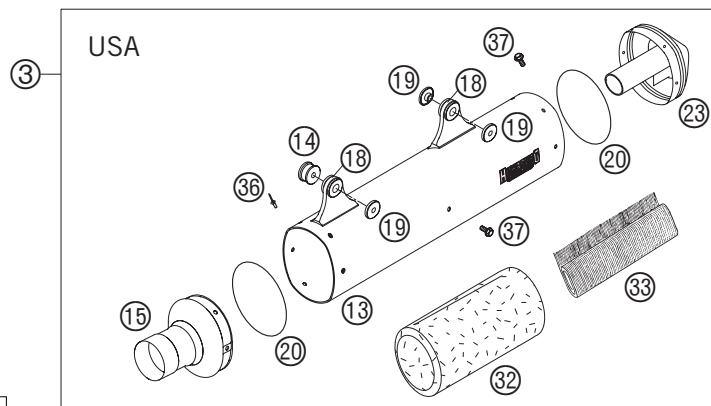

USA

FIG	TEILNR/PARTNR	BEZEICHNUNG	DESCRIPTION	QTY
1	800.05.079.100	ENDDÄMPFER FC 05	SILENCER FC 05	1
2	800.05.079.400	ENDDÄMPFER FE KPL. GEDR. 05	SILENCER FE CPL. THROTT. 05	1
3	800.05.079.300	ENDDÄMPFER SPARKY KPL. 05	SILENCER SPARKY CPL. 05	1
11	800.05.079.150	ENDDÄMPFERHÜLLE FC 05	SILENCER HOUSING FC 05	1
12	800.05.079.250	ENDDÄMPFERHÜLLE FE 05	SILENCER HOUSING FE 05	1
13	800.05.079.350	ENDDÄMPFERHÜLLE SPARKY 05	SILENCER HOUSING SPARKY 05	1
14*	594.05.269.000	BÜCHSE ED-SMR VORNE 2004	BUSHING SIL.-SMR FRONT 2004	X
15	800.05.079.109	ANSCHLUSSKAPPE FC KPL. 05	SIL. CONNECT. CAP FC CPL. 05	1
16	503.05.016.000	ZUGFEDER L=62MM ÖSEN BEWEGLICH	TEN.SPRING L=62MM EY.MOVEABLE	1
18	546.05.068.000	DÄMPFUNGSELEMENT SCHWARZ	EXHAUST BRACKET RUBBER BLACK	X
19	546.05.069.000	BUNDBÜCHSE 7,5X12X28X7,6	BUSHING 7,5X12X28X7,8 '96	X
20	0770 740015	O-RING 74,00X1,50 FKM 75SH	O-RING 74,00X1,50 FKM 75SH	2
21	800.05.079.106	ED-ENDKAPPE FC KPL. 2005	SIL. END CAP FC CPL. 2005	1
22	800.05.079.406	ED-ENDKAPPE FE KPL. GEDR. 05	SIL. END CAP FE CPL. THROTT.05	1
22	800.05.079.206	ED-ENDKAPPE FE KPL. 05	SIL. END CAP FE CPL. 05	X
23	800.05.079.306	ED-ENDKAPPE SPARKY KPL. 05	SIL. END CAP SPARKY CPL. 05	1
31	590.05.078.550	DÄMMSTOFF 550GRAMM L=550MM SX	STUFF.YARN 550GRAMM L=550MM SX	1
32	587.05.078.350	DÄMMSTOFF 350 GRAMM '99	STUFFINGYARN 350 GRAMM '99	1
33	590.05.078.076	DÄMMSTOFF-MATTE 560X340/76G 04	STUFFING YARN 560X340X76G 04	1
36*	0011 480800	BLINDNIETE 4,8X 8 NIRO	DUMMY RIVET 4,8X 8 NIRO	12(6)
37	0009 050103	GEW.FURCHSCHRAUBE M 5,0X10 SK	SPECIAL SCREW M 5,0X10	2(8)
38	0015 060253	SK.BUNDSCHRAUBE M 6X25 SW=8	HH COLLAR SCREW M 6X25 WS=8	2
40	0137 060003	FEDERSCHEIBE DIN 137 B 6	SPRING WASHER DIN0137-B 6	2
44	565.09.064.100	STOVER-FLANSCHMUTTER M6 10.9	SELF LOCKING NUT M6 10.9	2

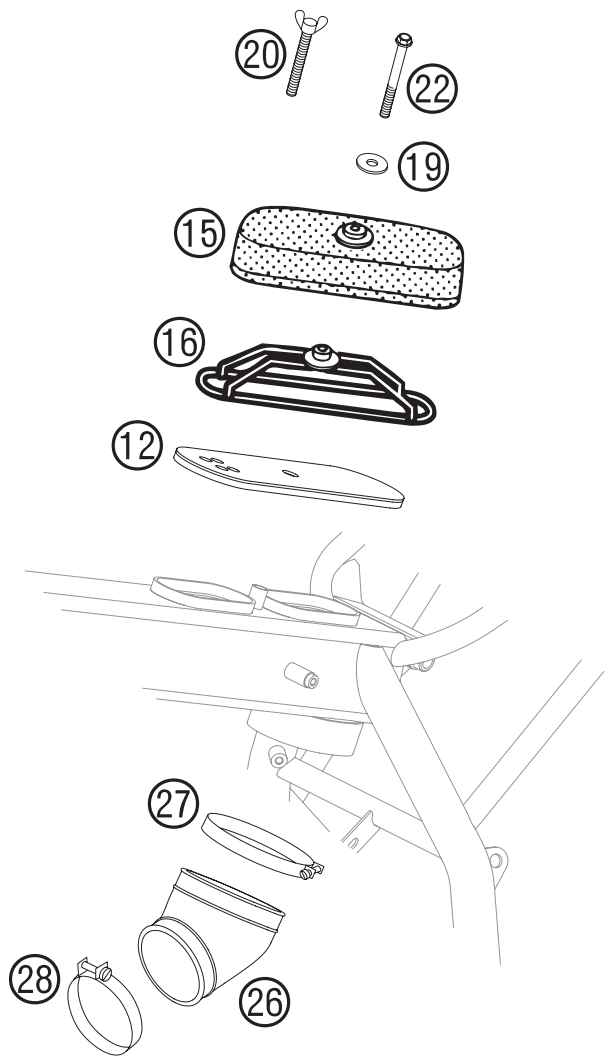

FIG	TEILNR/PARTNR	BEZEICHNUNG		DESCRIPTION	QTY
12	800.06.012.000	ANSAUGDROSSEL FE+FS (EU+AUS)	04	INTAKE THROTTLE FE+FS (EU+AUS)	04 1
15	800.06.015.000	LUFTFILTER	04	AIR FILTER	04 1
16	800.06.016.000	FILTERTRÄGER	04	AIR FILTER CARRIER	04 1
19	0021 060003	SCHEIBE DIN 9021 A 6,4		WASHER DIN9021-A 6,4	1
20	0316 060503	FLÜGELSCHRAUBE M6X50		THUMB SCREW M6X50	1
22	0015 060603	SK.BUNDSCHRAUBE M 6X60 SW=8		HH COLLAR SCREW M 6X60 WS=8	1
26	800.06.026.000	VERGASERMANSCHETTE 550/650	04	CARB. CONNECT. BOOT 550/650	04 1
26	800.06.026.100	VERGASERMANSCHETTE 450/501	04	CARB. CONNECT. BOOT 450/501	04 1
27	585.06.027.000	SCHLAUCHBINDER 70-90MM		HOSE CLAMP 70-90MM	1
28	510.06.027.000	SCHLAUCHBINDER 50-70MM		HOSE CLAMP 50-70MM	1

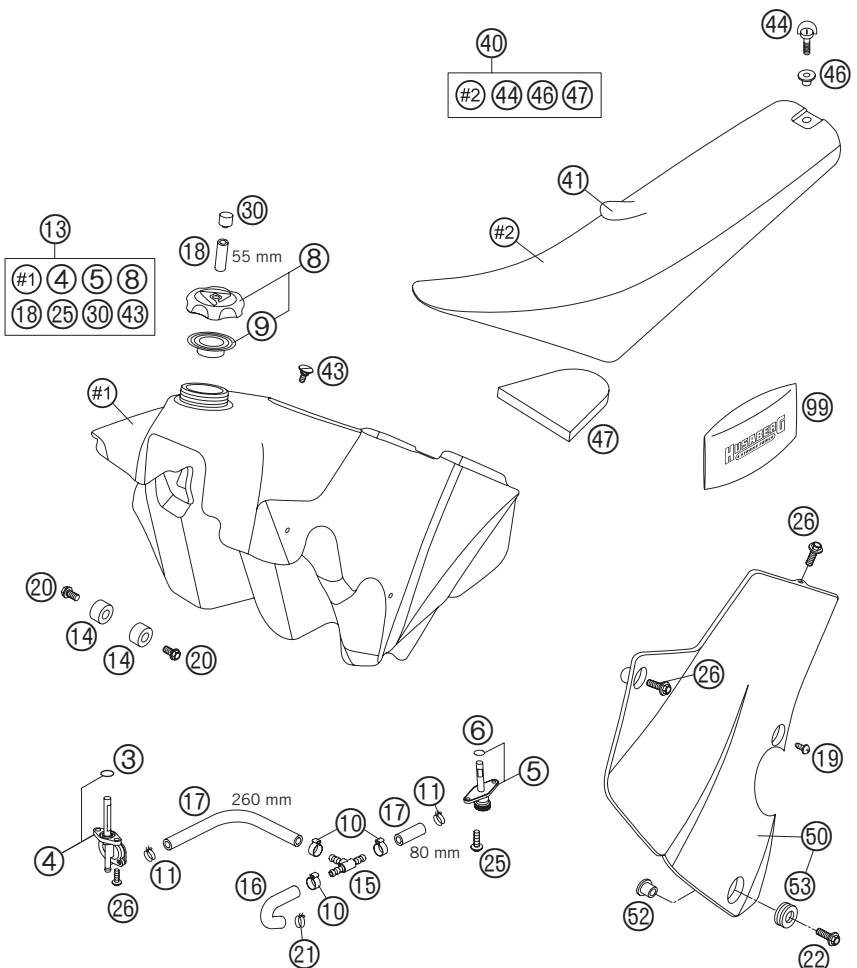

FIG	TEILNR/PARTNR	BEZEICHNUNG	DESCRIPTION	QTY
3*	0770 130023	O-RING 13,00X2,30	O-RING 13,00X2,30	X
4*	503.07.005.000	BENZINHAHN MIKUNI ON/OFF 2001	GAS COCK MIKUNI ON/OFF 2001	1
5*	585.07.003.000	BENZINHAHN KPL.KLEIN RALLYE'96	FUEL COCK CPL. SMALL RALLYE'96	1
6	550.07.006.200	O-RING 11X1,8 NBR 70	O-RING 11X1,8 NBR 70	2
8	590.07.008.044	TANKVERSCHLUSS KPL. MIT VENTIL	FILLER CAP CPL. WITH VALVE	1
9	590.07.009.000	DICHTUNG FÜR TANKVERSCHL.HOCH	GASKET FOR FILLER CAP HIGH	1
10	000.50.140.706	STUFENLOSE EINOHRKLEMME 14,0MM	VARIABLE ONE-EAR CLAMP 14,0MM	3
11	580.31.005.000	YDNAC KLAMMER 10128 12MM	CLAMP YDNAC 10128 12MM	3
13*	800.07.113.000/80	BENZINTANK KPL. 7,5 LIT. GELB	FUEL TANK CPL. 7,5 LIT. YELLOW	1
13*	800.07.113.000/73	BENZINTANK KPL. 7,5 LIT BLAU	FUEL TANK CPL. 7,5 LIT BLUE	1
14	503.07.014.000	TANKROLLE 12X26X12 '98	TANK ROLLER 12X26X12 '98	4
15	580.07.015.000	T-STÜCK FÜR BENZINLEITUNG	T-CONNECTOR FOR FUEL LINE	1
16	600.07.016.000	BENZIN-FORMSCHLAUCH 03	FUEL PREFORMED HOSE 03	1
17	544.35.024.001	ND-SCHLAUCH ID 7,5 PER METER	HOSE ID 7,5 PER METER	0,357
18	583.07.016.001	BENZINSCHL. VITON 6X1,5 PER/M	FUEL HOSE VITON 6X1,5 PER/M	0,055
19	0081 500181	SCHRAUBE FÜR KUNSTSTOFF D=5X18	SCREW FOR PLASTIC D=5X18	2
20	0015 060123	SK.BUNDSCHRAUBE M 6X12 SW=8	HH COLLAR SCREW M 6X12 WS=8	4
21*	584.31.082.200	YDNAC-KLAMMER 13,7MM 2000	CLAMP YDNAC 13,7MM 2000	1
22	0014 060203	SK.BUNDSCHRAUBE M 6X20 SW=8	HH COLLAR SCREW M 6X20 WS=8	2
25	0017 060203	EJOT PT SCHRAUBE K60X20 SW=6	EJOT PT SCREW K60X20 WS=6	X
26	0017 060204	EJOT PT SCHRAUBE K60X20AL SW=6	EJOT PT SCREW K60X20 ALU WS=6	X
30	800.07.030.000	NIPPEL FÜR TANKENTLÜFTUNG 04	NIPPLE FOR VENTILATION HOSE 04	1
40*	800.07.040.300	SITZBANK KPL. HUSABERG 2006	SEAT CPL. HUSABERG 2006	1
41*	800.07.040.350	SITZBANKÜBERZUG 06	SEAT COVER 06	1
43*	503.07.011.000	SCHRAUBE SITZBANKB. D=6X23/18	SCREW SEAT FASTENING D=6X23/18	1
44	800.07.044.000	SITZBANKVERSCHLUSS-SCHRAUBE 04	SCREW PLUG FOR SEAT 04	1
46	800.07.046.000	BÜCHSE FÜR SITZBANK 04	BUSHING FOR SEAT 04	1
47	800.07.047.000	SCHMUTZFILTER SITZBANK 04	DIRT-FILTER SEAT 04	1
50*	800.08.150.100/68	SPOILER LINKS BLAU 2006	SPOILER L/S BLUE 2006	1
50*	800.08.151.100/68	SPOILER RECHTS BLAU 2006	SPOILER R/S BLUE 2006	1
52	800.08.052.000	BUNDBÜCHSE 6,2X10X15X2 04	COLLAR BUSHING 6,2X10X15X2 04	2
53	800.08.053.000	GUMMITÜLLE FÜR SPOILER 04	RUBBER GROMMET FOR SPOILER 04	2
99	800.29.099.000	BORDWERKZEUG HUSABERG 04	TOOL SET HUSABERG 04	1

FIG	TEILNR/PARTNR	BEZEICHNUNG	DESCRIPTION	QTY
1*	503.08.001.000/68	SCHEINWERFERMASKE BLAU FE, FS	HEAD LIGHT MASK BLUE 06 FE, FS	1
2*	800.08.007.000/68	STARTNUMMERTAFEL BLAU FS-C	NUMBER PLATE BLUE 2006 FS-C	1
7	503.08.009.050	SCHRAUBE KOTFL.STR.M8X9 SW=17	SCREW FEND.BRACE M8X9 WS=17	1
8	503.08.009.051	MUTTER KOTFL.STR. M8 SW=17	NUT FENDER BRACE M8 WS=17	1
9*	503.08.009.100	KOTFLÜGELSTREBE SCHWARZ '99 FE	FENDER BRACE BLACK '99 FE	1
10*	800.08.010.000/68	KOTFLÜGEL VO. BREIT BLAU FE	FENDER FRONT WIDE BLUE 06 FE	1
11*	800.08.010.100/68	KOTFLÜGEL VO. KURZ BLAU FS	FENDER FRONT SHORT BLUE 06 FS	1
13	800.08.013.000/80	HECKTEIL GELB 04	REAR PART YELLOW 04	1
14*	800.08.015.200	KENNZEICHENTRÄGER KURZ	NUMBER PLATE CARRIER SHORT	X
15	800.08.015.000	NUMMERTAFELTRÄGER 04	NUMBER PLATE CARRIER SHORT 04	1
16	502.11.086.000	MASKENGUMMI '95	MASK RUBBER UFO WP '95	2
19	590.08.019.000	BREMSSCHLAUCHFÜHRUNG 2000	BRAKE HOSE GUIDE 2000	1
20	584.08.009.050	DISTANZBÜCHSE KOTFLÜGEL VORNE	SPACER BUSHING FRONT FENDER	4
38	546.03.048.100	MEHRBEREICHSBLECHMUTTER M6	RANGE CHANGE METAL NUT M6	2
39	722.10.079.000	STÜTZSCHALE	BUCKET	2
40	546.06.010.000	SPRITZSCHUTZ FÜR FILTERKASTEN	SPLASH PROTECT.FOR FILTER BOX	1
41	800.06.011.000	SPRITZSCHUTZ-OBERTEIL 04	SPLASH PROTECTION TOP-PART 04	1
52	503.08.052.000	BUNDBÜCHSE 6X11X16X5 MM	BUSH FOR SPOILER 6X11X16X5 MM	5
53	503.08.053.000	BUNDBÜCHSE 6X11X16X7,5 MM 98	BUSH FOR SPOILER 6X11X16X7,5	1
59	0015 060123	SK.BUNDSCHRAUBE M 6X12 SW=8	HH COLLAR SCREW M 6X12 WS=8	2
60	0015 060163	SK.BUNDSCHRAUBE M 6X16 SW=8	HH COLLAR SCREW M 6X16 WS=8	5
61	0015 060163	SK.BUNDSCHRAUBE M 6X16 SW=8	HH COLLAR SCREW M 6X16 WS=8	1
62	0014 060153	SK.BUNDSCHRAUBE M 6X15 SW=8	HH COLLAR SCREW M 6X15 WS=8	1(2)
63	0014 060203	SK.BUNDSCHRAUBE M 6X20 SW=8	HH COLLAR SCREW M 6X20 WS=8	4
78	0966 050163	LI.SENKSCHRAUBE DIN0966-M 5X16	OVAL HEAD SCREW DIN0966-M 5X16	2
79	400.06.006.000	FASONSCHLEIBE 6MM	WASHER 6MM	2
80	584.12.080.000	RÜCKSTRAHLER ROT LC4 '98 EU+AUS	REFLECTOR RED LC4 '98 EU+AUS	1
81	584.12.080.050	HALTERUNG FÜR RÜCKSTRAHLER	BRACKET FOR REFLECTOR	1
82	0125 050003	UNTERLEGSCHLEIBE DINO125 A 5,3	WASHER DINO125-A 5,3	2
83	0985 050003	SS.MUTTER DIN 985 M5	SELF LOCKING NUT DIN0985-M 5	2
90	584.12.080.100	SEITENSTRAHLER GELB '99 LINKSVERKEHR	REFLECTOR YELLOW '99 LEFT HAND TRAFFIC	2

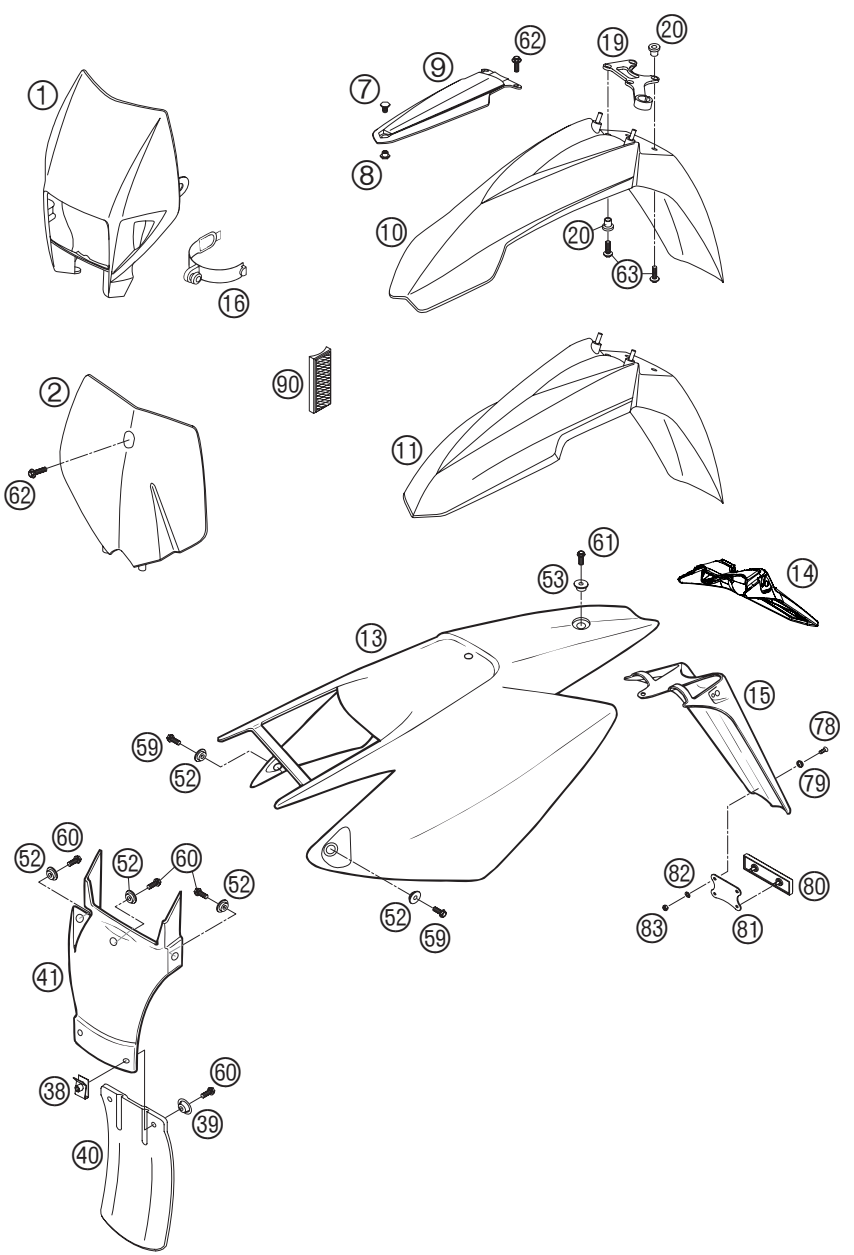
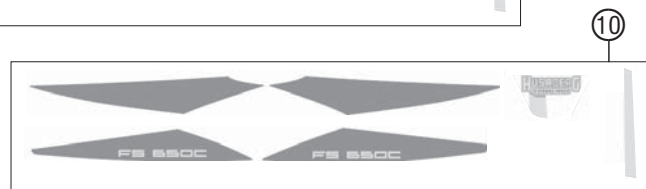
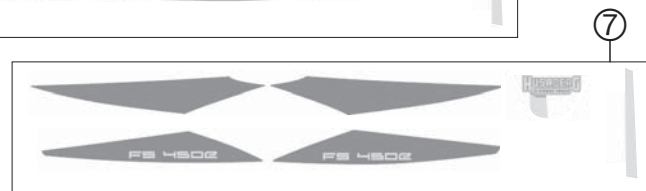
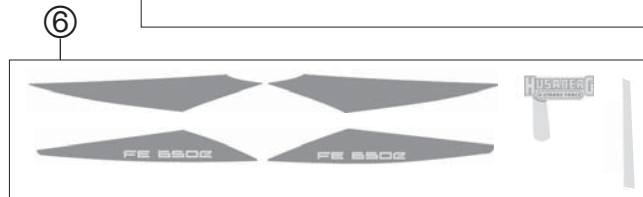
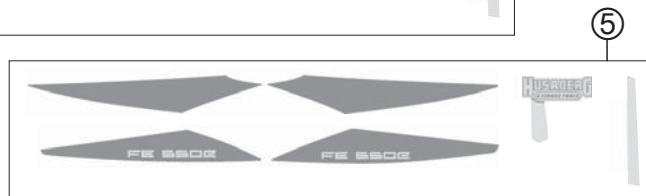
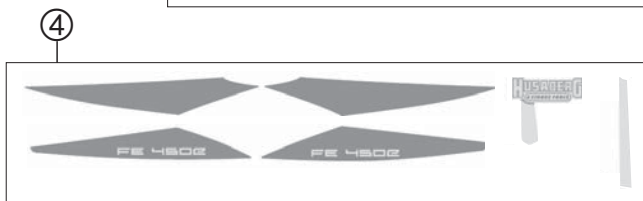



FIG	TEILNR/PARTNR	BEZEICHNUNG	DESCRIPTION	QTY
1*	800.08.090.100	SPOILER DEKOR HUSABERG 06	SPOILER DECAL HUSABERG 06	1
4*	810.08.099.500	DEKORSATZ FE450E 06	DECAL SET FE 450E 06	1
5*	815.08.099.300	DEKORSATZ FE550E 06	DECAL SET FE550E 06	1
6*	820.08.099.300	DEKORSATZ FE650E 06	DECAL SET FE650E 06	1
7*	810.08.099.600	DEKORSATZ FS450E 06	DECAL SET FS 450E 06	1
9*	820.08.099.400	DEKORSATZ FS650E 06	DECAL SET FS650E 06	1
10*	820.08.099.500	DEKORSATZ FS650C 06	DECAL SET FS650C 06	1



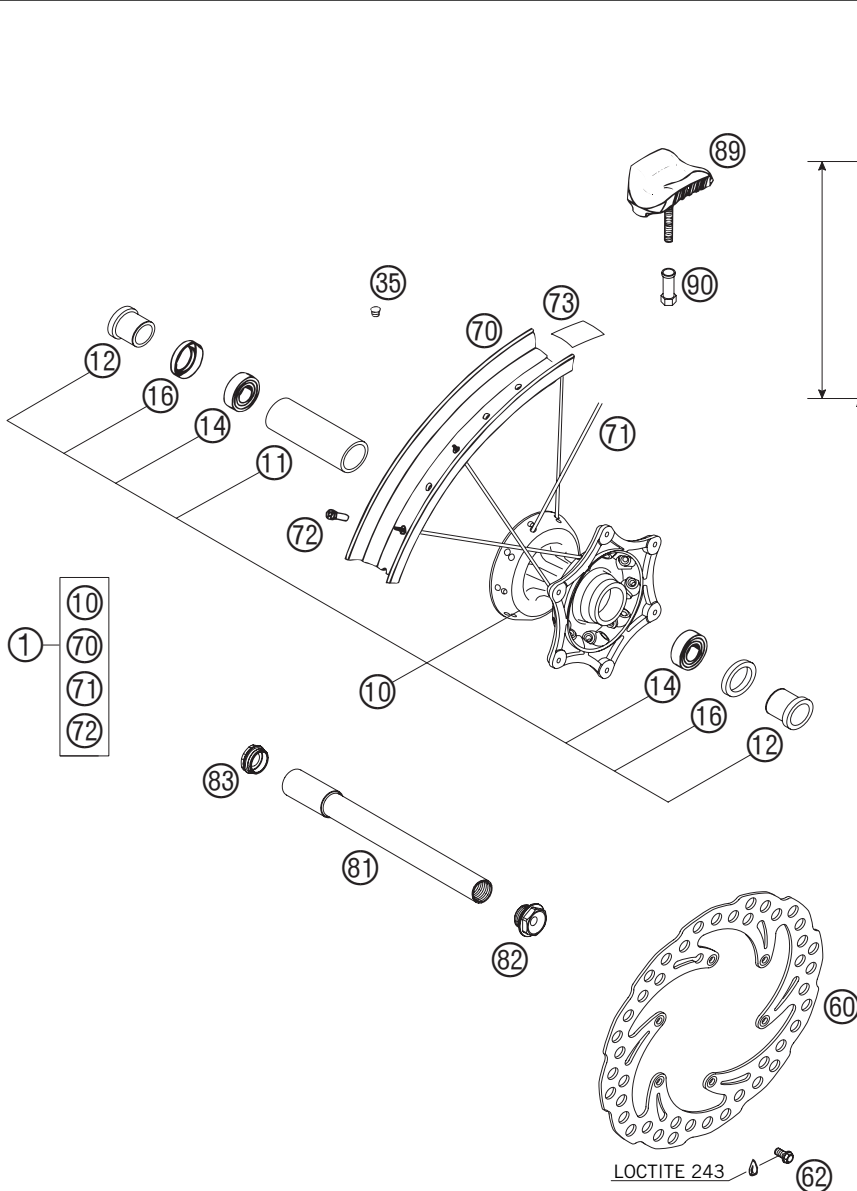

FIG	TEILNR/PARTNR	BEZEICHNUNG	DESCRIPTION	QTY
1	800.09.001.144/91	VORDERRAD KPL. 1,6X21" EXCEL	FRONT WHEEL CPL. 1,6X21" EXCEL	1
10	548.09.010.044/91	VORDERRADNABE KPL. SILBER 03	FRONT HUB CPL. SX SILVER 03	1
11	548.09.011.000	LAGERDISTANZR. 35X2 L=79,4 03	BEA.SPACERTUBE 35X2 L=79,4 03	1
12	548.09.012.000	DISTANZBÜCHSE F. VORDERRAD 03	SPACER BUSHING F. FR. WHEEL 03	2
14	0625 069068	RILLENKUGELL.6906 DDU2CG23S6NM	GR.BALL BEAR.6906 DDU2CG23S6NM	2
16	0760 354771	WELLENDICHTRING 35X47X7 TC	SHAFT SEAL RING 35X47X7 TC	2
35	550.03.135.000	BLINDSTOPFEN FÜR FELGE	PLUG FOR RIM	X
60	548.09.060.100	BREMSSCHEIBE VORNE D=260MM 03	BRAKE DISC FRONT D=260MM 03	1
62	590.09.062.013	SONDERSCHRAUBE M6X13 SW=8 10.9	SPECIAL SCREW M6X13 WS=8 10.9	6
70	546.09.070.100	FELGE VORNE 1,6X21" EXCEL AL4	FRONT RIM 1,6X21" EXCEL AL4	1
71	503.09.072.228	SPEICHE M4,5X228-15G 21" DDE	SPOKE M4,5X228-15G 21" DDE	36
72	503.09.072.000	SPEICHENNIPPEL M4,5X0,75 8X21	SPOKE NIPPLE M4,5X0,75 8X21	36
73	503.09.073.000	FELGENBAND 21"	RIM BAND 21"	1
81	548.09.081.000	STECKACHSE VO. D=26 M24X1,5 03	WHEEL SPIN.FR. D=26 M24X1,5 03	1
82	548.09.082.000	ACHSSCHRAUBE M24X1,5 SW=27 03	SPINDLE SCREW M24X1,5 WS=27 03	1
83	548.09.081.050	VERSCHLUSSBÜCHSE SW=27 03	PLUG BUSHING WS=27 03	1
89	510.09.100.100	REIFENHALTER VM1 (1,60")	RIM LOCK VM1 (1,60")	1
90	503.10.090.050	MUTTER FÜR REIFENHALTER '96	NUT FOR WHEEL HOLDER '96	1

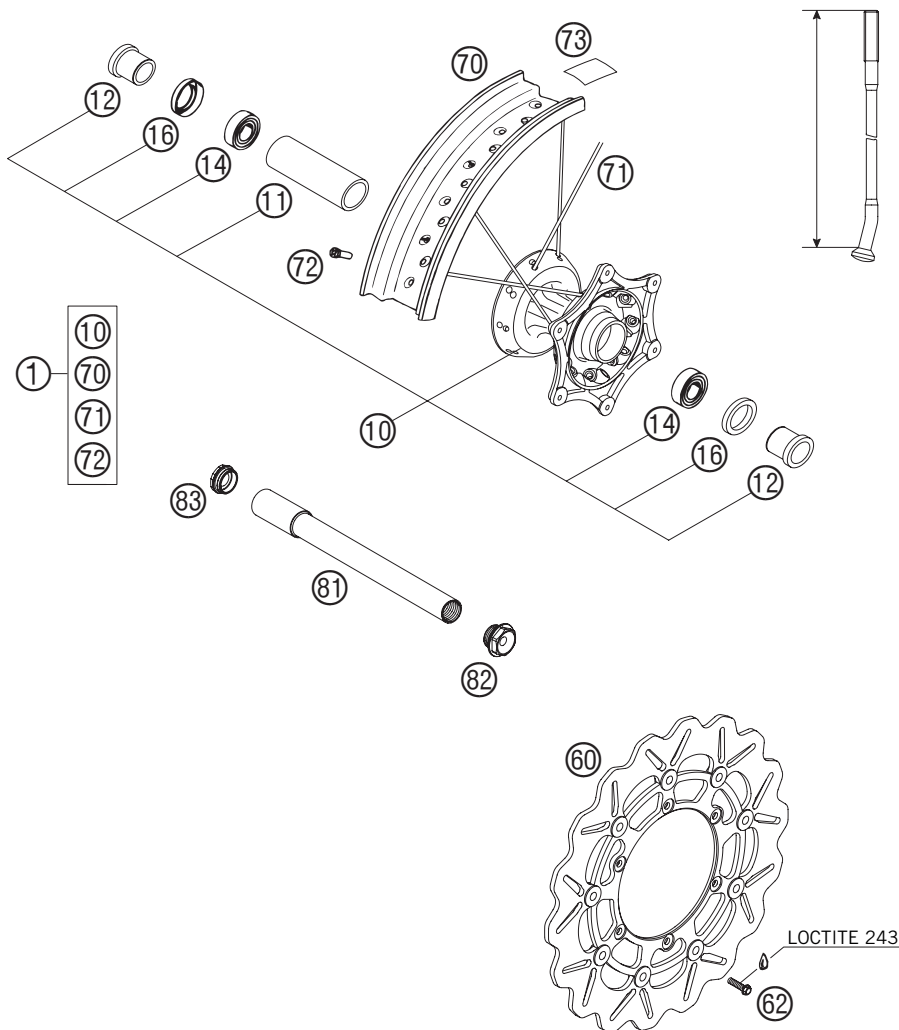

FIG	TEILNR/PARTNR	BEZEICHNUNG	DESCRIPTION	QTY
1	800.09.001.444	VORDERRAD ET 3,5X17" POLIERT05	FRONT WHEEL 3,5X17" POL. 05	1
10	548.09.010.044/91	VORDERRADNABE KPL. SILBER 03	FRONT HUB CPL. SX SILVER 03	1
11	548.09.011.000	LAGERDISTANZR. 35X2 L=79,4 03	BEA.SPACERTUBE 35X2 L=79,4 03	1
12	548.09.012.000	DISTANZBÜCHSE F. VORDERRAD 03	SPACER BUSHING F. FR. WHEEL 03	2
14	0625 069068	RILLENKUGELL.6906 DDU2CG23S6NM	GR.BALL BEAR.6906 DDU2CG23S6NM	2
16	0760 354771	WELLENDICHTRING 35X47X7 TC	SHAFT SEAL RING 35X47X7 TC	2
60	586.09.060.000	BREMSSCHEIBE VO. 2005	BRAKE DISC FRONT 2005	1
62	590.09.062.016	SONDERSCHRAUBE M6X16 SW=8 10.9	SPECIAL SCREW M6X16 WS=8 10.9	6
70	800.09.070.000	FELGE 3,5X17" POLIERT	RIM FRONT 3,5X17" POLISHED	1
71	503.09.071.177	SPEICHE M4,5X177-15G 17" DDE	SPOKE M4,5X177-15G 17" DDE	36
72	503.09.072.000	SPEICHENNIPPEL M4,5X0,75 8X21	SPOKE NIPPLE M4,5X0,75 8X21	36
73	583.09.073.000	FELGENBAND 17"	RIM BAND 17"	1
81	548.09.081.000	STECKACHSE VO. D=26 M24X1,5 03	WHEEL SPIN.FR. D=26 M24X1,5 03	1
82	548.09.082.000	ACHSSCHRAUBE M24X1,5 SW=27 03	SPINDLE SCREW M24X1,5 WS=27 03	1
83	548.09.081.050	VERSCHLUSSBÜCHSE SW=27 03	PLUG BUSHING WS=27 03	1

FIG	TEILNR/PARTNR	BEZEICHNUNG	DESCRIPTION	QTY
1	590.13.015.144	BREMSZANGE VO.KPL.BREMBO 2000	BRAKECALIPER FRONT BREMBO 2000	1
5	546.13.205.000	REP.SATZ 28MM	REPAIR KIT 28MM	1
6	546.13.206.000	REP.SATZ KOLBEN 28MM	REPAIR KIT PISTON 28MM	1
10	590.13.011.000	BREMSSCHL. VO. 1300MM 2000 FE	BRAKEHO. FRONT 1300MM 2000 FE	1
12	546.13.212.000	HALTEBLECHE GARNITUR BREMBO	RETAINING PLATE SET BREMBO	1
18	546.13.218.000	MANSCHETTENSATZ	CUP SET SHORT	1
20	600.13.020.000	ENTLÜFTUNGSSCHRAUBE MIT KAPPE	BLEEDER SCREW WITH CAP	1
21	546.13.210.100	BOLZEN KPL. 6X56	BOLT CPL. 6X56	1
25	502.13.025.000	HOHLSCHRAUBE M10X1X19	HOLLOW SCREW M10X1X19	1
26	420.13.226.000	CU-DICHTRING DIN7603-10X16X1	CU-SEAL RING DIN7603-10X16X1	1
27	420.13.026.000	CU-DICHTRING DIN7603-10X16X1,5	CU-SEAL RING DIN7603-10X16X1,5	1
30	503.13.030.000	GARN.BREMSKL.VO. TOSHIBA H38	BRAKE PAD SET FR. TOSHIBA H38	X
30	546.13.209.044	GARN.BREMSKL.VO. FERODO ID450	BRAKE PAD SET FR. FERODO ID450	X
30	503.13.030.100	GARN.BREMSKL.VO.TOSHIBA TT2701	BRAKE P.SET FR. TOSHIBA TT2701	1
30	590.13.030.000	GARN.BREMSKL.VO. SINTER 03	BRAKE PAT SET FR. SINTER 03	X
35	0015 080353	SK.BUNDSCHRAUBE M 8X35 SW=10	HH COLLAR SCREW M 8X35 WS=10	2

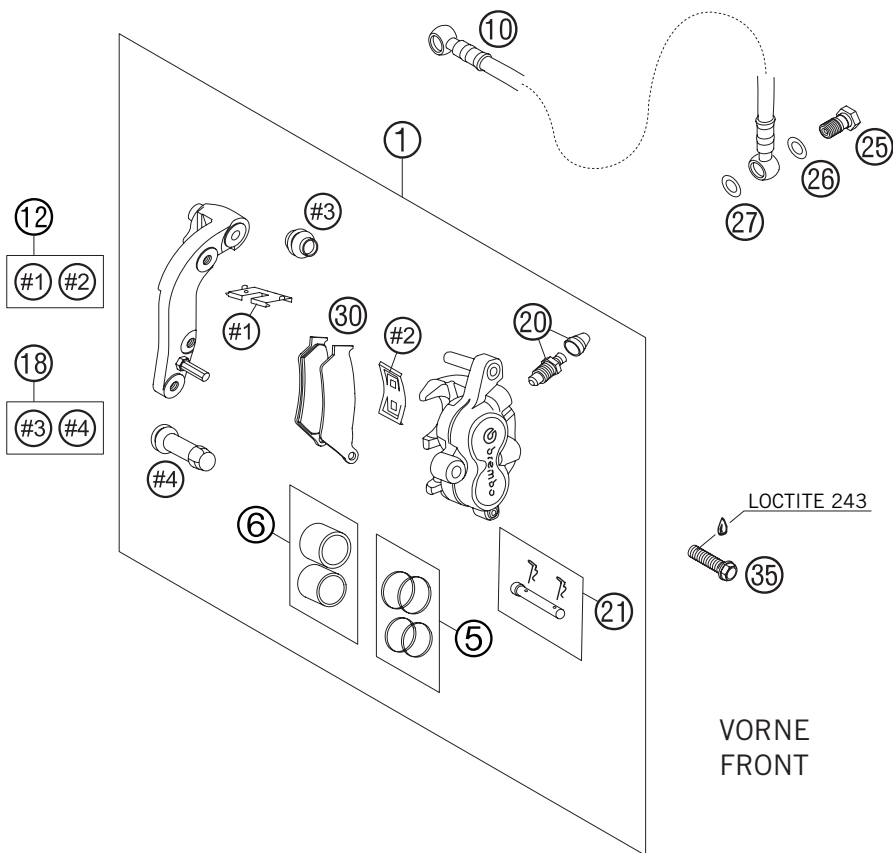
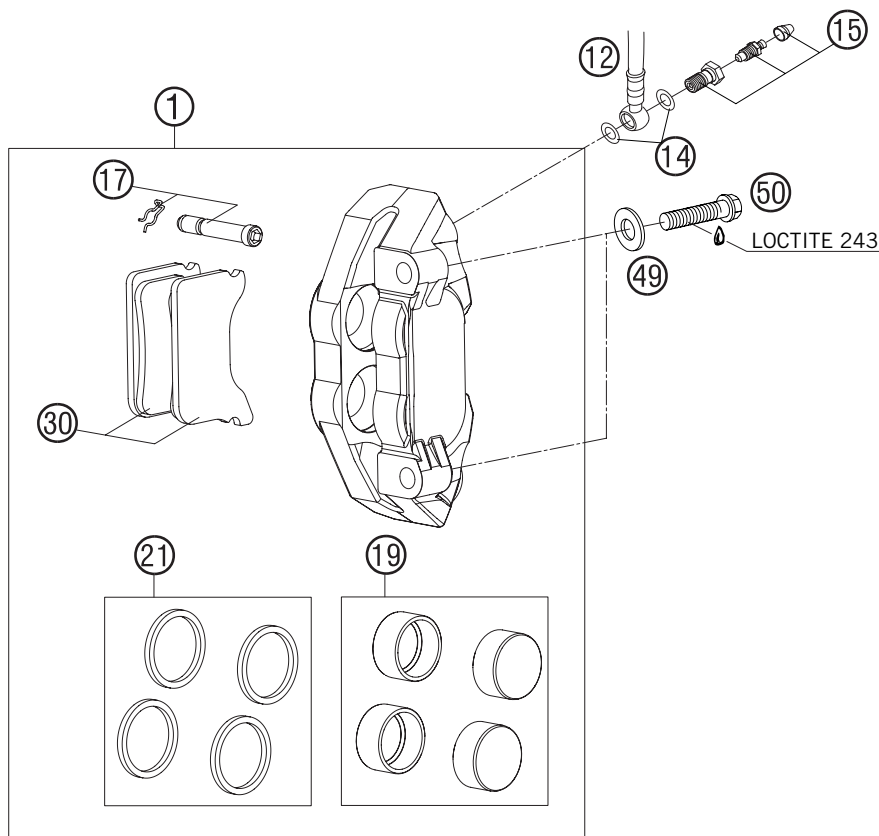

FIG	TEILNR/PARTNR	BEZEICHNUNG	DESCRIPTION	QTY
1*	800.13.015.244	BREMSZANGE VORNE KPL.	BRAKE CALIPER FRONT CPL.	05 1
12	586.13.012.000	BREMSSCHLAUCH 1260MM FS-E	BRAKEHOSE 1260MM FS-E	05 1
12	586.13.012.100	BREMSSCHLAUCH 1175MM FS-C	BRAKEHOSE 1175MM FS-C	05 1
14	0603 100141	CU-DICHTRING DIN7603-10X14X1	COPPER GASKET DIN7603-10X14X1	2
15	586.13.013.000	HOHL-ENTLÜFTUNGSSCHR.KPL.	HOLLOW-BLEEDER SCREW CPL.	05 1
17	586.13.017.000	BOLZEN KPL.	BOLT CPL.	05 1
19	586.13.019.000	KOLBENSATZ KPL.	PISTON KIT CPL.	05 1
21	586.13.021.000	DICHTRING SATZ KPL.	SEAL RING KIT CPL.	05 1
30*	586.13.030.200	GARN.BREMSKL.VO.HS	BRAKE PAD 06	06 1
30*	586.13.030.300	GARN.BREMSKL.VO.RS KEINE STRASSENZULASSUNG	BRAKE PAD 06 WITHOUT STREET-HOMOLOGATION	06 X
49	584.13.049.000	SCHEIBE 10,2X20X2,5 MM	WASHER 10,2X20X2,5 MM	04 2
50	0015 100359	SK.BUNDSCHRAUBE M10X35 SW=13	HH COLLAR SCREW M10X35 WS=13	2



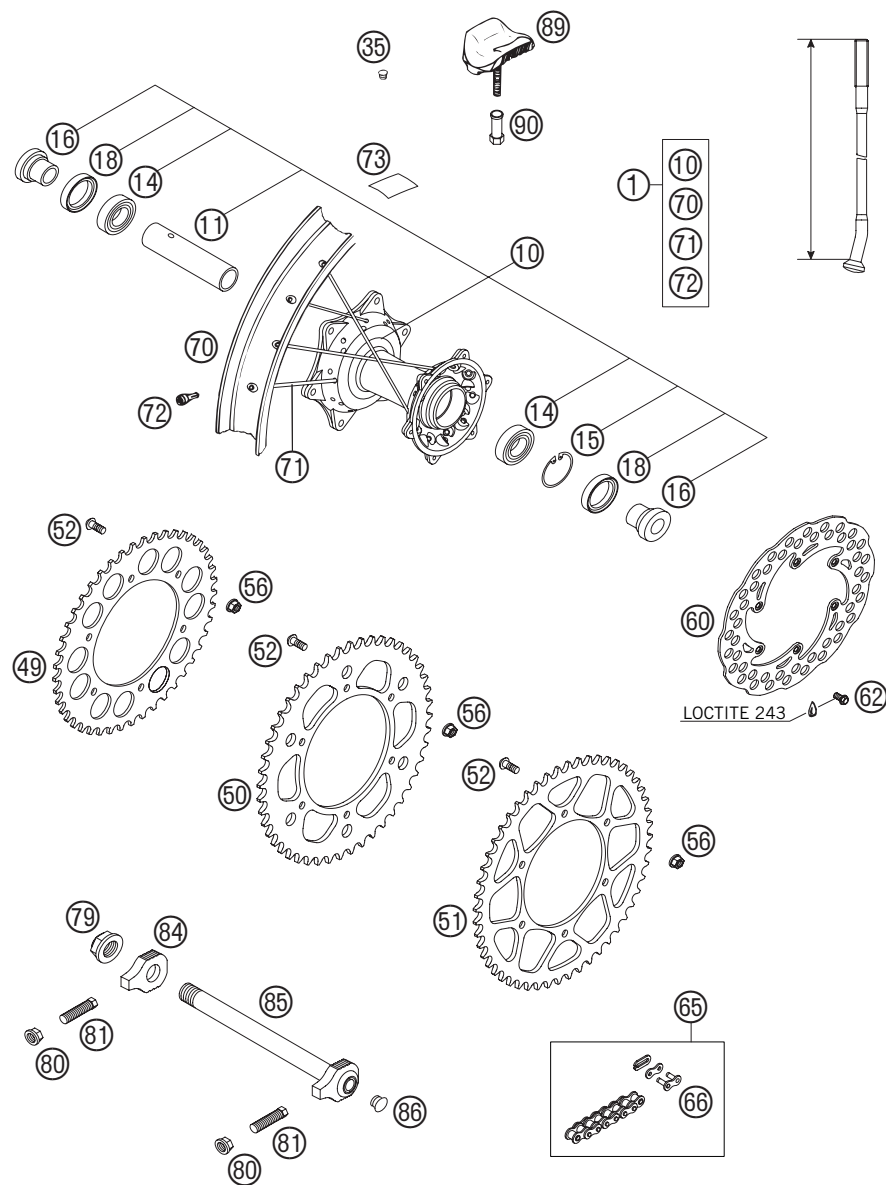
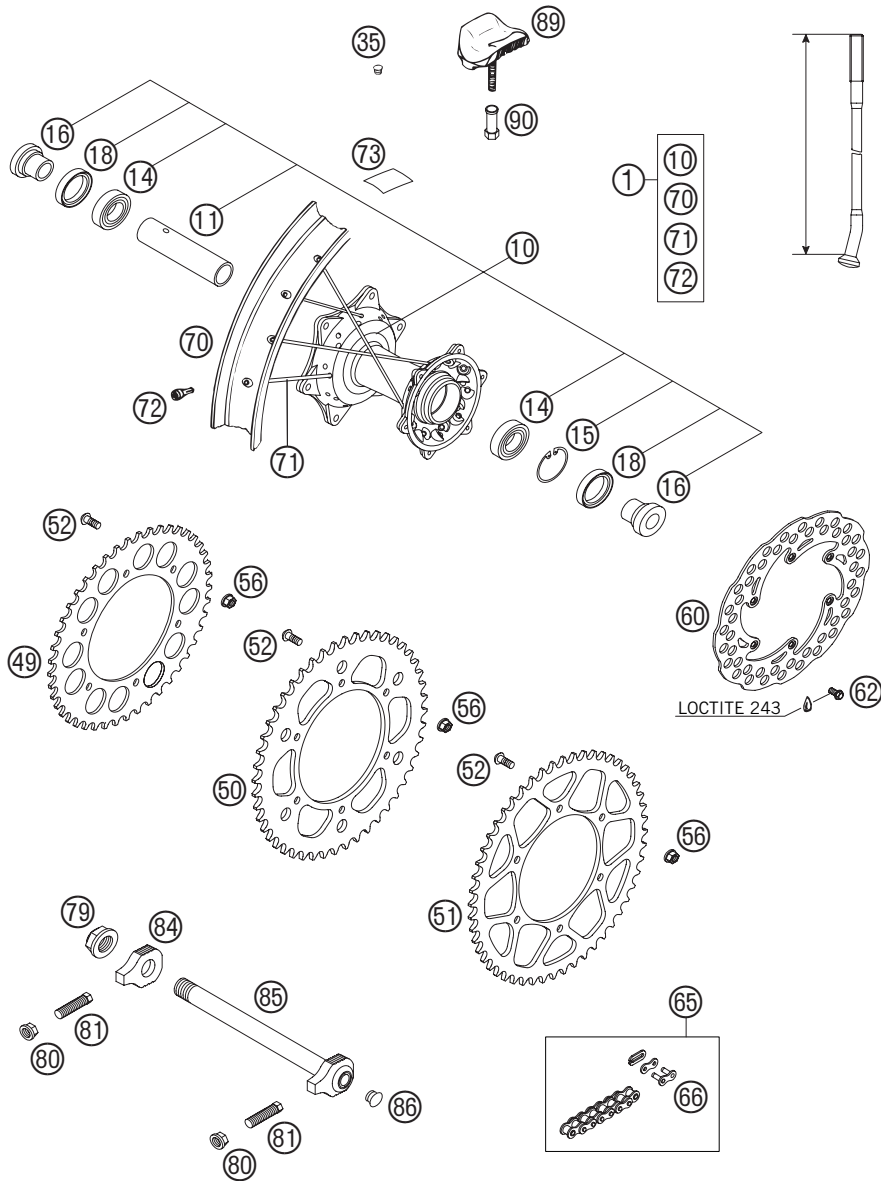

FIG	TEILNR/PARTNR	BEZEICHNUNG	DESCRIPTION	QTY
1	800.10.001.044/91	HINTERRAD KPL. 2,15X18" EXC.04 FE	REAR WHEEL CPL. 2,15X18" EXC. FE	1
10	548.10.010.044/91	HINTERRADNABE KPL. SX, EXC 03	REAR WHEEL HUB CPL. SX, EXC 03	1
11	590.10.011.000	LAGERDistanzROHR 121,5MM 2001	BUSHING SPACER TUBE 121,5MM 01	1
14	0625 060058	RILLENKUGELL.6005 DDU2CG23S6NM	GR.BALL BEAR.6005 DDU2CG23S6NM	2
15	0472 047175	SICHERUNGSRING DIN0472-47X1,75	CIRCLIP DIN0472-47X1,75	1
16	546.10.016.000	BÜCHSE FÜR NABE	BUSHING FOR HUB	2
18	0760 324771	WELLENDICHTRING 32X47X7 BSL	SHAFT SEAL RING 32X47X7 BSL	2
35	550.03.135.000	BLINDSTOPFEN FÜR FELGE	PLUG FOR RIM	X
49	583.10.051.038	KETTENRAD 38-Z	REAR SPROCKET 38-T	X
49	583.10.151.040	KETTENRAD 40-Z	REAR SPROCKET 40-T	X
49	583.10.051.042	KETTENRAD 42-Z	REAR SPROCKET 42-T	X
49	583.10.151.045	KETTENRAD 45-Z	REAR SPROCKET 45-T	X
50	583.10.151.048	KETTENRAD 48-Z	REAR SPROCKET 48-T	X
50	583.10.151.049	KETTENRAD 49-Z	REAR SPROCKET 49-T	X
51	583.10.151.050	KETTENRAD 50-Z	REAR SPROCKET 50-T	X
51	583.10.151.051	KETTENRAD 51-Z	REAR SPROCKET 51-T	X
51	583.10.151.052	KETTENRAD 52-Z	REAR SPROCKET 52-T	X
52	545.10.052.100	KETTENRADSCHR. M8X26 ISK SW=6	SPROCKET SCREW-AH M8X26 WS=6	6
56	543.10.086.200	STOVER-FLANSCHMUTTER M8 10.9	SELF LOCKING NUT M8 10.9	6
60	800.10.060.000	BREMSSCHEIBE 220MM GELOCHT 04	BRAKE DISC REAR PERFORATED 04	1
62	590.09.062.013	SONDERSCHRAUBE M6X13 SW=8 10.9	SPECIAL SCREW M6X13 WS=8 10.9	6
65	800.10.265.118	KETTE 5/8X1/4" + KETTENSCHLOSS	CHAIN 5/8X1/4" + MASTER LINK	1
66	500.10.066.100	KETTENSCHLOSS 5/8X1/4" X-RING	MASTER LINK 5/8X1/4" X-RING	1
70	548.10.070.000	FELGE 2,15X18"EXCEL AL7 SILBER FE	REAR RIM 2,15X18" EXCEL AL7 FE	1
71	503.10.072.195	SPEICHE M5X195-10G 18" DDE FE	SPOKE M5X195-10G 18" DDE FE	36
72	583.09.072.000	SPEICHENNIPPEL M5-TA (8X21MM)	SPOKE NIPPLE M5-TA (8X21MM)	36
73*	503.10.073.200	FELGENBAND 18" UND 19"	RIM BAND 18" AND 19"	1
79	503.10.099.000	SK-MUTTER M20X1,5 '98	HEXAGON NUT M20X1,5 '98	1
80	584.14.030.000	SK-BUNDMUTTER M10X1,25 SW=13	HH COLLAR NUT M10X1,25 WS=13	2
81*	503.04.040.100	SCHRAUBE M10X1,25X50 SW=10	SCREW M10X1,25X50 WS=10	2
84	800.10.084.000	KETTENSANNER RECHTS 04	CHAIN TENSIONER R/S 04	1
85	800.10.085.044	STECKACHSE HINTEN KPL. 04	WHEEL SPINDEL REAR CPL. 04	1

FIG	TEILNR/PARTNR	BEZEICHNUNG	DESCRIPTION	QTY
86	502.10.086.000	ABDECKKAPPE SFL16	COVERING CAP SFL16	1
89	540.10.100.100	REIFENHALTER VM3 (2.15")	RIM LOCK VM3 (2.15")	2(1)
90	503.10.090.050	MUTTER FÜR REIFENHALTER '96	NUT FOR WHEEL HOLDER '96	2(1)



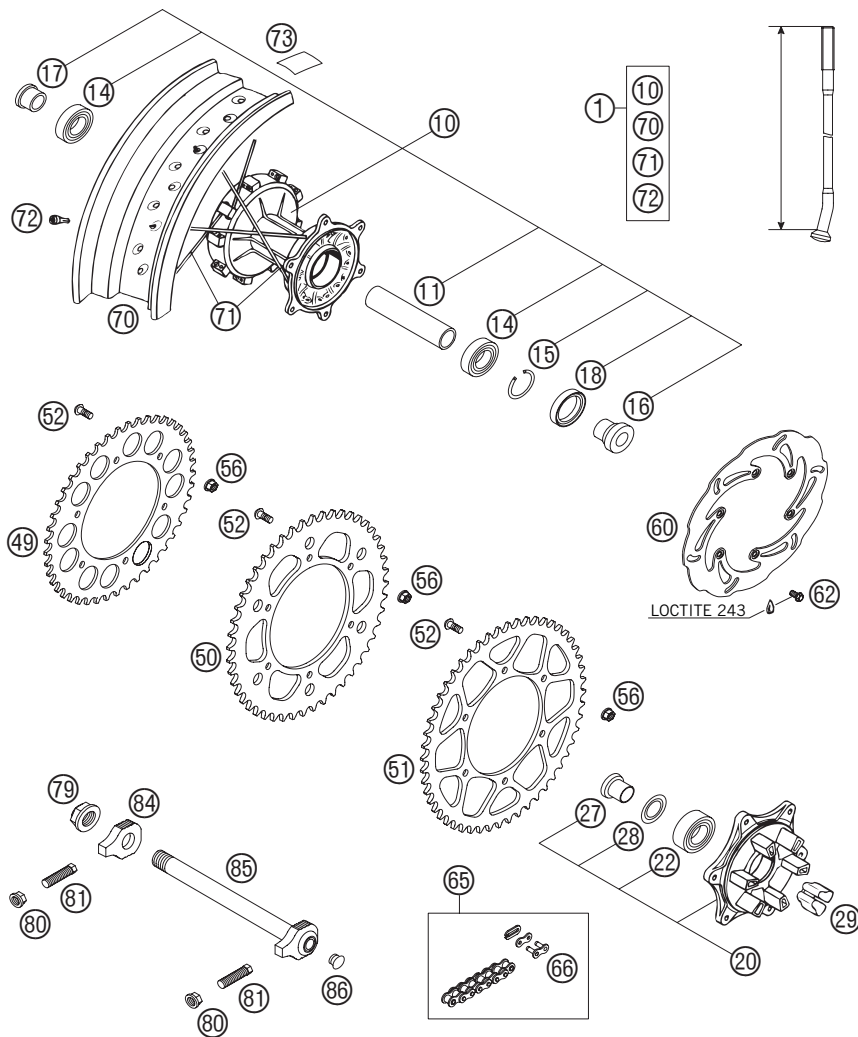

FIG	TEILNR/PARTNR	BEZEICHNUNG	DESCRIPTION	QTY
1*	800.10.001.544	HINTERRAD KPL.GEDÄMP. 4,25X17"	REAR RIM CPL. DAMPED 4,25X17"	1
10*	584.10.010.344/91	RADNABE HINTEN GED. KPL. 06	REAR WHEEL HUB DAMPED CPL. 06	1
11	584.10.011.000	LAGERDISTANZROHR L=98,3MM	BUSHING SPACER TUBE L=98,3MM	1
14	0625 062052	RILLENKUGELL. 6205-2RSHC3HMTF7	GR.BALL BEAR. 6205-2RSHC3HMTF7	2
15	0472 052200	SICHERUNGSRING DIN0472-52X2	CIRCLIP DIN0472-52X2	1
16	584.10.016.000	BÜCHSE FÜR NABE	BUSHING FOR HUB	1
17*	546.10.416.500	BÜCHSE F. HINTERRADNABE GED.06	BUSHING FOR REAR DAMPED HUB 06	1
18	0760 325272	WELLENDICHRING 32X52X7 B	SHAFT SEAL RING 32X52X7 B	1
20*	583.10.050.244	KETTENRADTRÄGER KPL. 05	SPROCKET SUPPORT CPL. 05	1
22*	0625 060058	RILLENKUGELL.6005 DDU2CG23S6NM	GR.BALL BEAR.6005 DDU2CG23S6NM	1
27*	583.10.417.200	BÜCHSE F. KETTENRADTRÄGER 06	BUSH. F.SPROCKETSUPPORT 06	1
28*	583.10.018.000	NILOSRING 6005AV 06	SEAL WASHER 6005AV 06	1
29	546.10.459.000	DÄMPFERGUMMI '91	DAMPING RUBBER '91	6
49	583.10.051.038	KETTENRAD 38-Z	REAR SPROCKET 38-T	X
49	583.10.151.040	KETTENRAD 40-Z	REAR SPROCKET 40-T	X
49	583.10.051.042	KETTENRAD 42-Z	REAR SPROCKET 42-T	X
49	583.10.151.045	KETTENRAD 45-Z	REAR SPROCKET 45-T	X
50	583.10.151.048	KETTENRAD 48-Z	REAR SPROCKET 48-T	X
50	583.10.151.049	KETTENRAD 49-Z	REAR SPROCKET 49-T	X
51	583.10.151.050	KETTENRAD 50-Z	REAR SPROCKET 50-T	X
51	583.10.151.051	KETTENRAD 51-Z	REAR SPROCKET 51-T	X
51	583.10.151.052	KETTENRAD 52-Z	REAR SPROCKET 52-T	X
52	545.10.052.100	KETTENRADSCHR. M8X26 ISK SW=6	SPROCKET SCREW-AH M8X26 WS=6	6
56	543.10.086.200	STOVER-FLANSCHMUTTER M8 10.9	SELF LOCKING NUT M8 10.9	6
60	586.10.060.000	BREMSSCHEIBE 220MM 05	REAR BRAKE DISC 220MM 05	1
62	590.09.062.013	SONDERSCHRAUBE M6X13 SW=8 10.9	SPECIAL SCREW M6X13 WS=8 10.9	6
65	800.10.265.118	KETTE 5/8X1/4" + KETTENSCHLOSS	CHAIN 5/8X1/4" + MASTER LINK	1
66	500.10.066.100	KETTENSCHLOSS 5/8X1/4" X-RING	MASTER LINK 5/8X1/4" X-RING	1
70	584.10.070.000	FELGE 4,25X17" POLIERT	RIM REAR 4,25X17" POLISHED	1
71	583.10.071.100	SPEICHE M5X186-26G 17"	SPOKE M5X186-26G 17"	18
71	583.10.171.100	SPEICHE M5X199-16G 17"	SPOKE M5X199-16G 17"	18
72	583.09.072.000	SPEICHENNIPPEL M5-TA (8X21MM)	SPOKE NIPPLE M5-TA (8X21MM)	36
73	583.09.073.000	FELGENBAND 17"	RIM BAND 17"	1
79	503.10.099.000	SK-MUTTER M20X1,5 '98	HEXAGON NUT M20X1,5 '98	1
80	584.14.030.000	SK-BUNDMUTTER M10X1,25 SW=13	HH COLLAR NUT M10X1,25 WS=13	2
81*	503.04.040.100	SCHRAUBE M10X1,25X50 SW=10	SCREW M10X1,25X50 WS=10	2
84	800.10.084.000	KETTENSCHLUSSEN RECHTS 04	CHAIN TENSIONER R/S 04	1
85	800.10.085.044	STECKACHSE HINTEN KPL. 04	WHEEL SPINDEL REAR CPL. 04	1
86	502.10.086.000	ABDECKKAPPE SFL16	COVERING CAP SFL16	1

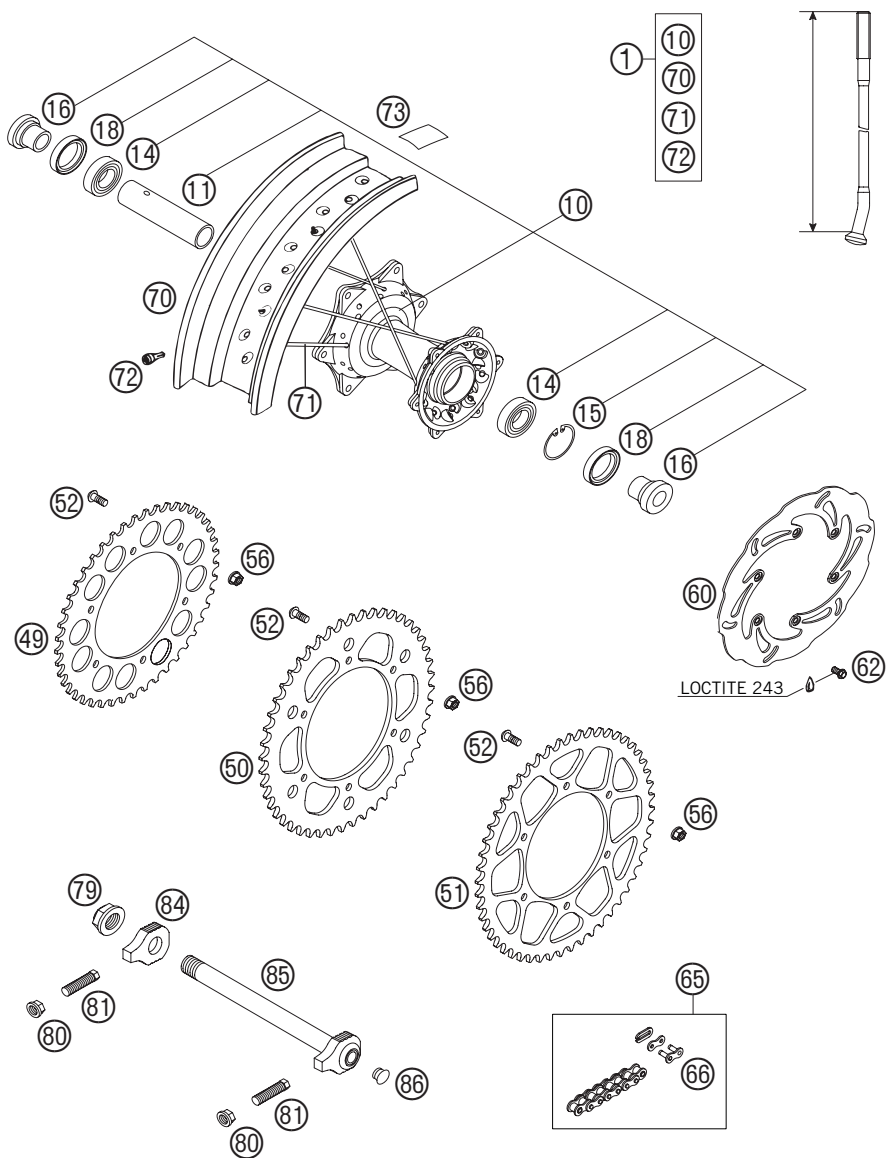

FIG	TEILNR/PARTNR	BEZEICHNUNG	DESCRIPTION	QTY
1	800.10.001.444	HINTERRAD KPL. 5X17"	REAR RIM CPL. 5X17"	1
10	548.10.010.044/91	HINTERRADNABE KPL. SX, EXC 03	REAR WHEEL HUB CPL. SX, EXC 03	1
11	590.10.011.000	LAGERDISTANZROHR 121,5MM 2001	BUSHING SPACER TUBE 121,5MM 01	1
14	0625 060058	RILLENKUGELL.6005 DDU2CG23S6NM	GR.BALL BEAR.6005 DDU2CG23S6NM	2
15	0472 047175	SICHERUNGSRING DIN0472-47X1,75	CIRCLIP DIN0472-47X1,75	1
16	546.10.016.000	BÜCHSE FÜR NABE	BUSHING FOR HUB	2
18	0760 324771	WELLENDICHRING 32X47X7 BSL	SHAFT SEAL RING 32X47X7 BSL	2
49	583.10.051.038	KETTENRAD 38-Z	REAR SPROCKET 38-T	X
49	583.10.151.040	KETTENRAD 40-Z	REAR SPROCKET 40-T	X
49	583.10.051.042	KETTENRAD 42-Z	REAR SPROCKET 42-T	X
49	583.10.151.045	KETTENRAD 45-Z	REAR SPROCKET 45-T	X
50	583.10.151.048	KETTENRAD 48-Z	REAR SPROCKET 48-T	X
50	583.10.151.049	KETTENRAD 49-Z	REAR SPROCKET 49-T	X
51	583.10.151.050	KETTENRAD 50-Z	REAR SPROCKET 50-T	X
51	583.10.151.051	KETTENRAD 51-Z	REAR SPROCKET 51-T	X
51	583.10.151.052	KETTENRAD 52-Z	REAR SPROCKET 52-T	X
52	545.10.052.100	KETTENRADSCHR. M8X26 ISK SW=6	SPROCKET SCREW-AH M8X26 WS=6	6
56	543.10.086.200	STOVER-FLANSCHMUTTER M8 10.9	SELF LOCKING NUT M8 10.9	6
60	586.10.060.000	BREMSSCHEIBE 220MM 05	REAR BRAKE DISC 220MM 05	1
62	590.09.062.013	SONDERSCHRAUBE M6X13 SW=8 10.9	SPECIAL SCREW M6X13 WS=8 10.9	6
65	800.10.265.118	KETTE 5/8X1/4" + KETTENSCHLOSS	CHAIN 5/8X1/4" + MASTER LINK	1
66	500.10.066.100	KETTENSCHLOSS 5/8X1/4" X-RING	MASTER LINK 5/8X1/4" X-RING	1
70	800.10.070.200	FELGE 5X17" POLIERT 05	RIM 5X17" POLISHED 05	1
71	583.10.171.100	SPEICHE M5X199-16G 17"	SPOKE M5X199-16G 17"	36
72	583.09.072.000	SPEICHENNIPPEL M5-TA (8X21MM)	SPOKE NIPPLE M5-TA (8X21MM)	36
73	583.09.073.000	FELGENBAND 17"	RIM BAND 17"	1
79	503.10.099.000	SK-MUTTER M20X1,5 '98	HEXAGON NUT M20X1,5 '98	1
80	584.14.030.000	SK-BUNDMUTTER M10X1,25 SW=13	HH COLLAR NUT M10X1,25 WS=13	2
81*	503.04.040.100	SCHRAUBE M10X1,25X50 SW=10	SCREW M10X1,25X50 WS=10	2
84	800.10.084.000	KETTENSPIANNER RECHTS 04	CHAIN TENSIONER R/S 04	1
85	800.10.085.044	STECKACHSE HINTEN KPL. 04	WHEEL SPINDEL REAR CPL. 04	1
86	502.10.086.000	ABDECKKAPPE SFL16	COVERING CAP SFL16	1

FIG	TEILNR/PARTNR	BEZEICHNUNG	DESCRIPTION	QTY
1	502.13.301.644	BREMSSATTEL KPL. HINTEN LINKS	BRAKE CALIPER CPL. REAR L/S	1
5	546.13.305.200	BREMSKOLBEN 34MM	BRAKE PISTON 34MM	1
6	546.13.318.200	REPSATZ DICHRINGE 34MM	REPAIR KIT SEALING RINGS 34MM	1
10	546.13.310.200	BOLZENSATZ	BOLT SET	1
18	546.13.218.000	MANSCHETTENSATZ	CUP SET SHORT	1
20	600.13.020.000	ENTLÜFTUNGSSCHRAUBE MIT KAPPE	BLEEDER SCREW WITH CAP	1
25	502.13.025.000	HOHLSCHRAUBE M10X1X19	HOLLOW SCREW M10X1X19	1
26	420.13.226.000	CU-DICHRING DIN7603-10X16X1	CU-SEAL RING DIN7603-10X16X1	1
27	420.13.026.000	CU-DICHRING DIN7603-10X16X1,5	CU-SEAL RING DIN7603-10X16X1,5	1
70	800.13.070.000	BREMSSCHLAUCH HINTEN 695MM 04	BRAKE HOSE REAR 695MM 04	1
90	546.13.309.200	GARN.BREMSKL. HI. ID450	BRAKE PAD SET REAR ID450	1
90	503.13.090.000	GARN.BREMSKL. HI. TOSHIBA H38	BRAKE PAD SET REAR TOSHIBA H38	X
90	590.13.090.000	GARN.BREMSKL. HI. SINTER 03	BRAKE PAD SET REAR SINTER 03	X

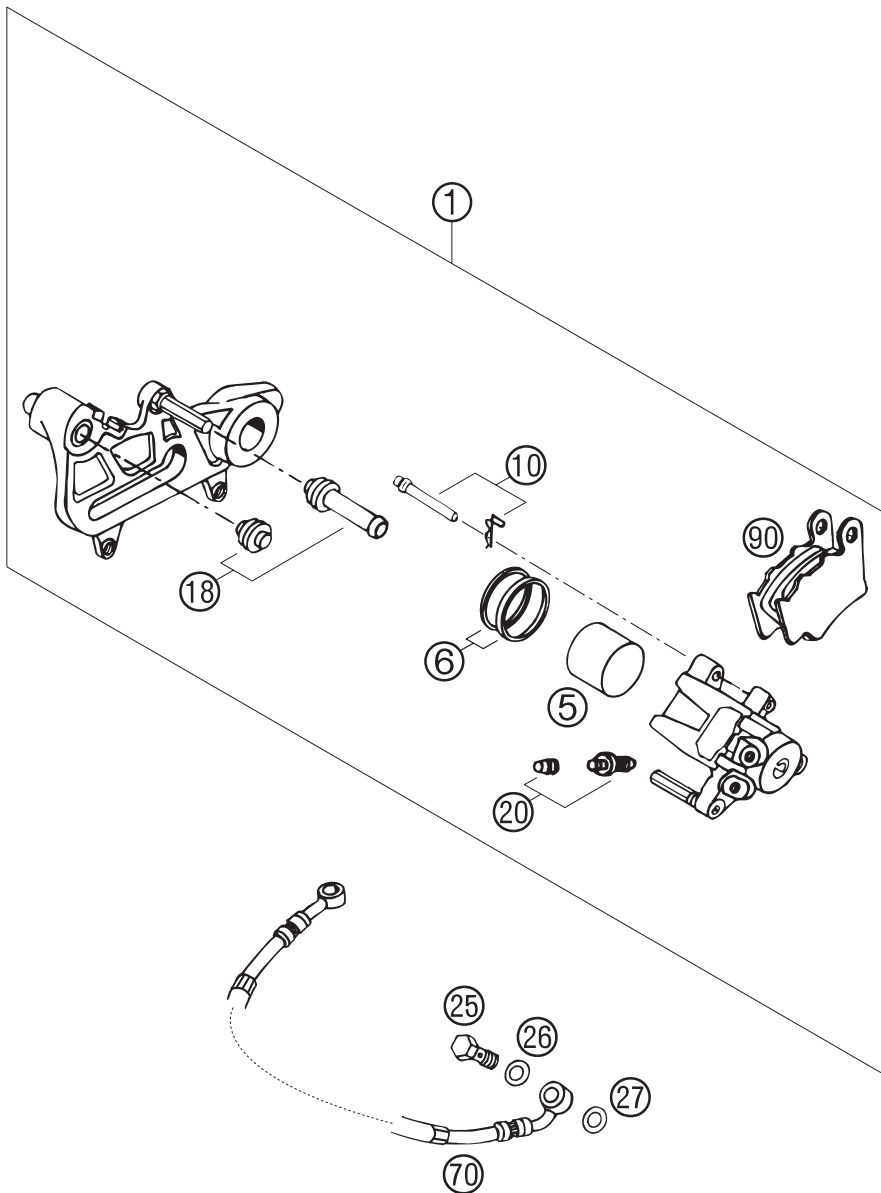
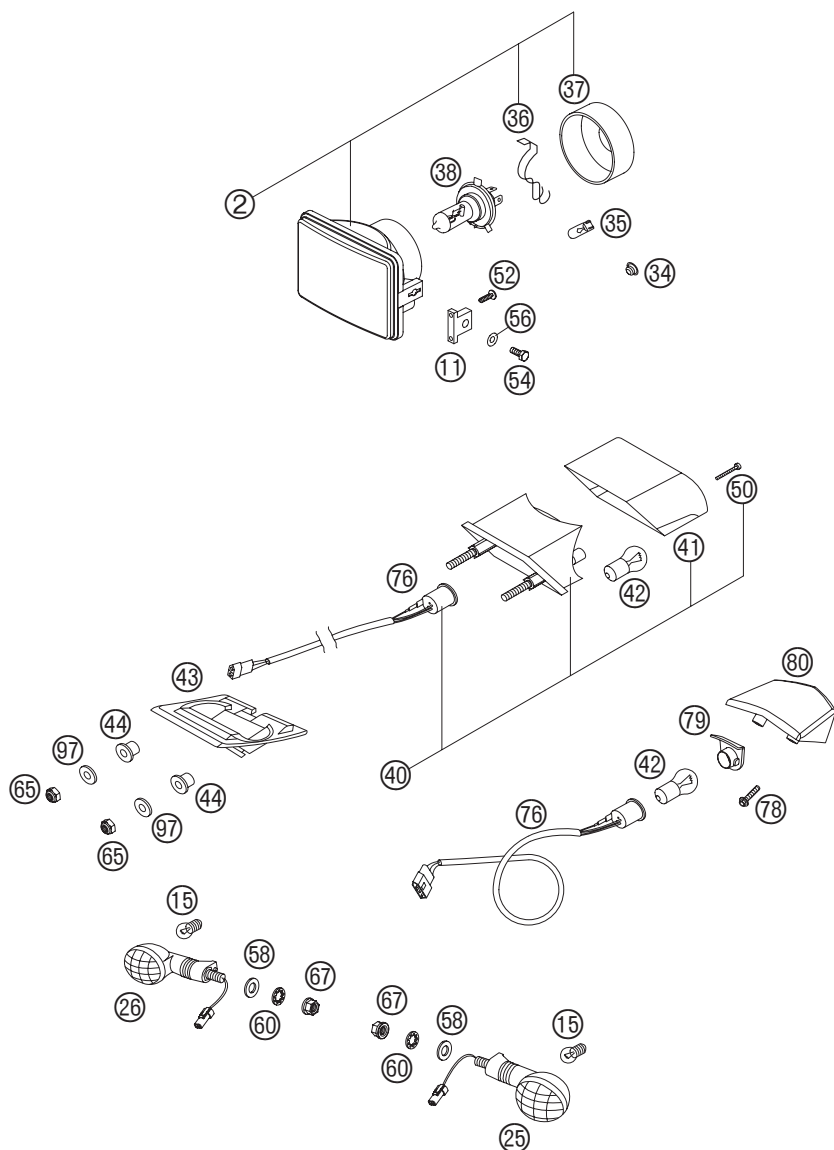
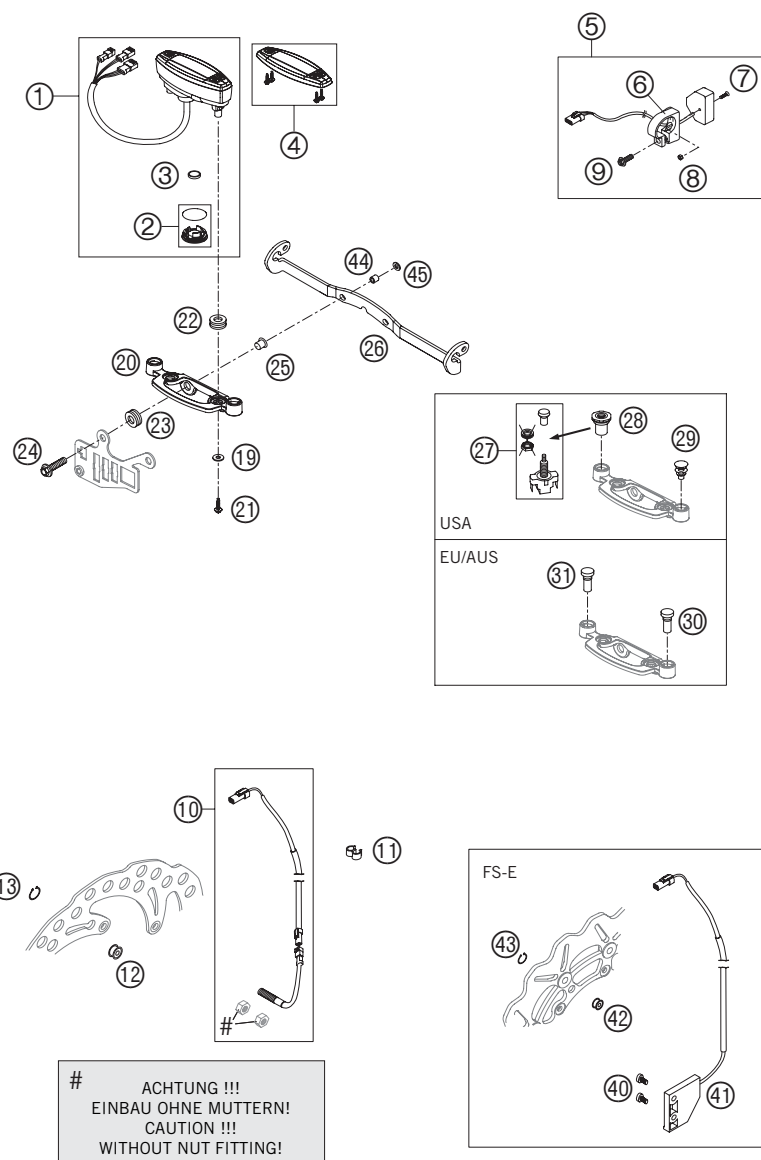

FIG	TEILNR/PARTNR	BEZEICHNUNG	DESCRIPTION	QTY
2	590.14.002.000	SCHEINWERF.186(RE)"1003202 R" RECHTSVERKEHR	HEAD LIGHT 186(RI)"1003202 R" RIGHT HAND TRAFFIC	1
2	590.14.002.100	SCHEINWERF.186(LI)"1003203 L" LINKSVERKEHR	HEAD LIGHT 186(LE)"1003203 L" LEFT HAND TRAFFIC	1
11	584.14.010.100	SCHEINWERFERHALTERUNG 2001	HEAD LIGHT SUPPORT 2001	2
15	441.11.015.100	LAMPE 12V 10W (BA15S)	BULB 12V 10W (BA15S)	4
25*	548.14.025.100	BLINKER KPL.VO.LI./HI.RE. 06	FLASHER CPL.FRONT L/S REAR R/S	2
26*	548.14.026.100	BLINKER KPL. VO.RE./HI.LI. 06	FLASHER CPL. FRONT R/S REAR L/S	2
34	502.10.086.000	ABDECKKAPPE SFL16	COVERING CAP SFL16	1
35*	490.11.435.100	LAMPE 12V 5W (W2,1X9,5D) PHIL.	BULB 12V 5W (W2,1X9,5D) PHIL.	1
36	490.11.436.100	LAMPENHALTESPANGE	BULB HOLDER	1
37	502.11.537.000	GUMMIKAPPE	RUBBER CAP	1
38	546.11.038.012	LAMPE HS1 12V 35/35W WEISS	BULB HS1 12V 35/35W WHITE	1
40	503.14.040.100	RÜCKLICHT KPL. 125-380 EGS '98	REAR LIGHT CPL.125-380 EGS '98	1
41	503.14.041.100	LEUCHTHAUBE 125-380 EGS '98	REAR LIGHT LENS 125-380 EGS'98	1
42	584.14.042.000	LAMPE 12V 21/5W (BAY15S)VERST.	BULB 12V 21/5W (BAY15S)REINFO.	1
43	800.14.043.000	GUMMI RÜCKLICHTBEFESTIGUNG 04	RUBBER REAR LIGHT SUPPORT 04	1
44	800.08.052.000	BUNDBÜCHSE 6,2X10X15X2 04	COLLAR BUSHING 6,2X10X15X2 04	2
50	0981 350323	LI.BLECHSCHR. DIN7981- 3,5X32	SHEET MET. SCR. DIN7981 3,5X32	2
52	0016 040183	SCHRAUBE FÜR KUNSTSTOFF D=4X18	SCREW FOR PLASTIC D=4X18	4
54	0933 060203	SK.SCHRAUBE DIN 933 M6X20	HH SCREW DIN0933-M 6X20	2
56	0125 060003	UNTERLEGSCHIBE DIN0125 A 6,4	WASHER DINO125-A 6,4	2
58	0125 100003	UNTERLEGSCHIBE DIN0125 A 10,5	WASHER DINO125-A10,5	4
60	0797 100003	ZAHNSCHIBE DIN6797-J10,5 ZI	LOCK WASHER DIN6797-J10,5 ZI	4
65	0985 060003	SS.MUTTER DIN0985-M 6	SELF LOCK. NUT DIN0985-M 6	2
67	584.14.030.000	SK-BUNDMUTTER M10X1,25 SW=13	HH COLLAR NUT M10X1,25 WS=13	4
76	503.11.076.000	KABELSTR.HINTERTEIL 125-380'98	WIRING HARNESS REAR 125-380'98	1
97	510.06.097.000	SCHEIBE 6,2X22X1,ST30,W.VERZ.	WASHER 6,2X22X1,ST30,W.GALV.	2
78*	0017 060203	EJOT PT SCHRAUBE K60X20 SW=6	EJOT PT SCREW K60X20 WS=6	2
79*	548.11.076.050	LAMPEN-HALTERUNG 04	LAMP HOLDER 04	1
80*	503.14.041.200	LEUCHTHAUBE 04	REAR LIGHT LENS 04	1





ACHTUNG !!!
 EINBAU OHNE MUTTERN!
 CAUTION !!!
 WITHOUT NUT FITTING!

FIG	TEILNR/PARTNR	BEZEICHNUNG	DESCRIPTION	QTY
1	548.14.069.000	TACHO DIGITAL KM/H F. 21" 2005 UMPROGRAMMIERBAR: KM/H - MPH	SPEEDOMETER KM/H F. 21" 2005 REPROGRAMMABLE: KM/H - MPH	1
1	548.14.069.200	TACHO DIGITAL KM/H F. 17" 2005	SPEEDOMETER KM/H F. 17" 2005	1
2	548.14.069.010	BATTERIEDECKEL F. TACHO 2005	BATTERY COVER F. SPEEDOM. 2005	1
3	583.14.068.000	BATTERIE F.DIG.TACHO M.A.E. 02	BATTERY F. SPEEDOM. M.A.E. 02	1
4	548.14.069.020	OBERTEIL FÜR TACHO 05	SPEEDOMETER TOP PART 05	1
5	548.14.073.000	TRIPMASTER-SCHALTER 05	TRIPMASTER-SWITCH 05	X
6	503.14.068.050	SCHELLE FÜR TRIPM.-SCHALTER 03	CLAMP FOR TRIPMASTER-SWITCH 03	X
7	0965 040125	SENKSCHRAUBE DIN0966-M 4X20	FLAT HEAD SCREW DIN0966-M 4X20	X
8	0934 040003	SK.MUTTER DIN 934 M4	HEXAGON NUT DIN0934-M 4	X
9	0017 060203	EJOT PT SCHRAUBE K60X20 SW=6	EJOT PT SCREW K60X20 WS=6	X
10*	548.14.068.100	GEBERKABEL FÜR DIGITALTACHO 06	CABLE FOR DIGITAL SPEEDOM. 06	1
11	550.11.022.100	ABSTANDHALTER D=6/8MM, SCHWARZ	CLAMP D=6/8MM, BLACK	3
12	548.14.069.050	GEBERMAGNET F. DIGITALTACHO 03	MAGNET FOR DIGITAL SPEEDOM. 03	1
13	0471 009104	SICHERUNGSR.DIN0471- 9X1 INOX	CIRCLIP DIN0471- 9X1 INOX	1
19	0021 050003	SCHEIBE DIN 9021 A 5,3	WASHER DIN9021-A 5,3	2
20	548.14.060.000	TACHOHALTERUNG 05	SPEEDOMETER BRACKET 05	1
21	0016 050121	SCHRAUBE FÜR KUNSTSTOFF D=5X12	SCREW FOR PLASTIC D=5X12	2
22	582.14.069.051	GUMMITÜLLE 16X10,8X3 02	RUBBER GROMMET 16X10,8X3 02	2
23	310.08.060.000	KABELTÜLLE D=8MM OFFEN	RUBBER SLEEVE D=8MM OPEN	2
24	0014 060253	SK.BUNDSCHRAUBE M 6X25 SW=8	HH COLLAR SCREW M 6X25 WS=8	2
24	0015 060303	SK.BUNDSCHRAUBE M 6X30 SW=8 FS-E	HH COLLAR SCREW M 6X30 WS=8 FS-E	2
25	583.14.060.050	DISTANZBÜCHSE F.TACHOHALTERUNG	SPACER BUSH. F. SPEEDOMET.BRA.	2
26	583.14.033.100	BLINKERHALTERUNG 2002	FLASHER BRACKET 2002	1
27	550.11.599.000	ZUGSCHALTER LOSE	PULL SWITCH LOOSE	1
28	548.14.060.050	ZUGSCHALTERMUTTER SW=17	SPEC. NUT F. PULL SWITCH WS=17	1
29	502.10.086.000	ABDECKKAPPE SFL16	COVERING CAP SFL16	1
30	580.11.021.300	FERNLICHTKONTROLLEU. BLAU '98	H.BEAM INDICATOR LIGHT BLUE'98	1
31	580.11.024.300	BLINKERKONTROLLEUCHE GRÜN '98	FLASHER INDICAT.LIGHT GREEN'98	1
40	0084 040083	ZYL.SCHRAUBE DIN 84 A M4X8	CYL.HEAD SCREW DIN0084-M 4X8 A	2
41	800.14.068.100	GEBERKABEL F. TACHO SM 05	CABLE FOR SPEEDOM. SM 05	1
42	800.14.069.150	GEBERMAGNET F. DIGITALTACHO 05	MAGNET FOR DIGITAL SPEEDOM. 05	1
43	0471 100011	SICHERUNGSRING DIN0471-10X1	CIRCLIP DIN0471-10X1	1
44	490.30.090.000	PASSHÜLSE 9,8 X 7 X 10 FS-E	DOWEL 9,8 X 7 X 10 FS-E	2
45	0988 060121	STÜTZSCHEIBE 6X12X1 HRC 40-45 FS-E	WASHER 6X12X1 HRC 40-45 FS-E	2

FIG	TEILNR/PARTNR	BEZEICHNUNG	DESCRIPTION	QTY
1	800.11.075.300	KABELSTRANG FÜR CDI 04/05	IGNITION WIRING HARNESS 04	1
2	800.11.075.400	HAUPTKABELSTRANG FE/FS-USA 05 KPL.	MAIN WIRING FE/FS-USA 05 CPL.	1
3	800.11.079.100	STARTERKABELSTRANG 05	STARTER WIRING HARNESS 05	1
6	503.11.076.000	KABELSTR.HINTERTEIL 125-380'98	WIRING HARNESS REAR 125-380'98	1
9	580.11.109.110	STECKSICHERUNG 10 A 2000	FUSE 10 A 2000	2
10	548.14.060.050	ZUGSCHALTERMUTTER SW=17	SPEC. NUT F. PULL SWITCH WS=17	1
15	0015 060103	SK.BUNDSCHRAUBE M 6X10 SW=8	HH COLLAR SCREW M 6X10 WS=8	1
16	0015 060123	SK.BUNDSCHRAUBE M 6X12 SW=8	HH COLLAR SCREW M 6X12 WS=8	1
23	0014 060203	SK.BUNDSCHRAUBE M 6X20 SW=8	HH COLLAR SCREW M 6X20 WS=8	1
34	800.11.034.000	SPANNUNGSREGLER 04	VOLTAGE REGULATOR 04	1
39	800.11.059.000	STARTERKABEL L=190MM 04 450	STARTER CABLE L=190MM 04 450	1
39	800.11.059.100	STARTERKABEL L=165MM 04 550/650	STARTER CABLE L=165MM 04 550/650	1
40	800.11.059.050	BATTERIEKABEL L=155MM 04	BATTERY CABLE L=155MM 04	1
44	0902 060083	ISK.LI.SCHRAUBE ISO 7380 M 6X8	AH OVAL SCREW ISO 7380 M 6X8	2
46	0985 060003	SS.MUTTER DIN0985-M 6	SELF LOCK. NUT DIN0985-M 6	1
52	410.01.052.000	KABELTÜLLE D=12MM	RUBBER SLEEVE D=12MM	1
53	800.11.053.000	BATTERIE 12V/7AH 04	BATTERY 12V/7AH 04	1
54	800.11.054.000	BATTERIE-BEHÄLTER 04	BATTERY CARRIER 04	1
55	800.11.054.050	DÄMPFUNGSGUMMI 04	DAMPING RUBBER 04	1
56	800.11.056.000	DISTANZBÜCHSE 6MM 04	DISTANCE SPACER 6MM 04	1
57	800.11.058.050	HALBLECH FÜR STARTRELAIS 04	BRACKET FOR STARTER RELAY 04	1
58	582.11.058.000	STARTRELAIS 12V '99	STARTER RELAY 12V '99	1
70	550.11.599.000	ZUGSCHALTER LOSE	PULL SWITCH LOOSE	1
74	594.11.074.000	STARTKNOPF 04	STARTER CONTROL 04	1
76	440.11.076.200	KABELBAND 200/3,6MM SCHWARZ	CABLE TIE 200/3,6MM BLACK	X
76	440.11.076.305	KABELBAND 300/4,8MM SCHWARZ	CABLE TIE 300/4,8MM BLACK	X
86	546.11.186.000	GUMMIBAND	RUBBER BAND	1
89	503.11.089.200	KURZSCHLUSSSCHALTER 02 FE	SHORT CIRCUIT BUTTON 02 FE	1
97	800.11.097.000	MASSEKABEL 04	GROUND CABLE 04	1
99	584.40.099.000	SCHUTZKAPPE F. STARTERMOTOR	PROTECTION CAP F. STARTER ENG.	1

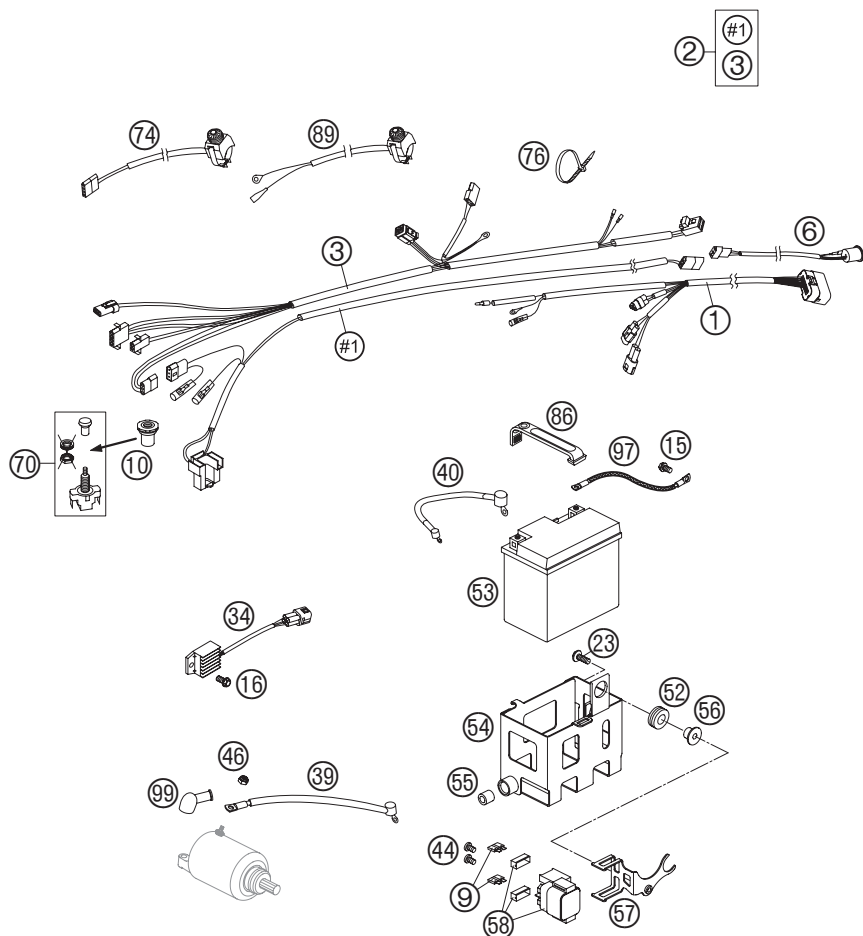

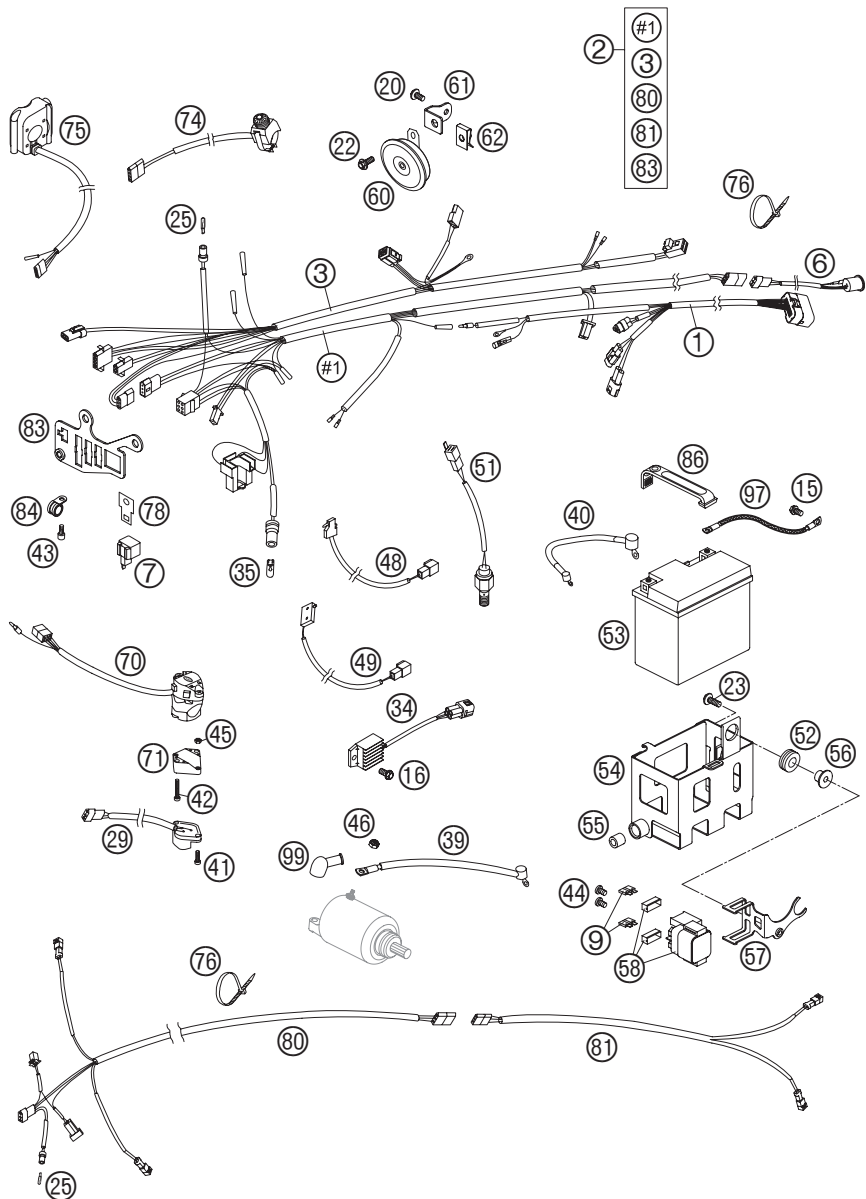

FIG	TEILNR/PARTNR	BEZEICHNUNG	DESCRIPTION	QTY
1	800.11.075.300	KABELSTRANG FÜR CDI 04/05	IGNITION WIRING HARNESS 04	1
2*	800.11.075.600	HAUPTKABELSTR. FE/FS-EU/AUS 06 KPL.	MAIN WIRING FE/FS-EU/AUS 06 CPL.	1
3	800.11.079.100	STARTERKABELSTRANG 05	STARTER WIRING HARNESS 05	1
6	503.11.076.000	KABELSTR.HINTERTEIL 125-380'98	WIRING HARNESS REAR 125-380'98	1
7	446.11.207.200	BLINKGEBER 97	FLASHER UNIT 97	1
9	580.11.109.110	STECKSICHERUNG 10 A 2000	FUSE 10 A 2000	2
15	0015 060103	SK.BUNDSCHRAUBE M 6X10 SW=8	HH COLLAR SCREW M 6X10 WS=8	1
16	0015 060123	SK.BUNDSCHRAUBE M 6X12 SW=8	HH COLLAR SCREW M 6X12 WS=8	1
20	0014 060103	SK.BUNDSCHRAUBE M 6X10 SW=8	HH COLLAR SCREW M 6X10 WS=8	1
22	0014 060153	SK.BUNDSCHRAUBE M 6X15 SW=8	HH COLLAR SCREW M 6X15 WS=8	1
23	0014 060203	SK.BUNDSCHRAUBE M 6X20 SW=8	HH COLLAR SCREW M 6X20 WS=8	1
25	491.11.425.000	LAMPE 12V 1,2W (W2X4,6D)	BULB 12V 1,2W (W2X4,6D)	2
29	503.11.029.000	BLINKERSCHALTER CEV '98	FLASHER SWITCH CEV '98	1
34	800.11.034.000	SPANNUNGSREGLER 04	VOLTAGE REGULATOR 04	1
35*	490.11.435.100	LAMPE 12V 5W (W2,1X9,5D) PHIL.	BULB 12V 5W (W2,1X9,5D) PHIL.	1
39	800.11.059.000	STARTERKABEL L=190MM 04 450	STARTER CABLE L=190MM 04 450	1
39	800.11.059.100	STARTERKABEL L=165MM 04 550/650	STARTER CABLE L=165MM 04 550/650	1
40	800.11.059.050	BATTERIEKABEL L=155MM 04	BATTERY CABLE L=155MM 04	1
41	0985 040163	LINSENSCHRAUBE DIN7985-M 4X16	FLAT HEAD SCREW DIN7985-M 4X16	2
42	0084 040223	ZYL.SCHRAUBE DIN0084-M 4X22 A	CYL.HEAD SCREW DIN0084-M 4X22A	2
43	0912 050083	ISK.SCHRAUBE DIN 912 M 5X8	AH SCREW DIN 912 M 5X8	1
44	0902 060083	ISK.LI.SCHRAUBE ISO 7380 M 6X8	AH OVAL SCREW ISO 7380 M 6X8	2
45	0934 040003	SK.MUTTER DIN 934 M4	HEXAGON NUT DIN0934-M 4	2
46	0985 060003	SS.MUTTER DIN0985-M 6	SELF LOCK. NUT DIN0985-M 6	1
48	503.11.050.100	BREMSLICHTSCHALTER VORNE 2002 FE	BRAKE LIGHT SWITCH FRONT 2002 FE	1
49	586.11.050.000	BREMSLICHTSCHALTER KPL. 05 FS	BRAKE LIGHT SWITCH CPL. 05 FS	1
51	503.11.051.100	BREMSLICHTSCHALTER HINTEN '98	BRAKE LIGHT SWITCH REAR '98	1
52	410.01.052.000	KABELTÜLLE D=12MM	RUBBER SLEEVE D=12MM	1
53	800.11.053.000	BATTERIE 12V/7AH 04	BATTERY 12V/7AH 04	1
54	800.11.054.000	BATTERIE-BEHÄLTER 04	BATTERY CARRIER 04	1

FIG	TEILNR/PARTNR	BEZEICHNUNG	DESCRIPTION	QTY
55	800.11.054.050	DÄMPFUNGSGUMMI 04	DAMPING RUBBER 04	1
56	800.11.056.000	DISTANZBÜCHSE 6MM 04	DISTANCE SPACER 6MM 04	1
57	800.11.058.050	HALBLECH FÜR STARTRELAIS 04	BRACKET FOR STARTER RELAY 04	1
58	582.11.058.000	STARTRELAIS 12V '99	STARTER RELAY 12V '99	1
60	503.11.060.000	GLEICHSTROMHORN 12V K80/L LEB	DC HORN 12V K80/L LEB	1
61	800.11.061.000	HALBLECH FÜR HUPE 04	BRACKET FOR HORN 04	1
		FE	FE	
61	800.11.061.100	HALBLECH FÜR HUPE 05	BRACKET FOR HORN 05	1
		FS	FS	
62	546.03.048.100	MEHRBEREICHSBLECHMUTTER M6	RANGE CHANGE METAL NUT M6	1
70	503.11.070.000	LICHTSCHALTER CEV 98	H.LIGHT SWITCH CEV 2/4TAKT '98	1
71	130.11.070.060	ADAPTER FÜR BLINKERSCHALTER '98	ADAPTER FOR FLASHER SWITCH '98	1
74	594.11.074.000	STARTKNOPF 04	STARTER CONTROL 04	1
75	590.11.074.100	START NOT-AUS SCHALTER 2000	START-STOP SWITCH 2000	1
		GB+AUS	GB+AUS	
76	440.11.076.200	KABELBAND 200/3,6MM SCHWARZ	CABLE TIE 200/3,6MM BLACK	X
76	440.11.076.305	KABELBAND 300/4,8MM SCHWARZ	CABLE TIE 300/4,8MM BLACK	X
78	582.11.031.100	HALBLECH FÜR BLINKRELAIS	BRACKET FOR FLASHER RELAY	1
80*	590.11.080.100	BLINKERKABELSTRANG VORNE 2006	FLASH. WIRINGHARNES FRONT 06	1
81*	800.11.081.000	BLINKER-KABELSTRANG	FLASH. WIRING HARNESS	1
83	548.11.083.100	STECKERBOARD EXC 2005	SUPPORT BRACKET EXC 2005	1
84	570.13.070.100	PVC-SCHELLE 7,9 MM HEYCO 3355	PVC-CLAMP 7,9 MM HEYCO 3355	1
86	546.11.186.000	GUMMIBAND	RUBBER BAND	1
97	800.11.097.000	MASSEKABEL 04	GROUND CABLE 04	1
99	584.40.099.000	SCHUTZKAPPE F. STARTERMOTOR	PROTECTION CAP F. STARTER ENG.	1

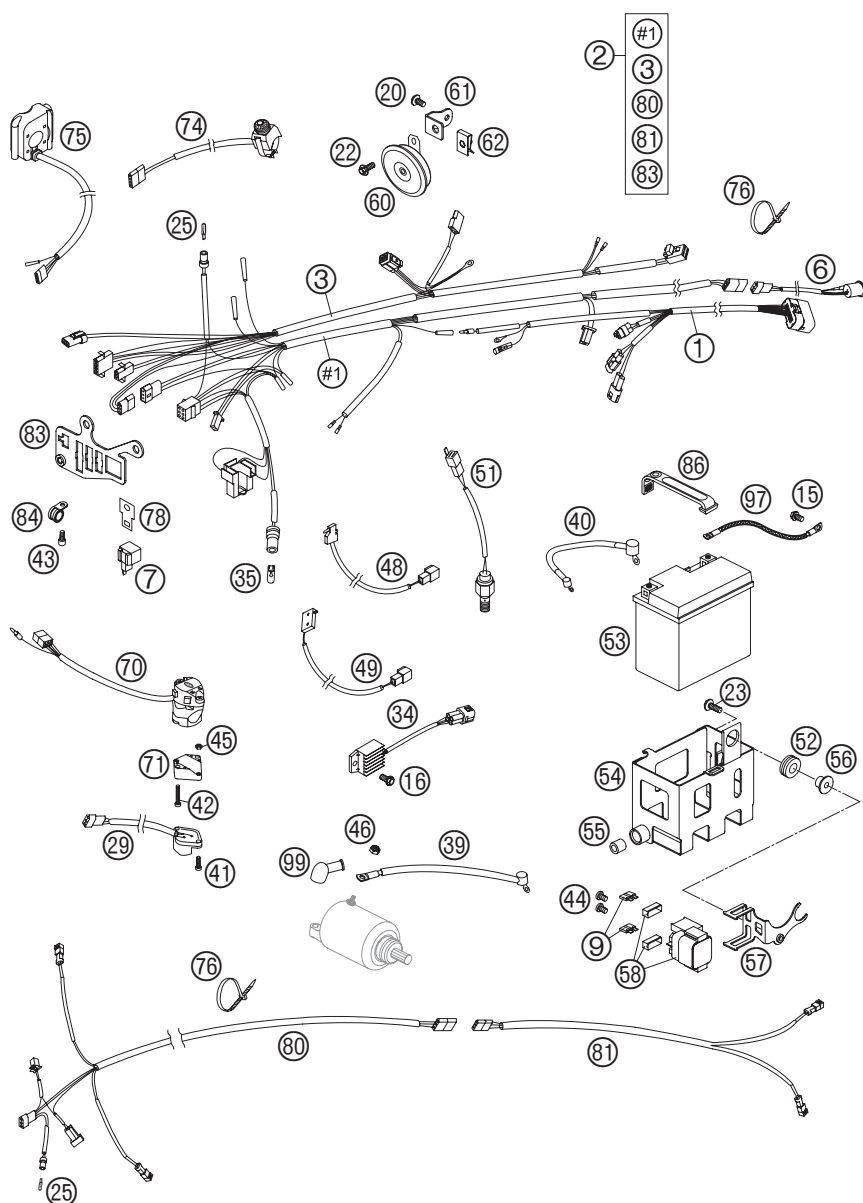
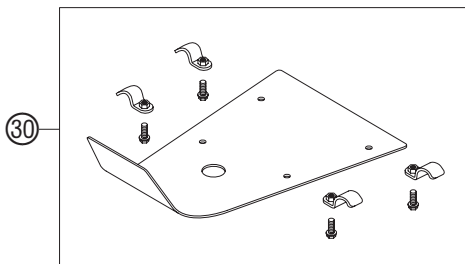
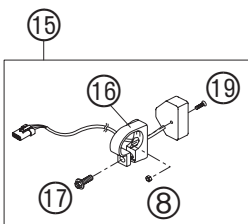
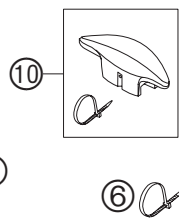
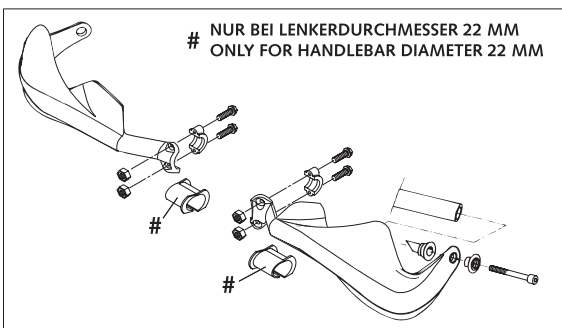
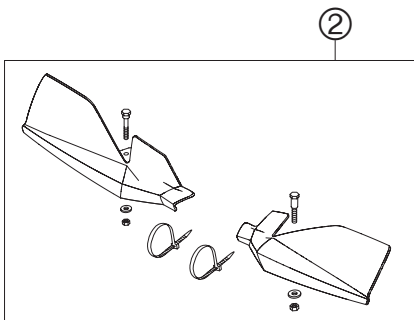
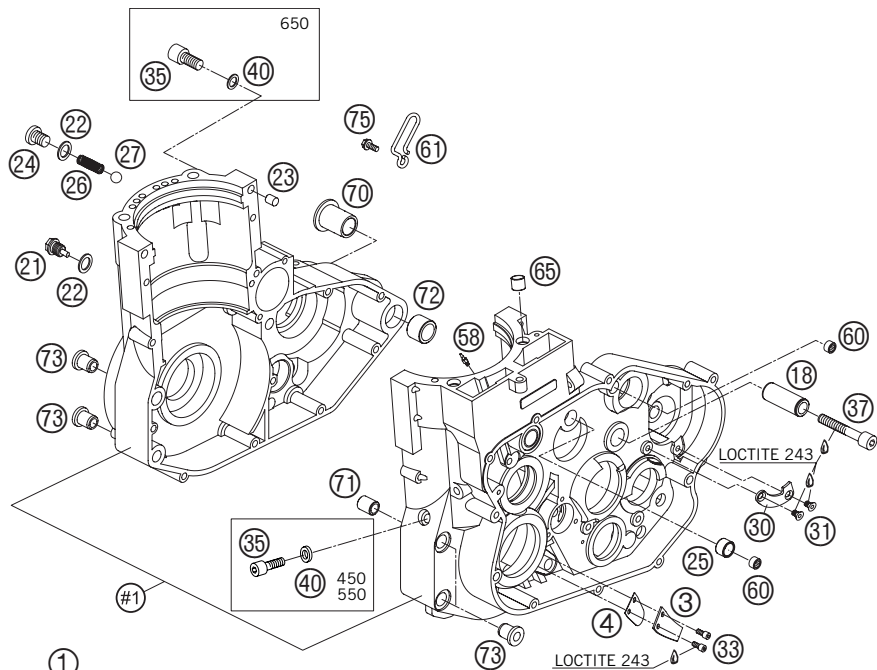

FIG	TEILNR/PARTNR	BEZEICHNUNG	DESCRIPTION	QTY
2*	548.02.079.000/68	HANDSCHUTZ KPL. LI+RE BLAU 06 NICHT FÜR FS	HAND GUARD CPL. L/S+R/S BLUE06 NOT FOR FS	1
2	548.02.079.000/30	HANDSCHUTZ KPL. LI+RE SCHW. 03 NICHT FÜR FS	HAND GUARD CPL. L/S+R/S BLA.03 NOT FOR FS	1
2	548.02.079.000/80	HANDSCHUTZ KPL. LI+RE GELB 04 NICHT FÜR FS	HAND GUARD CPL. 04 NOT FOR FS	1
3	600.02.079.100/30	HANDSCH.LI.U.RE.KPL.SCHWARZ 04	HANDGUARD L/S+R/S CPL.BLACK 04	1
6	800.11.093.200	KABELBAND 200 MM GELB 04	CABLE TIE 200 MM YELLOW 04	X
6	440.11.076.200	KABELBAND 200/3,6MM SCHWARZ	CABLE TIE 200/3,6MM BLACK	X
8	0934 040003	SK.MUTTER DIN 934 M4	HEXAGON NUT DIN0934-M 4	X
10	590.02.002.000	LENKERPOLSTER	HANDLEBAR PAD 05	1
15	548.14.073.000	TRIPMASTER-SCHALTER 05	TRIPMASTER-SWITCH 05	1
16	503.14.068.050	SCHELLE FÜR TRIPM.-SCHALTER 03	CLAMP FOR TRIPMASTER-SWITCH 03	1
17	0017 060203	EJOT PT SCHRAUBE K60X20 SW=6	EJOT PT SCREW K60X20 WS=6	X
19	0965 040125	SENKSCHRAUBE DIN0966-M 4X20	FLAT HEAD SCREW DIN0966-M 4X20	X
30	800.03.090.000	MOTORSCHUTZ ALU 04	ENGINE PROTECTION ALU 04	1





- #1 18 23 25 37 60
71 72 73 65 70
+ 4x 590.30.196.000,
1x 0472 042175, 0015 060103
+ LAGER
BEARINGS
2x 800.30.019.000, 0625 062034,
1x 490.30.023.000, 0625 062054,
0625 068060, 0625 069050

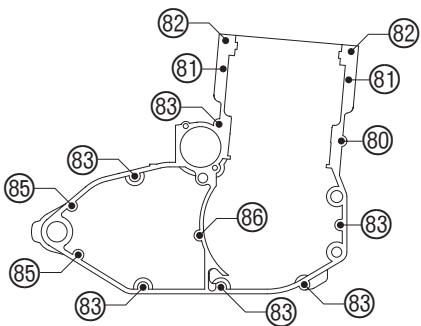
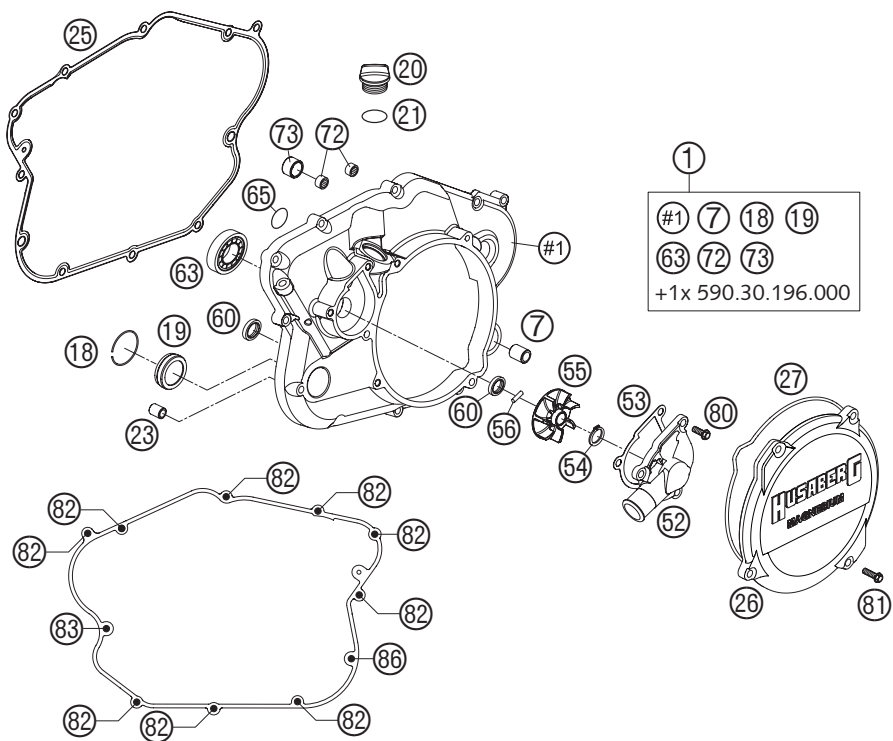

FIG	TEILNR/PARTNR	BEZEICHNUNG	DESCRIPTION	QTY
1	810.30.000.144	MOTORGEHÄUSE KPL. 450	ENGINE CASE CPL. 450	1
1	800.30.000.144	MOTORGEHÄUSE KPL. 550	ENGINE CASE CPL. 550	1
1	820.30.000.144	MOTORGEHÄUSE KPL. 650	ENGINE CASE CPL. 650	1
3	800.30.003.050	ANSCHLAGBLECH MEMBRAN	STOP SHEET MEMBRANE	1
4	800.30.003.051	MEMBRAN	MEMBRANE	1
18	590.33.018.000	LAGERZAPFEN	BUSHING PIN	1
21	580.30.021.000	ÖLABLASSCHR.B.M.MAGNET M 12X1,5	OILDRAIN PLUG W.MAG. M 12X1,5	1
22	580.38.022.000	CU-DICHRING DIN7603-12X18X1,5	CU-SEAL RING DIN7603-12X18X1,5	2
23	590.30.023.000	PASSHÜLSE 6X8X11,5	DOWEL 6X8X11,5	3
24	0908 120153	VERSCHL.SCHR. DIN0908-M12X1,5	PLUG DIN0908-M12X1,5	1
25	800.40.025.050	BUCHSE 12X15X9,7	BUSHING 12X15X9,7	1
26	800.38.026.000	FEDER ÖLDRUCKVENTIL HUSAB.	SPRING OIL PRES.RELIEF HUSA.04	1
27	0401 100000	KUGEL D=10 DIN 5401	BALL D=10 DIN 5401	1
30	800.33.060.000	AUSRÜCKBLECH	ENGAGEMENT SLEDGE	1
31	0019 050103	INNENTORX SENKKOPF M5X10 8.8	INT. TORX FLAT HEAD M 5X10 8.8	2
33	0912 040063	ISK.SCHRAUBE DIN0912-M 4X 6	AH SCREW DIN0912-M 4X 6	2
35	0912 080163	ISK.SCHRAUBE DIN0912-M 8X16	AH SCREW DIN0912-M 8X16	1
37	0912 060404	ISK.SCHRAUBE DIN0912-M 6X40 A2	AH SCREW DIN0912-M 6X40 A2	1
40	580.30.081.000	CU-DICHRING 8 X 14 X 3	CU-SEAL RING 8 X 14 X 3	1
58	800.30.058.060	SPRITZDÜSE "60" M4	OIL JET "60" M4	1
60	800.40.060.000	NADELLAGER HK 0810	NEEDLE BEARING HK 0810	2
61	800.31.081.000	BÜGEL FÜR ENTLÜFTUNGSSCHL.	BOW FOR BREATHER HOSE	1
65	800.36.085.000	PASSBÜCHSE 10,5X12X10	DOWEL 10,5X12X10	2
70	800.30.170.000	PASSBÜCHSE GEHÄUSE HINTEN	DOWEL ENGINE CASE REAR	2
71	800.30.071.000	PASSHÜLSE 9X13X15,5	DOWL 9X13X15,5	1
72	800.30.072.000	PASSHÜLSE 18X22X16	DOWEL 18X22X16	1
73	800.30.171.000	PASSBÜCHSE GEHÄUSE VORNE	DOWEL ENGINE CASE FRONT	4
75	0015 050123	SK.BUNDSCHRAUBE M 5X12 SW=8	HH COLLAR SCREW M 5X12 WS=8	1
80	0015 060353	SK.BUNDSCHRAUBE M 6X35 SW=8	HH COLLAR SCREW M 6X35 WS=8	1
81	0015 060403	SK.BUNDSCHRAUBE M 6X40 SW=8	HH COLLAR SCREW M 6X40 WS=8	2
82	0015 060453	SK.BUNDSCHRAUBE M 6X45 SW=8	HH COLLAR SCREW M 6X45 WS=8	2
83	0015 060503	SK.BUNDSCHRAUBE M 6X50 SW=8	HH COLLAR SCREW M 6X50 WS=8	6
85	0015 060603	SK.BUNDSCHRAUBE M 6X60 SW=8	HH COLLAR SCREW M 6X60 WS=8	2
86	0015 060653	SK.BUNDSCHRAUBE M 6X65 SW=8	HH COLLAR SCREW M 6X65 WS=8	1
99	800.30.099.000	DICHTUNGSSATZ 450-650 HUSAB.04	GASKET SET 450-650 HUSABERG 04	1

FIG	TEILNR/PARTNR	BEZEICHNUNG	DESCRIPTION	QTY
1	800.30.001.044	KUPPLUNGSDECKEL KPL. 04	CLUTCH COVER CPL. 04	1
7	800.34.007.053	GLEITBUCHSE KUNSTSTOFFBESCH.03	SLIDING SLEEVE PLASTIC-COAT 03	1
18	610.30.019.050	SICHERUNGSRING ÖLSCHAUGLAS 05	CIRCLIP OIL LEVEL GLASS 03	1
19	590.30.019.000	ÖLSCHAUGLAS G 1777 Y	OIL LEVEL GLASS G 1777 Y	1
20	580.30.020.000	ÖLEINFÜLLSCHRAUBE M 24X3	PLUG M 24X3	1
21	0770 191015	O-RING 19,00X3,00 NBR	O-RING 19,00X3,00 NBR	1
23	590.30.023.000	PASSHÜLSE 6X8X11,5	DOWEL 6X8X11,5	2
25	800.30.025.000	KUPPLUNGSDECKELDICHTUNG 03	GASKET CLUTCH COVER 03	1
26	800.30.026.000	KUPPLUNGSDECKEL AUSSEN 03	OUTER CLUTCH COVER 03	1
27	800.30.027.100	FORMDICHTRING 05	GASKET OUTER CLUTCH COVER 05	1
52	800.35.052.000	WASSERPUMPENDECKEL 03	WATER PUMP COVER 03	1
53	800.35.053.000	WASSERPUMPENDECKELDICHTUNG 03	GASKET WATER PUMP COVER 03	1
54	0471 100010	SICHERUNGSRING DIN0471-10X1	CIRCLIP DIN0471-10X1	1
55	800.35.055.000	WASSERPUMPENRAD 03	WATER PUMP GEAR 03	1
56	0402 251980	NADELROL. DIN5402 NRA 2,5X19,8	NEEDLEROL.DIN5402 NRA 2,5X19,8	1
60	0760 101843	WELLENDICHTRING 10X18X4 BSL	SHAFT SEAL RING 10X18X4 BSL	2
63	0625 062013	RILLENKUGEL.SONDERL.SKF 6201	BALL BEARING SPEC.B.B.SKF 6201	1
65	0770 173024	O-RING 17,30X2,40 NBR 70 SH	O-RING 17,30X2,40 NBR 70 SH	1
72	800.40.060.000	NADELLAGER HK 0810 03	NEEDLE BEARING HK 0810 03	2
73	800.40.025.050	BUCHSE 12X15X9,7	BUSHING 12X15X9,7	1
80	0015 060163	SK.BUNDSCHRAUBE M 6X16 SW=8	HH COLLAR SCREW M 6X16 WS=8	3
81	0015 060203	SK.BUNDSCHRAUBE M 6X20 SW=8	HH COLLAR SCREW M 6X20 WS=8	4
82	0015 060253	SK.BUNDSCHRAUBE M 6X25 SW=8	HH COLLAR SCREW M 6X25 WS=8	9
83	0015 060303	SK.BUNDSCHRAUBE M 6X30 SW=8	HH COLLAR SCREW M 6X30 WS=8	1
86	0015 060453	SK.BUNDSCHRAUBE M 6X45 SW=8	HH COLLAR SCREW M 6X45 WS=8	1



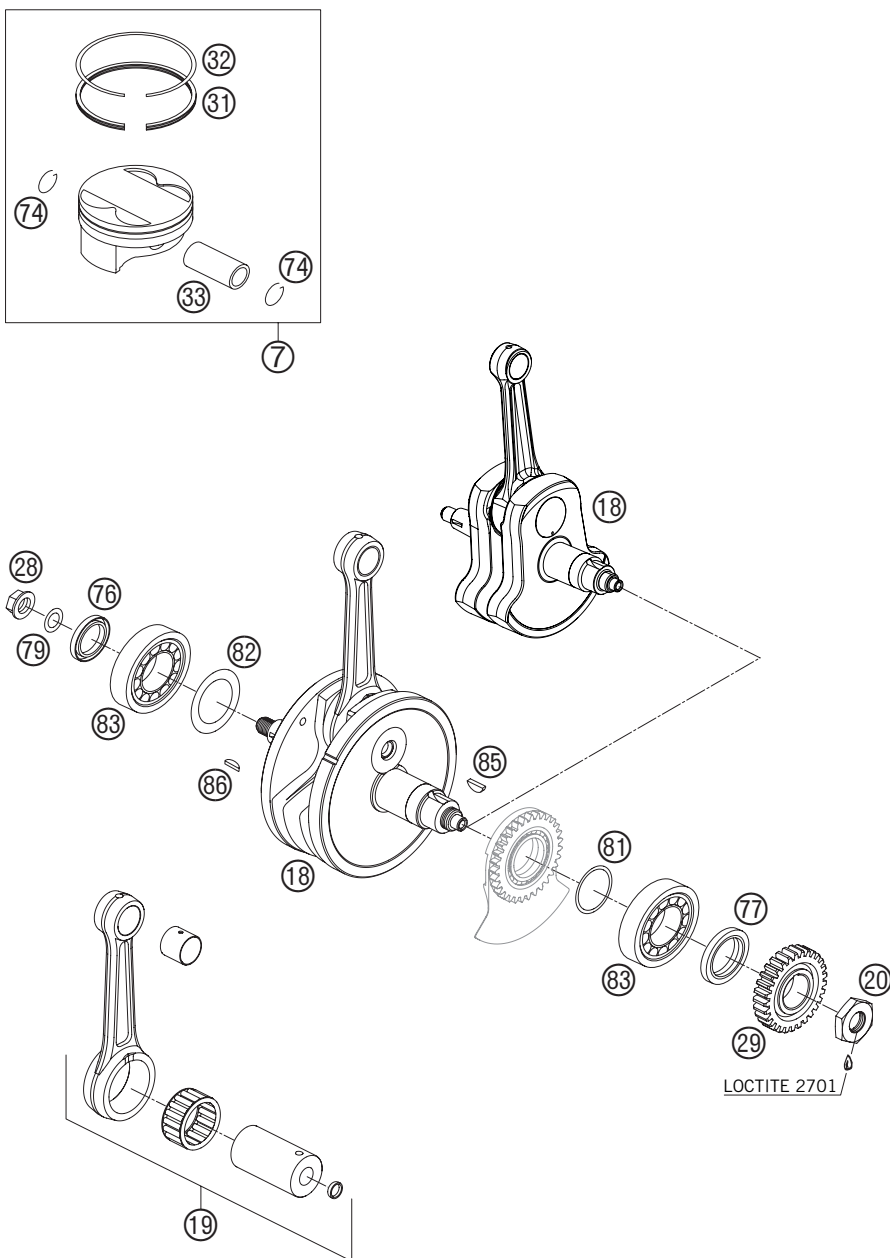

FIG	TEILNR/PARTNR	BEZEICHNUNG	DESCRIPTION	QTY
7	810.30.007.000/ I	KOLBEN I KPL. 100 MM 450 03	PISTON I CPL. 100 MM 450 03	1
7	810.30.007.000/ II	KOLBEN II KPL. 100 MM 450 03	PISTON II CPL. 100 MM 450 03	1
7	815.30.007.000/ I	KOLBEN I KPL. 100 MM 550 03	PISTON I CPL. 100 MM 550 03	1
7	815.30.007.000/ II	KOLBEN II KPL. 100 MM 550 03	PISTON II CPL. 100 MM 550 03	1
7*	820.30.007.100/ I	KOLBEN 650 06	PISTON 650 06	1
7*	820.30.007.100/ II	KOLBEN 650 06	PISTON 650 06	1
18	810.30.018.100	KURBELWELLE 450 FE KPL. 05 FS-E	CRANKSHAFT 450 FE CPL. 05 FS-E	1
18	815.30.018.000	KURBELWELLE 550 FE, FS KPL. 03	CRANKSHAFT 550 FE, FS CPL. 03	1
18	820.30.018.100	KURBELWELLE 650 FE KPL. 05	CRANKSHAFT 650 FE CPL. 05	1
19	810.30.015.100	PLEUEL-REP.SATZ 450 05	CONROD REP. KIT 450 05	1
19	800.30.015.000	PLEUEL-REP.SATZ 501/550 03	CONROD REP.KIT 501/550 03	1
19	820.30.015.100	PLEUEL-REP.SATZ 650 05	CONROD REP. KIT 650 05	1
20	800.30.018.020	MUTTER M16X1 SW=30 03	NUT M16X1 WS=30 03	1
28	510.30.028.100	BUNDMUTTER M12X1 LINKS SW=17	COLLAR NUT M12X1 LEFT WS=17	1
29	800.32.000.029	PRIMÄRRAD 29-Z 03	PRIMARY GEAR 29-T 03	1
31	600.30.032.000	ÖLABSTREIFRING D=100MM 03	OIL SCRAPER RING D=100MM 03	1
32	800.30.032.000	RECHTECKRING 100X1,25	RECTANGULAR RING 100X1,25	1
33	590.30.033.000	KOLBENBOLZEN 20X15,8/12X50	PISTON PIN BOLT 20X15,8/12X50	1
74	590.30.074.000	DRAHTSPRENGRING C20X1,5 450/550	CIRCLIP C20X1,5 450/550	2
74*	820.30.074.000	DRAHTSPRENGRING 20X1,5 650	CIRCLIP 20X1,5 650	2
76	0760 254071	WELLENDICHTRI. 25X40X7 BAUM3SL	SHAF.SEAL RING 25X40X7 BAUM3SL	1
77	0760 305271	WELLENDICHTRING 30X52X7	SHAFT SEAL RING 30X52X7	1
79	0137 120000	FEDERSCHEIBE DIN0137-B12	SPRING WASHER DIN0137-B12	1
81	800.30.081.010	PASSSCHEIBE 30X35X0,10	THRUST WASHER 31X36X0,10	X
81	800.30.081.020	PASSSCHEIBE 30X35X0,20	THRUST WASHER 31X36X0,20	X
81	800.30.081.030	PASSSCHEIBE 30X35X0,30	THRUST WASHER 31X36X0,30	X
82	560.30.081.000	PASSSCHEIBE 30,5X45X0,10	THRUST WASHER 30,5X45X0,10	X
82	560.30.081.100	PASSSCHEIBE 30,7X47X0,15	THRUST WASHER 30,7X47X0,15	X
82	560.30.081.200	PASSSCHEIBE 30,5X45X0,30	THRUST WASHER 30,5X45X0,30	X
83	800.30.019.000	ZYL.R.LAGER NJ206 ECP/C3HVC058	CYL.ROLLBEAR.NJ206ECP/C3HVC058	2
85	6946 005	SCHEIBENFEDER 5X6,5 GEHÄRTET	WOODRUFF KEY 5X6,5 HARDED	1
86	0888 030050	SCHEIBENFEDER DIN6888-3X5X13	WOODRUFF KEY DIN6888-3X5X13	1

FIG	TEILNR/PARTNR	BEZEICHNUNG	DESCRIPTION	QTY
18	800.30.018.020	MUTTER M16X1 SW=30 03	NUT M16X1 WS=30 03	1
20	0888 030050	SCHEIBENFEDER DIN6888-3X5X13	WOODRUFF KEY DIN6888-3X5X13	1
21	6946 005	SCHEIBENFEDER 5X6,5 GEHÄRTET	WOODRUFF KEY 5X6,5 HARDED	1
24	0472 042175	SICHERUNGSRING DIN0472-42X1,75	CIRCLIP DIN0472-42X1,75	1
26	0770 010013	O-RING 10,00X1,30 NBR 70 SH	O-RING 10,00X1,30 NBR 70 SH	1
53	0625 069050	RILLENKUGELLAGER 6905 J1LLUC3	BALL BEARING 6905 J1LLUC3	1
57	800.30.057.100	AGW KPL. 450-650 06	BALANCER SHAFT CPL. 450-650 06	1
59	800.30.059.000	ANTRIEBSWELLE AGW 03	MAIN SHAFT BALANCER SHAFT 03	1
60	800.30.059.050	ANTRIEBSRAD AGW-WELLE 29-Z 03	GEAR WHEEL B.SH.-SHAFT 29-T 03	1

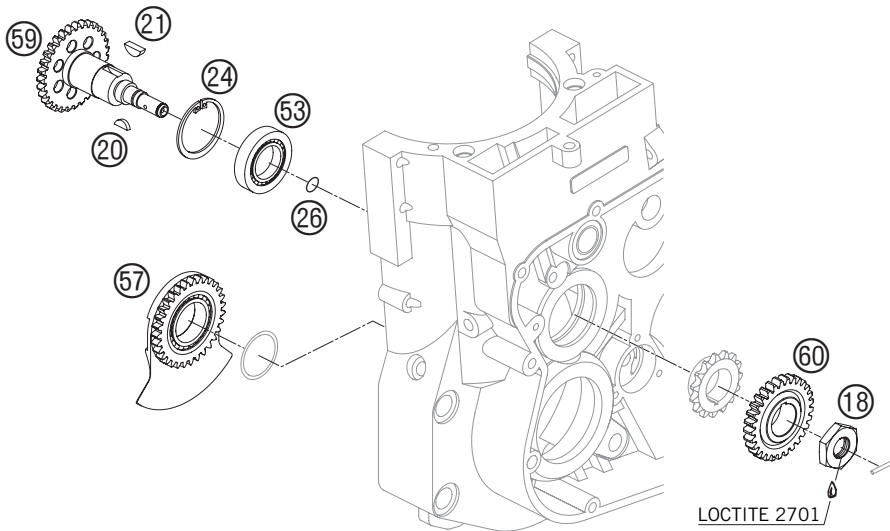
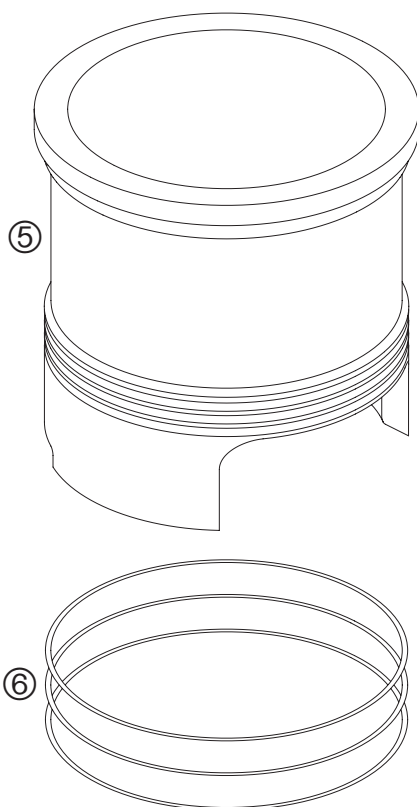

FIG	TEILNR/PARTNR	BEZEICHNUNG	DESCRIPTION	QTY
5	810.30.005.000	ZYLINDERLAUFBÜCHS.100MM 450 03	CYLINDER LINER 100MM 450 03	1
5	815.30.005.000	ZYLINDERLAUFBÜCHS.100MM 550 03	CYLINDER LINER 100MM 550 03	1
5	820.30.005.000	ZYLINDERLAUFBÜCHS.100MM 650 03	CYLINDER LINER 100MM 650 03	1
6	0770 102020	O-RING 102,00X2,00 VITON 02	O-RING 102,00X2,00 VITON 02	3



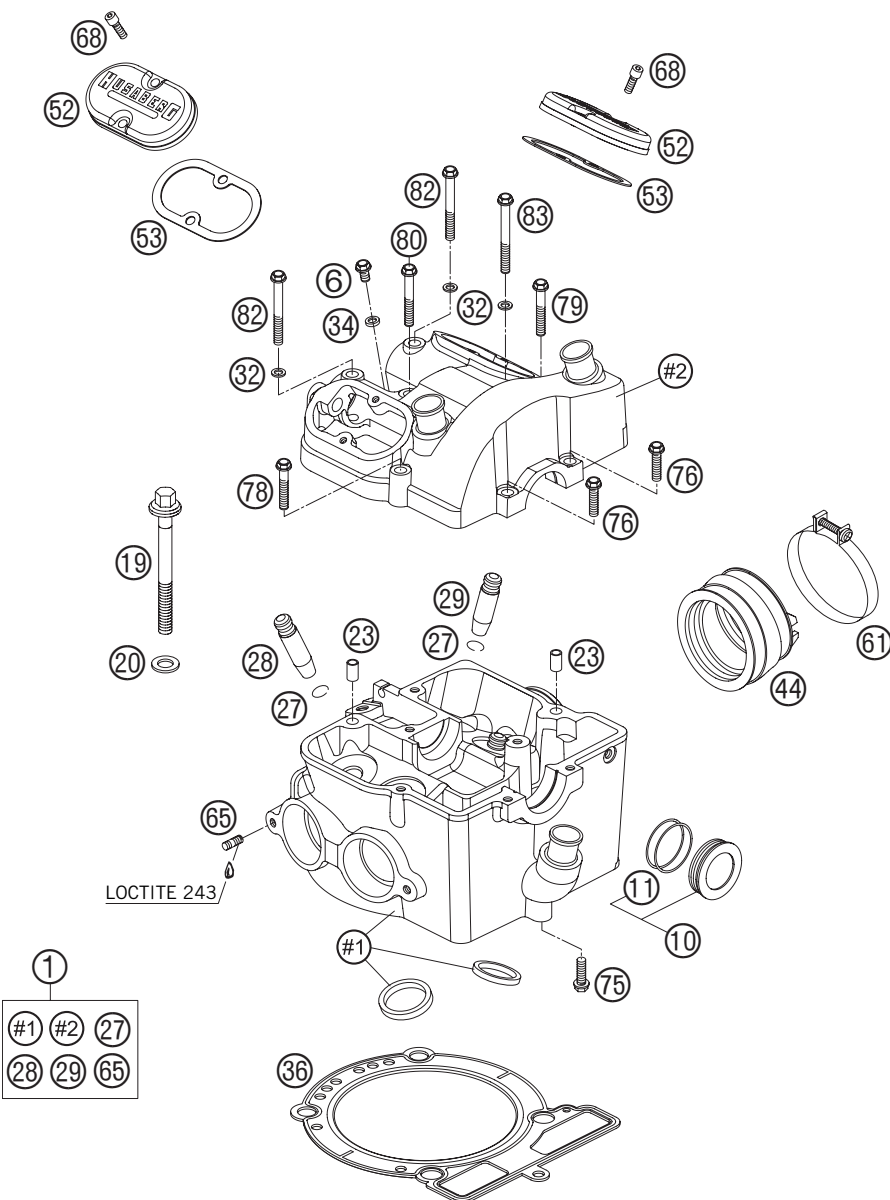

FIG	TEILNR/PARTNR	BEZEICHNUNG	DESCRIPTION	QTY
1	800.36.020.044	ZYLINDERKOPF KPL. 04	CYLINDER HEAD CPL. 04	1
6	590.36.006.090	ENTLÜFTUNGSSCHRAUBE M6X10 KPL.	VENT SCREW M6X10 CPL.	1
10	800.36.010.050	VERSCHLUSSDECKEL 03	CLOSING COVER 03	1
11	0770 291016	O-RING 29,10X1,60 NBR 70	O-RING 29,10X1,60 NBR 70	2
19	580.36.099.100	BUNDSCHRAUBE M10X80 SW=13 10.9	COLLAR SCREW M10X80 WS=13 10.9	4
20	590.36.090.000	SCHEIBE 10,8X18,8X1,5	WASHER 10,8X18,8X1,5	4
23	590.30.023.000	PASSHÜLSE 6X8X11,5	DOWEL 6X8X11,5	2
27*	0993 012000	SPRENGRING DIN7993-RW12	CIRCLIP DIN7993-RW12	4
28*	590.36.026.000	VENTILFÜHRUNG AUSLASS	VALVE GUIDE EXHAUST	2
29*	590.36.025.000	VENTILFÜHRUNG EINLASS	VALVE GUIDE INTAKE	2
32	0603 061001	CU-DICHTRING DIN7603-6X10X1	CU-SEAL RING DIN7603-6X10X1	3
34	580.36.065.100	CU-DICHTRING 6 X 10 X 2	CU-SEAL RING 6 X 10 X 2	1
36	810.30.036.000	ZYLINDERKOPFDICHTUNG 450/550/650	CYLINDER HEAD GASKET 450/550/650	1
44	800.36.044.000	GUMMIMUFFE 450/501/550 450/501/550	INTAKE BOOD 450/501/550 450/501/550	1
44	590.36.044.100	GUMMIMUFFE 650	INTAKE BOOT 650	1
52	800.36.052.000	VENTILDECKEL 03	VALVE COVER 03	2
53	800.36.053.000	DICHTUNG FÜR VENTILDECKEL 03	GASKET FOR VALVE COVER 03	2
61	590.30.061.000	SCHELLE D=56MM B=9MM M4X25	CLAMP D=56MM B=9MM M4X25	2
65	0939 060163	STIFTSCHRAUBE DIN939-M 6X16	STUD DIN939-M 6X16	2
68	0912 050163	ISK.SCHRAUBE DIN 912 M5X16	AH SCREW DIN0912-M 5X16	4
75	0015 060203	SK.BUNDSCHRAUBE M 6X20 SW=8	HH COLLAR SCREW M 6X20 WS=8	1
76	0015 060253	SK.BUNDSCHRAUBE M 6X25 SW=8	HH COLLAR SCREW M 6X25 WS=8	2
78	0015 060353	SK.BUNDSCHRAUBE M 6X35 SW=8	HH COLLAR SCREW M 6X35 WS=8	1
79	0015 060403	SK.BUNDSCHRAUBE M 6X40 SW=8	HH COLLAR SCREW M 6X40 WS=8	1
80	0015 060453	SK.BUNDSCHRAUBE M 6X45 SW=8	HH COLLAR SCREW M 6X45 WS=8	1
82	0015 060556	SK.BUNDSCHR. M 6X55 SW=8 10.9	HH COLLAR SCR. M6X55 WS=8 10.9	2
83	0015 060603	SK.BUNDSCHRAUBE M 6X60 SW=8	HH COLLAR SCREW M 6X60 WS=8	1

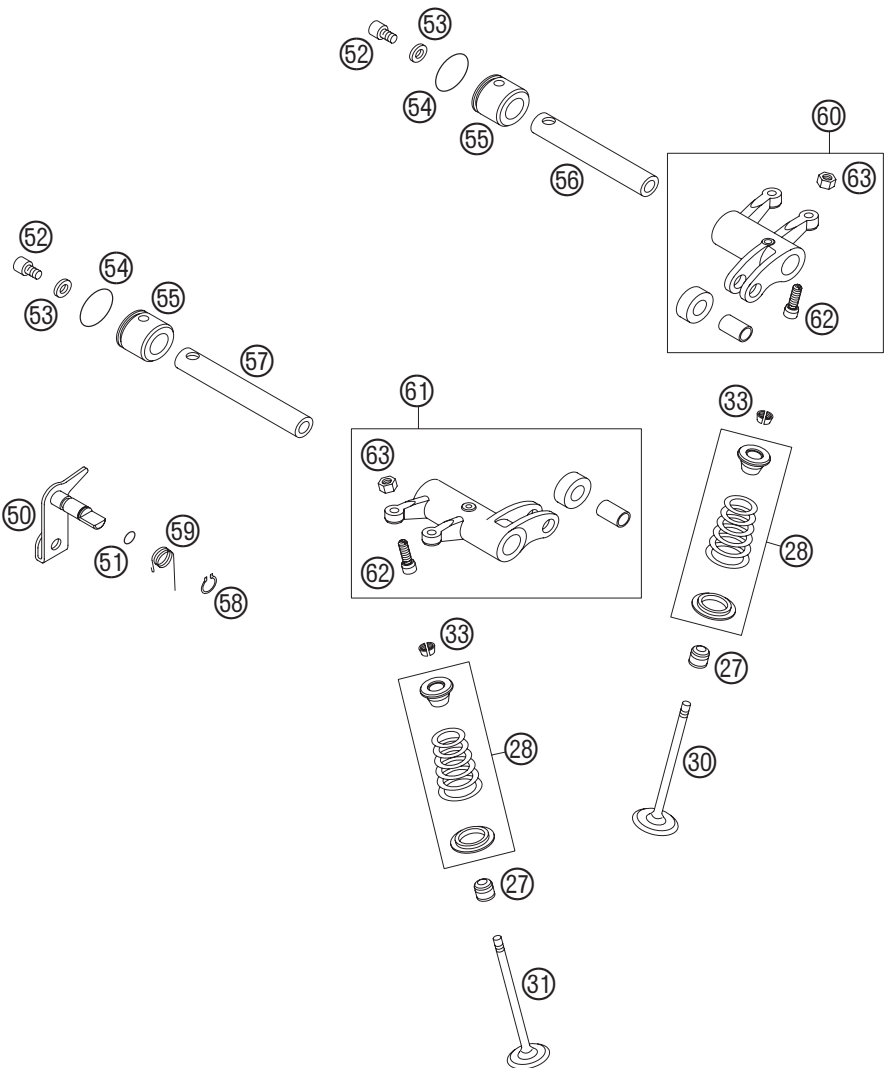

FIG	TEILNR/PARTNR	BEZEICHNUNG	DESCRIPTION	QTY
27	590.36.027.000	VENTILSCHAFTDICHTUNG RACING	VALVE-STEM SEALING RACING	4
28	594.36.028.044	VENTILFEDER KONISCH KPL. 03	VALVE SPRING CONICAL CPL. 03	4
30	590.36.030.000	EINLASSVENTIL D=35MM	INTAKE VALVE D=35MM	2
31	590.36.031.000	AUSLASSVENTIL D=30MM	EXHAUST VALVE D=30MM	2
33	590.36.033.000	VENTILKEGELSTÜCK KK 6 H	VALVE COLLET KK 6 H	8
50	590.36.050.000	DEKOWELLE KPL.	DECOMPRESSION SHAFT CPL.	1
51	0770 051016	O-RING 5,10X1,60 NBR 70	O-RING 5,10X1,60 NBR 70	1
52	0912 050083	ISK.SCHRAUBE DIN 912 M 5X8	AH SCREW DIN 912 M 5X8	2
53	590.36.060.010	SCHEIBE ALU 5,2X10X2	SHIM ALU 5,2X10X2	2
54	0770 191016	O-RING 19,10X1,60 NBR 70	O-RING 19,10X1,60 NBR 70	2
55	590.36.061.095	ENDKAPPE KIPPHEBELACHSE	END CAP ROCKER ARM SHAFT	2
56	590.36.056.000	KIPPHEBELACHSE EINLASS	ROCKER ARM SHAFT INTAKE	1
57	590.36.057.000	KIPPHEBELACHSE AUSLASS	ROCKER ARM SHAFT EXHAUST	1
58	0471 080000	SICHERUNGSRING DIN0471- 8X0,8	CIRCLIP DIN0471- 8X0,8	1
59	590.36.059.000	DEKOHEBELFEDER	DECOMPRESSION LEVER SPRING	1
60	590.36.060.144	KIPPHEBEL EINLASS KPL.	ROCKER ARM INTAKE CPL.	1
61	590.36.061.144	KIPPHEBEL AUSLASS KPL.	ROCKER ARM EXHAUST CPL.	1
62	590.36.062.000	EINSTELLSCHRAUBE M6X0,75	ADJUSTMENT SCREW M6X0,75	4
63	590.36.062.100	MUTTER M6X0,75	NUT M6X0,75	4

FIG	TEILNR/PARTNR	BEZEICHNUNG	DESCRIPTION	QTY
1	800.36.001.000	STEUERKETTENFÜHRUNG 04	TIMING CHAIN GUIDE 04	1
2	800.36.002.100	SPANNSCHIENE 450-550 05	TENSIONER 450-550 05	1
2	820.36.002.000	SPANNSCHIENE 650 05	TENSIONER 650 05	1
3	590.36.003.000	STEUERKETTENSPIANNER KPL.RACING	TIMINGCHAIN TENSIONER CPL.RAC.	1
10	800.36.010.000	NOCKENWELLE 450/501/550 03	CAMSHAFT 450/501/550 03	1
10	820.36.010.000	NOCKENWELLE 650 04	CAMSHAFT 650 04	1
11	800.36.011.100	NOCKENWELLENRAD 3/8 (Z=30) 05	CAMSHAFT GEAR 05	1
13	810.36.013.100	STEUERKETTE 64L DID 450 05	TIMING CHAIN 64L DID 450 05	1
13	800.36.013.100	STEUERKETTE 66L DID 550 05	TIMING CHAIN 66L DID 550 05	1
13	820.36.013.100	STEUERKETTE G67BW 70L DID 650 05	TIMING CHAIN G67BW 70L DID 650 05	1
14	800.36.013.150	STEUERKETTENGLIED DID 05	LINK FOR TIMING CHAIN DID 05	1
15	0625 062014	RILLENKUGELLAGER 6201	BALL BEARING 6201	2
16	590.36.016.000	AUTODEKOWELLE	AUTO DECOMPRESSION SHAFT	1
17	590.36.017.000	FEDER FÜR AUTODEKO	SPRING FOR AUTODECOMPRESSION	1
21	800.36.001.050	DISTANZBÜCHSE KETTENFÜHRU. 04	SPACER BUSHING TIM.CH.GUIDE 04	1
22	800.36.002.050	STUFENBÜCHSE 04	STEPPED SPACER BUSHING 04	1
23	590.36.003.050	DICHTUNG STEUERKETTENSPIANNER	GASKET TIMING CHAIN TENSIONER	1
27	590.36.060.010	SCHEIBE ALU 5,2X10X2	SHIM ALU 5,2X10X2	1
37	800.36.037.000	STEUERKETTENRITZEL 03	TIMING CHAIN GEAR 03	1
45	0984 080103	ISK.SCHRAUBE DIN7984 M8X10	AH SCREW DIN7984-M 8X10	2
50	0015 050163	SK.BUNDSCHRAUBE M 5X16 SW=8	HH COLLAR SCREW M 5X16 WS=8	1
52	0015 060123	SK.BUNDSCHRAUBE M 6X12 SW=8	HH COLLAR SCREW M 6X12 WS=8	1
54	0015 060163	SK.BUNDSCHRAUBE M 6X16 SW=8	HH COLLAR SCREW M 6X16 WS=8	2

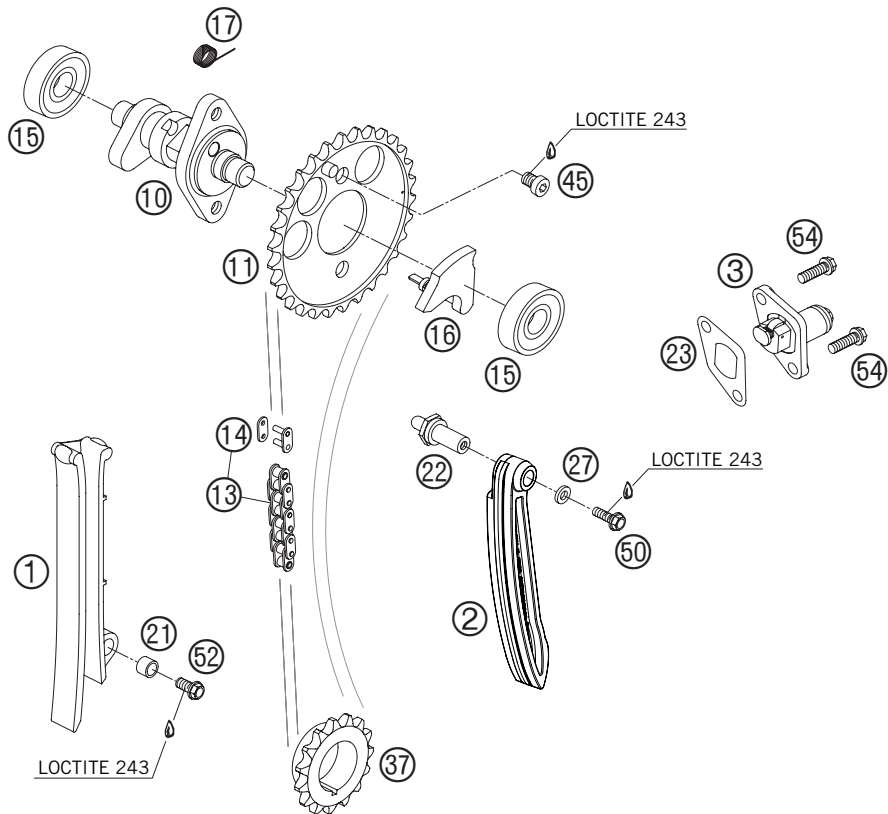

FIG	TEILNR/PARTNR	BEZEICHNUNG	DESCRIPTION	QTY
1	800.38.001.000	ÖLPUMPENRAD 03	OIL PUMP GEAR 03	1
2	800.38.002.044	ÖLPUMPE KPL. 03	OIL PUMP CPL. 03	1
3	800.38.003.000	ÖLPUMPENDECKEL 03	OIL PUMP COVER 03	1
5*	580.38.005.100	ÖLFILTER LANG	OIL FILTER LONG	1
7	580.38.007.755	ANLAUFSCHEIBE 8,1 X 15 X 0,5	STOP DISK 8,1 X 15 X 0,5	1
8	0799 060000	SICH.SCHEIBE DIN6799-RS 6,0	TAB WASHER DIN6799-RS 6,0	1
10	0402 251980	NADELROL. DIN5402 NRA 2,5X19,8	NEEDLEROL. DIN5402 NRA 2,5X19,8	1
16	590.38.016.000	ÖLSIEB 15X83MM	OIL SCREEN 15X83MM	1
17	590.38.017.000	VERSCHL.SCHRAUBE M20X1,5 SW=13	PLUG M20X1,5 WS=13	1
25	0770 125015	O-RING 12,5X1,5 NBR	O-RING 12,5X1,5 NBR	2
27	0770 020170	O-RING 17,17X1,78 GLO	O-RING 17,17X1,78 GLO	1
30	0770 380020	O-RING 38,00X2,00 NBR 70 SH	O-RING 38,00X2,00 NBR 70 SH	2
41	800.38.041.000	ÖLFILTERDECKEL 03	OIL FILTER COVER 03	1
45	0912 050503	ISK.SCHRAUBE DIN912-M5X50 10.9	AH SCREW DIN912-M5X50 10.9	2
50	0016 040133	SK.BUNDSCHRAUBE M 4X13 SW=6	HH COLLAR SCREW M 4X13 WS=6	3

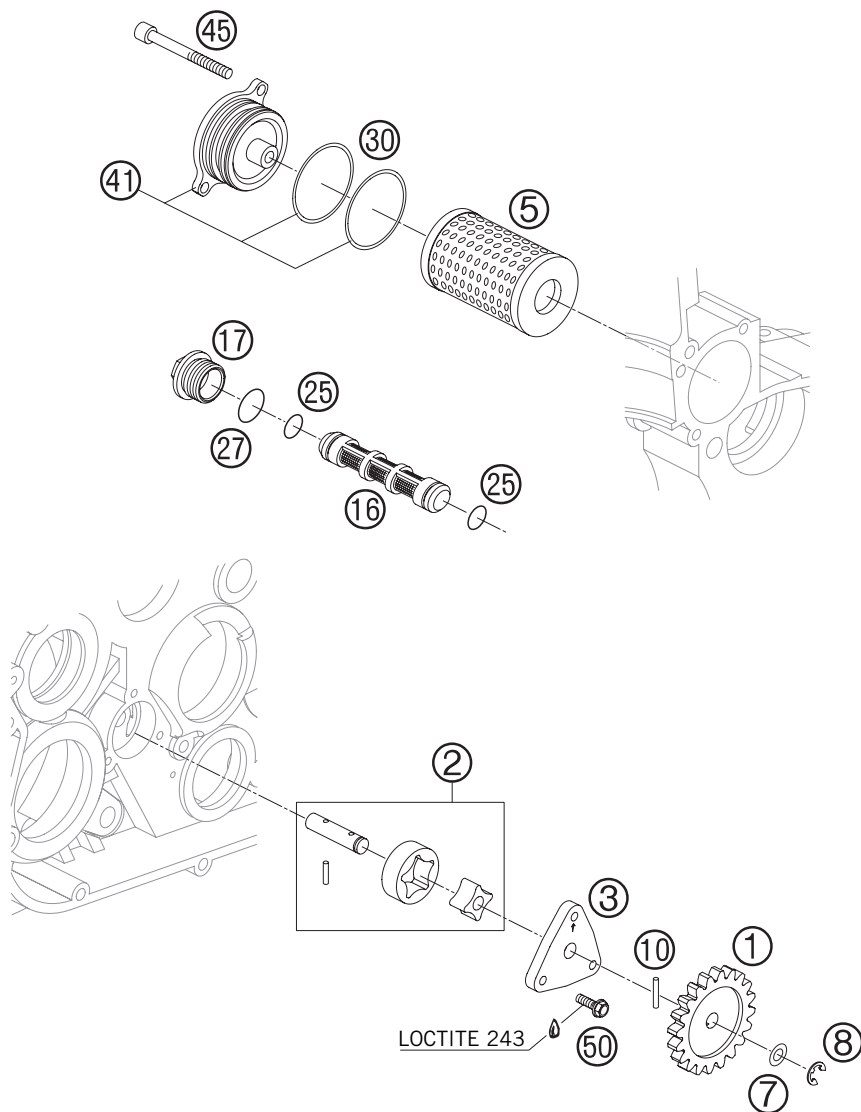
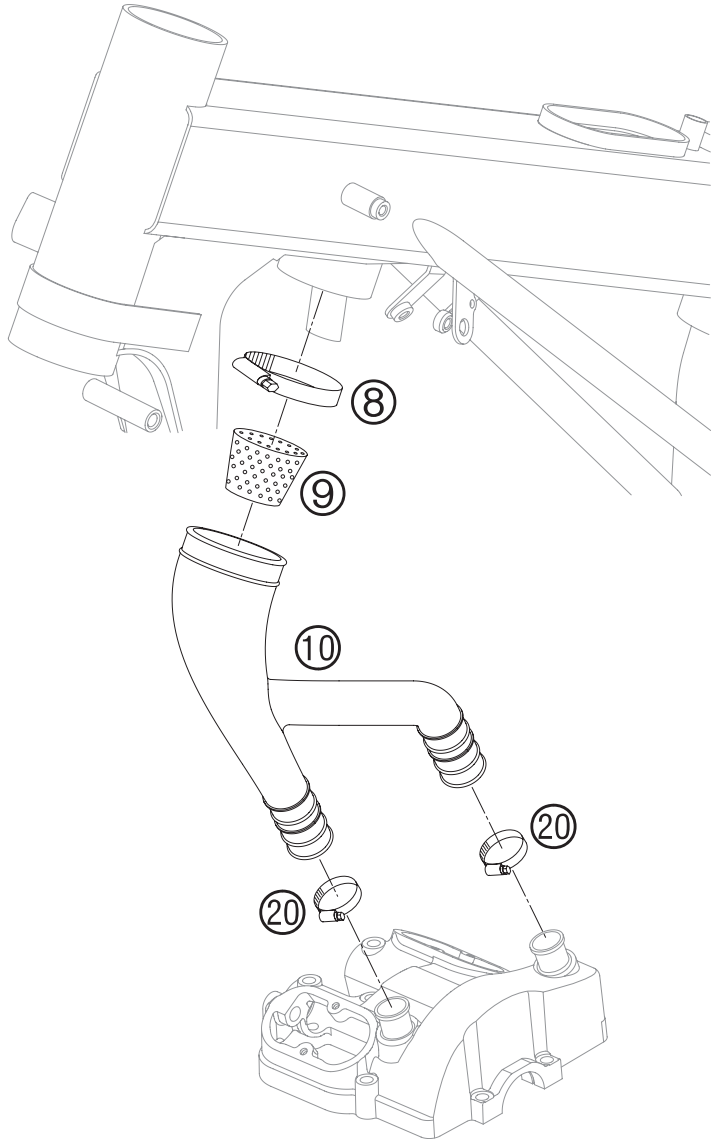

FIG	TEILNR/PARTNR	BEZEICHNUNG	DESCRIPTION	QTY
8	460.05.058.000	SCHLAUCHBINDER 40-60MM	HOSE CLAMP 40-60MM	1
9	800.30.089.000	FILTER F. MOTORENTLÜFTUNG 04	FILTER FOR BREATHER SYSTEM 04	1
10	800.30.090.000	ENTLÜFTUNGSSCHLAUCH MOTOR 04	BREATHER HOSE ENGINE 04	1
20	100.01.020.000	SCHLAUCHKLEMME GEMI 16-27	HOSE CLAMP GEMI 16-27	2



ACHTUNG !!!
Vor dem Einbau des Vergasers, Bedüsung kontrollieren.
CAUTION !!!
Before mounting the carburetor, check the jetting.

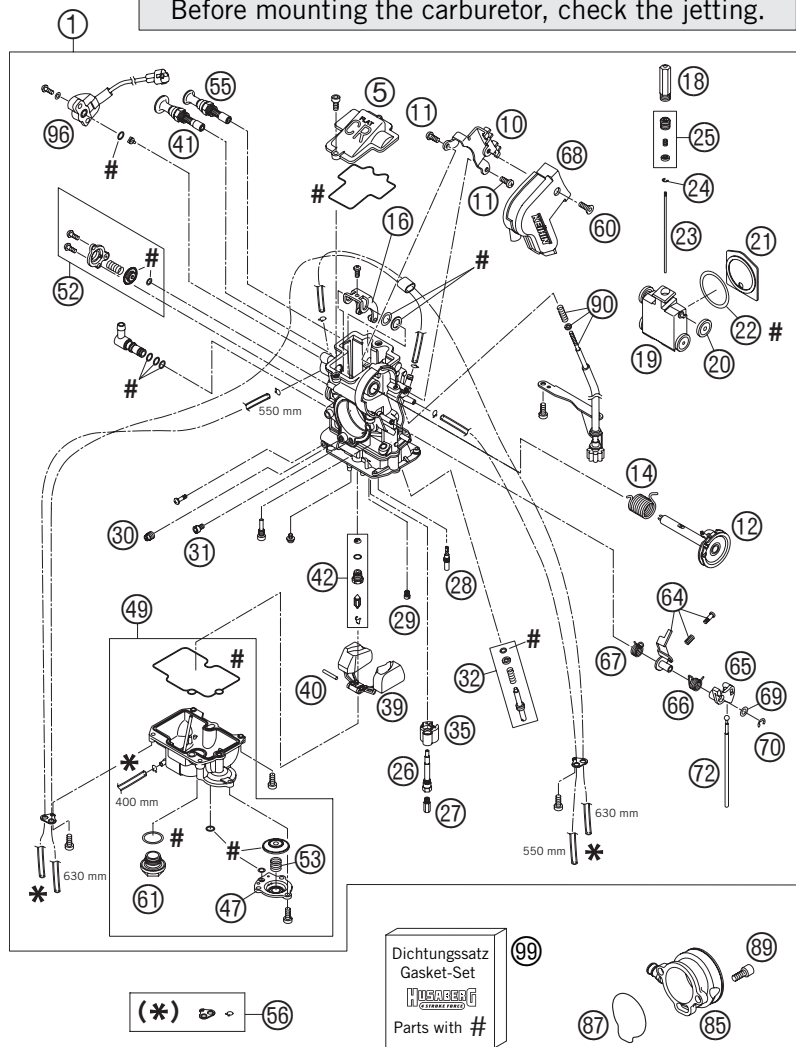

FIG	TEILNR/PARTNR	BEZEICHNUNG	DESCRIPTION	QTY
1	800.31.001.300	VERGASER KEIHIN FCR-MX39 05 450 FE	CARBURETOR KEIHIN FCR-MX39 05 450 FE	1
1	800.31.001.400	VERGASER KEIHIN FCR-MX41 05 550 FE	CARBURETOR KEIHIN FCR-MX41 05 550 FE	1
1	800.31.001.500	VERGASER KEIHIN FCR-MX41 05 650 FE	CARBURETOR KEIHIN FCR-MX41 05 650 FE	1
5	573.31.027.000	VERGASERDECKEL 2002	CARBURETOR COVER 2002	1
10	573.31.080.000	HALBLECH FÜR GASSEILE	BRACKET PLATE FOR THR. CABLE	1
11	573.31.055.000	SCHRAUBE M 5 X 8	SCREW M 5 X 8	2
12	573.31.046.000	SEILZUGROLLE KPL.	THROTTLE SHAFT CPL.	1
14	573.31.046.050	FEDER SEILZUGROLLE	COIL SPRING THROTTLE SHAFT	1
16	573.31.035.051	GASSCHIEBERARM KPL.	LINK ARM THROTTLE VALVE CPL.	1
18	590.31.029.006	SCHIEBERANSCHLAG L=44MM 04 450-650 FE+FS (EU+AUS)	SLIDE STOP L=44MM 04 450-650 FE+FS (EU+AUS)	1
19	573.31.035.000	GASSCHIEBER KPL.	THROTTLE VALVE CPL.	1
20	590.31.035.050	LAGERROLLE GASSCHIEBER	BUSHING THROTTLE VALVE	4
21	573.31.035.153	DICHTPL. GASSCH. FCR-MX M. 04	GASKET PLATE THROTTLE VALVE 04	1
22	590.31.035.052	DICHTSCHEIBE GASSCHIEBER	GASKET WASHER THROTTLE VALVE	1
23	590.31.023.200	DÜSENNADEL KEIHIN OBVT 450-650 FE+FS	JET NEEDLE KEIHIN OBVT 450-650 FE+FS	1
23	573.31.034.300	DÜSENNADEL KEIHIN OBEKR	JET NEEDLE KEIHIN OBEKR	X
24	590.31.029.000	NADELCLIP	BAR CLIP	1
25	573.31.032.000	NADELSCHRAUBE KPL.	NEEDLE SET SCREW CPL.	1
26	590.31.121.000	NADEL DÜSE FCR-MX	NEEDLE JET FCR-MX	1
27	545.31.623.160	HAUPTDÜSE GR.160 KEIHIN 650 FE+FS	MAIN JET 160 KEIHIN 650 FE+FS	1
27	545.31.623.162	HAUPTDÜSE GR.162 KEIHIN	MAIN JET 162 KEIHIN	X
27	545.31.623.165	HAUPTDÜSE GR.165 KEIHIN	MAIN JET 165 KEIHIN	X
27	545.31.623.168	HAUPTDÜSE GR.168 KEIHIN	MAIN JET 168 KEIHIN	X
27	545.31.623.170	HAUPTDÜSE GR.170 KEIHIN	MAIN JET 170 KEIHIN	X
27	545.31.623.172	HAUPTDÜSE GR.172 KEIHIN	MAIN JET 172 KEIHIN	X
27	545.31.623.175	HAUPTDÜSE GR.175 KEIHIN	MAIN JET 175 KEIHIN	X
27	545.31.623.178	HAUPTDÜSE GR.178 KEIHIN 450 FE+FS	MAIN JET 178 KEIHIN 450 FE+FS	1
27	545.31.623.180	HAUPTDÜSE GR.180 KEIHIN	MAIN JET 180 KEIHIN	X

ACHTUNG !!!
Vor dem Einbau des Vergasers, Bedüsung kontrollieren.
CAUTION !!!
Before mounting the carburetor, check the jetting.

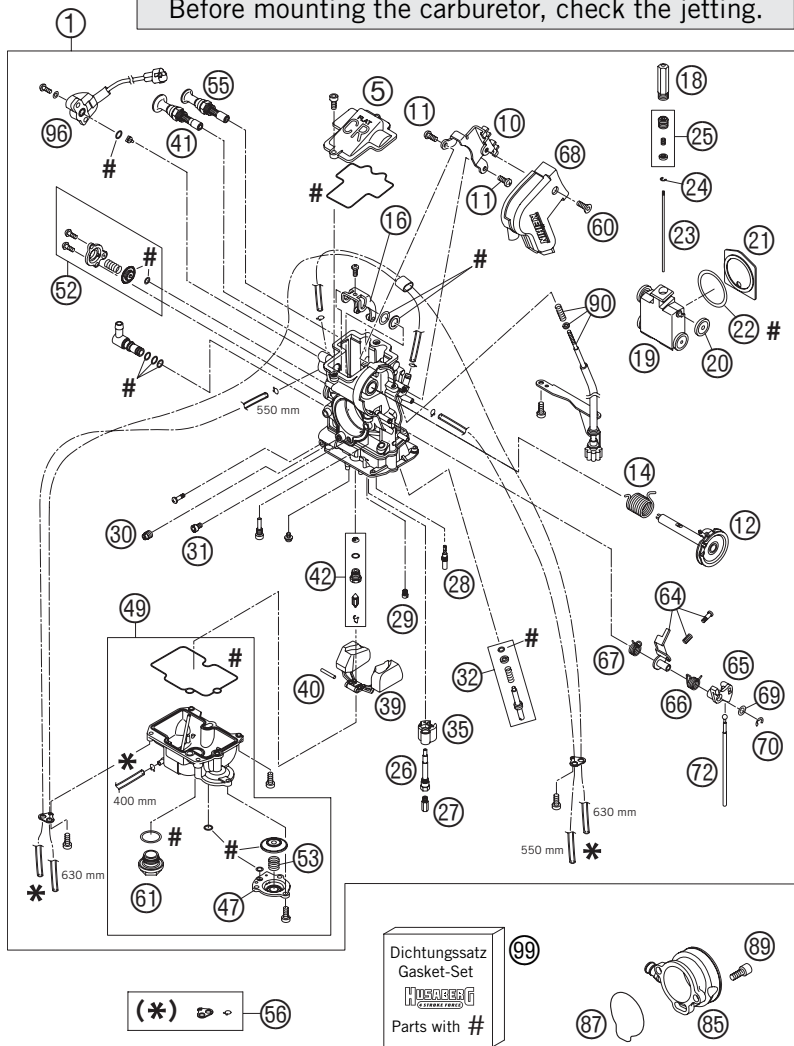

FIG	TEILNR/PARTNR	BEZEICHNUNG	DESCRIPTION	QTY
27	545.31.623.182	HAUPTDÜSE GR.182 KEIHIN 550 FE	MAIN JET 182 KEIHIN 550 FE	1
27	545.31.623.185	HAUPTDÜSE GR.185 KEIHIN	MAIN JET 185 KEIHIN	X
27	545.31.623.188	HAUPTDÜSE GR.188 KEIHIN	MAIN JET 188 KEIHIN	X
27	545.31.623.190	HAUPTDÜSE GR.190 KEIHIN	MAIN JET 190 KEIHIN	X
28	545.31.607.038	LEERLAUFDÜSE GR.38 KEIHIN 450-650 FE+FS	IDLE JET 38 KEIHIN 450-650 FE+FS	1
28	545.31.607.040	LEERLAUFDÜSE GR.40 KEIHIN	IDLE JET 40 KEIHIN	X
28	545.31.607.042	LEERLAUFDÜSE GR.42 KEIHIN	IDLE JET 42 KEIHIN	X
28	545.31.607.045	LEERLAUFDÜSE GR.45 KEIHIN	IDLE JET 45 KEIHIN	X
29	590.31.051.085	STARTDÜSE 85	STARTER JET 85	1
30	573.31.007.100	LEERLAUFLUFTDÜSE GR.100 KEIHIN	IDLE AIR JET 100 KEIHIN	1
31	573.31.037.200	HAUPTLUFTDÜSE GR.200 KEIHIN	MAIN AIR JET 200 KEIHIN	1
32	590.31.017.100	GEMISCHREGULIERSCHR.KPL.FCR-MX	ADJUST SCREW CPL. FCR-MX	1
35	573.31.085.000	DÄMPFUNGSKÖRPER	BUFFER PLATE	1
39	573.31.009.000	SCHWIMMER KPL.	FLOAT CPL.	1
40	573.31.008.000	STIFT SCHWIMMER	ARM PIN FLOAT	1
41	573.31.075.000	WARMSTARTBETÄTIGUNG KPL.	HOT-STARTER VALVE CPL.	1
42	573.31.020.000	SCHWIMMERNADELVENTIL KPL.	NEEDLE VALVE CPL.	1
47	573.31.060.000	GEHÄUSE BESCHLEUNIGERPUMPE	COVER ACCELERATOR PUMP	1
49	800.31.011.044	SCHWIMMERGEHÄUSE KPL. SET 04	FLOAT CHAMBER CPL. SET 04	1
52	573.31.090.000	LUFTABSCHNEIDEVENTIL 2002 NUR FÜR 650 FE+FS	AIR CUT VALVE 2002 ONLY FOR 650 FE+FS	1
53	590.31.059.000	DRUCKFEDER	COIL SPRING	1
55	573.31.048.000	KALTSTARTBETÄTIGUNG KPL.	STARTER VALVE CPL.	1
56	800.31.098.000	ENTL.SCHL. FCR-MX KEIHIN KPL.	BREATH.HOSE FCR-MX KEIHIN CPL.	1
60	0965 050103	SENKSCHRAUBE DIN 965 M5X10	FLAT HEAD SCREW DIN0965-M 5X10	1
61*	545.31.699.000	VERSCHLUSSSCHRAUBE M 18X1	PLUG M 18X1	1
64	573.31.062.000	VERBINDUNGSHEBEL KPL.	INTERMEDIATE LEVER CPL.	1
65	573.31.056.000	ANLENKHEBEL	LINK LEVER	1
66	573.31.059.000	FEDER ANLENKHEBEL	SPRING LINK LEVER	1
67	573.31.159.000	FEDER VERBINDUNGSHEBEL	SPRING INTERMEDIATE LEVER	1
68	573.31.038.000	VERGASER ABDECKUNG	CARBURETOR COVER	1
69	573.31.087.000	SCHEIBE ANLENKHEBEL	WASHER LINK LEVER	1
70	573.31.084.000	SICHERUNGSSCHEIBE E-FORM	E-CLIP	1

ACHTUNG !!!
Vor dem Einbau des Vergasers, Bedüsung kontrollieren.
CAUTION !!!
Before mounting the carburetor, check the jetting.

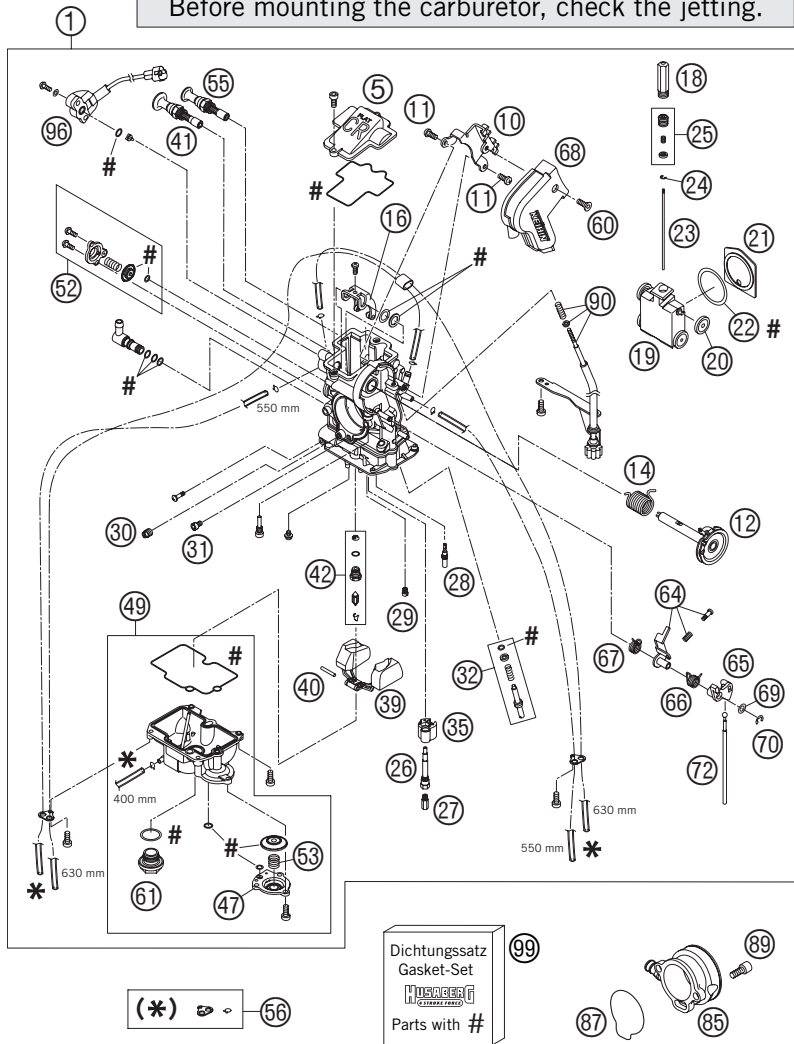
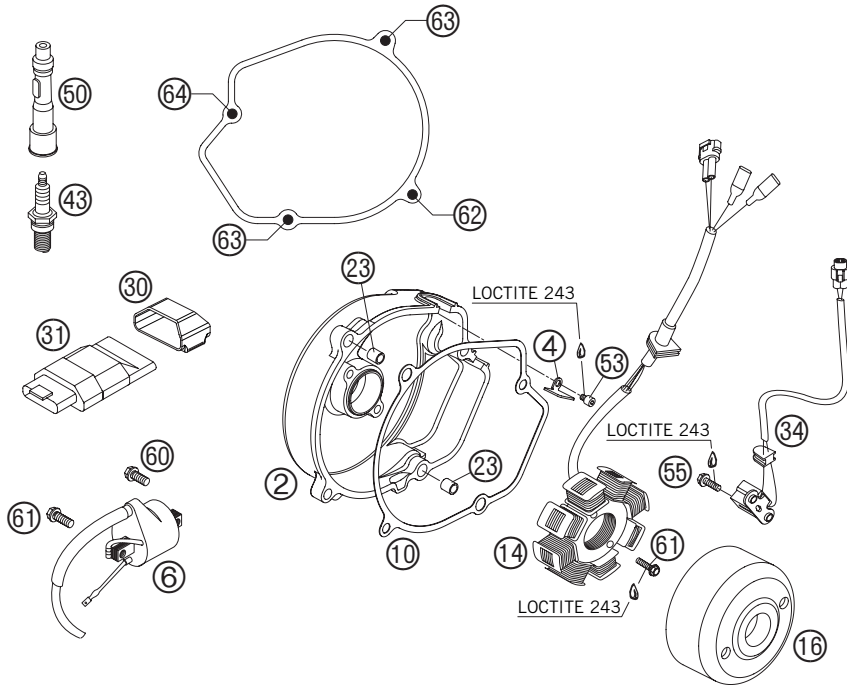

FIG	TEILNR/PARTNR	BEZEICHNUNG	DESCRIPTION	QTY
72	573.31.061.000	GESTÄNGE BESCHLEUNIGERPUMPE	ROD ACCELERATOR PUMP	1
85	590.31.040.200	ANSAUGTRICHTER FCR/FCR-MX 02 SEITLICH GESCHLOSSEN	INTAKE FUNNEL FCR/FCR-MX 02 SIDEWARDS CLOSED	1
87	590.31.040.010	O-RING FÜR ANSAUGTRICHTER	O-RING FOR INTAKE FUNNEL	1
89	0912 050123	ISK.SCHRAUBE DIN 912 M5X12	AH SCREW DIN0912-M 5X12	2
90	800.31.025.000	STELLSCHRAUBE KPL. FCR-MX 04	STOP SCREW CPL. FCR-MX 04	1
96	573.31.077.000	SENSOR GASSCHIEBERPOSITION	THROTTLE POSITION SENSOR	1
99	573.31.099.000	DICHTUNGSSATZ FCR-MX KEIHIN	GASKET SET FCR-MX KEIHIN	1

FIG	TEILNR/PARTNR	BEZEICHNUNG	DESCRIPTION	QTY
2	800.30.002.100	ZÜNDUNGSDECKEL ALU FE, FS	IGNITION COVER ALU FE, FS	1
4	800.39.002.050	HALBLECH STATORKABEL	SUPPORT FOR STATOR WIRE	1
6	503.39.006.000	ZÜNDSPULE "IG3834"	IGNI.COIL KOKU.3834 125-380'98	1
10	800.30.040.100	ZÜNDUNGSDECKELDICHUNG	IGNITION COVER GASKET	1
14	800.39.004.000	STATOR HUSABERG FS/FE FE, FS	STATOR HUSABERG FS/FE FE, FS	1
16	800.39.005.000	ROTOR HUSABERG FS/FE FE, FS	FLYWHEEL HUSABERG FS/FE FE, FS	1
23	590.30.023.000	PASSHÜLSE 6X8X11,5	DOWEL 6X8X11,5	2
30	800.39.030.100	HALTEGUMMI FÜR CDI	RUBBER HOLDER FOR CDI	1
31	810.39.031.100	ELEKTRONIKBOX 450	CDI UNIT 450	1
31	815.39.031.000	ELEKTRONIKBOX 550	CDI UNIT 550	1
31	820.39.031.000	ELEKTRONIKBOX 650	CDI UNIT 650	1
34	590.39.034.000	IMPULSGEBER KOKUSAN 4K3-A/B	PULSER COIL KOKUSAN 4K3-A/B	1
43	590.39.093.100	ZÜNDKERZE NGK DCPR8E	SPARK PLUG NGK DCPR8E	1
50	584.39.090.000	ZÜNDKERZENSTECKER SD05EG	SPARK PLUG CONNECT. SD05EG	1
53	0912 060083	ISK.SCHRAUBE DIN 912 M6X8	AH SCREW DIN0912-M 6X 8	1
55	0015 050163	SK.BUNDSCHRAUBE M 5X16 SW=8	HH COLLAR SCREW M 5X16 WS=8	2
60	0015 060163	SK.BUNDSCHRAUBE M 6X16 SW=8	HH COLLAR SCREW M 6X16 WS=8	1
61	0015 060203	SK.BUNDSCHRAUBE M 6X20 SW=8	HH COLLAR SCREW M 6X20 WS=8	1(3)
62	0015 060253	SK.BUNDSCHRAUBE M 6X25 SW=8	HH COLLAR SCREW M 6X25 WS=8	1
63	0015 060303	SK.BUNDSCHRAUBE M 6X30 SW=8	HH COLLAR SCREW M 6X30 WS=8	2
64	0015 060353	SK.BUNDSCHRAUBE M 6X35 SW=8	HH COLLAR SCREW M 6X35 WS=8	1



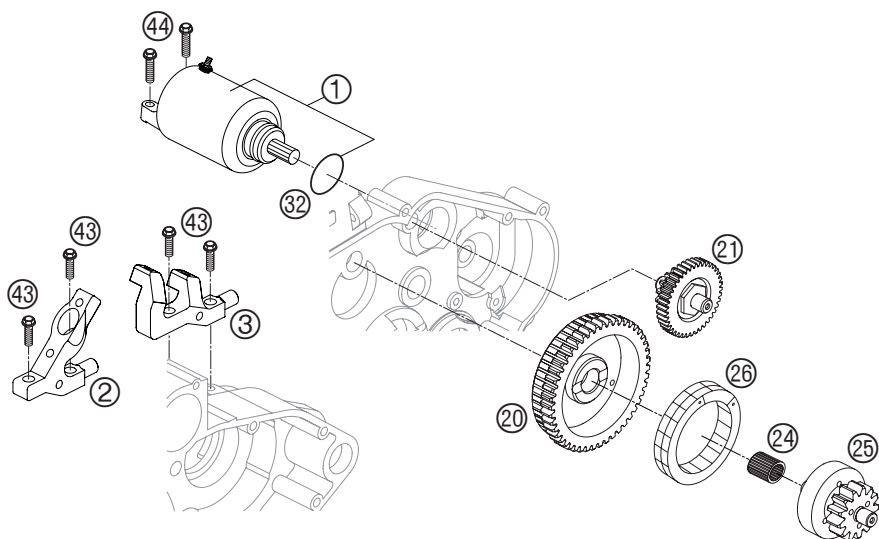
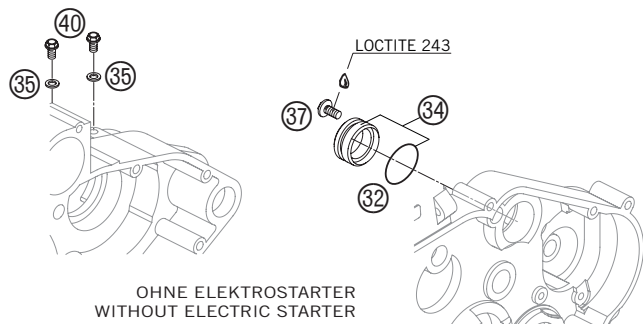

FIG	TEILNR/PARTNR	BEZEICHNUNG		DESCRIPTION	QTY
1	800.40.001.000	E-STARTERMOTOR KPL. 450	03	E-STARTER ENGINE CPL. 450	1
1	820.40.001.000	E-STARTERMOTOR KPL. 550/650	04	E-STARTER ENGINE CPL. 550/650	1
2	810.40.002.000	HALTER FÜR E-STARTER 450	04	BRACKET ELEC. STARTER ENG. 450	1
3	820.40.002.000	HALTER FÜR E-STARTER 550/650	04	BRACKET ELEC. STARTER ENG. 550/650	1
20	800.40.020.000	FREILAUFZAHNRAD	03	FREE WHEEL GEAR	1
21	800.40.021.100	DOPPELZAHNRAD DREHMOM.BEGR.	04	GEAR WHEEL TORQUE LIMITER	1
24	0405 101310	NADELKRANZ K 10X13X10	02	NEEDLE BEARING K 10X13X10	1
25	800.40.025.000	FREILAUFNABE	03	FREE WHEEL HUB	1
26	800.40.026.000	FREILAUF	03	FREE WHEEL	1
32	0770 242030	O-RING 24,20X3,00 NBR70		O-RING 24,20X3,00 NBR70	1
34	800.40.034.100	VERSCHLUSSDECKEL E-STARTER	04	PLUG ELECTRIC STARTER	1
35	0603 061001	CU-DICHTRING DIN7603-6X10X1		CU-SEAL RING DIN7603-6X10X1	2
37	0014 060103	SK.BUNDSCHRAUBE M 6X10 SW=8		HH COLLAR SCREW M 6X10 WS=8	1
40	0015 060103	SK.BUNDSCHRAUBE M 6X10 SW=8		HH COLLAR SCREW M 6X10 WS=8	2
43	0015 060203	SK.BUNDSCHRAUBE M 6X20 SW=8		HH COLLAR SCREW M 6X20 WS=8	2
44	0015 060253	SK.BUNDSCHRAUBE M 6X25 SW=8		HH COLLAR SCREW M 6X25 WS=8	2



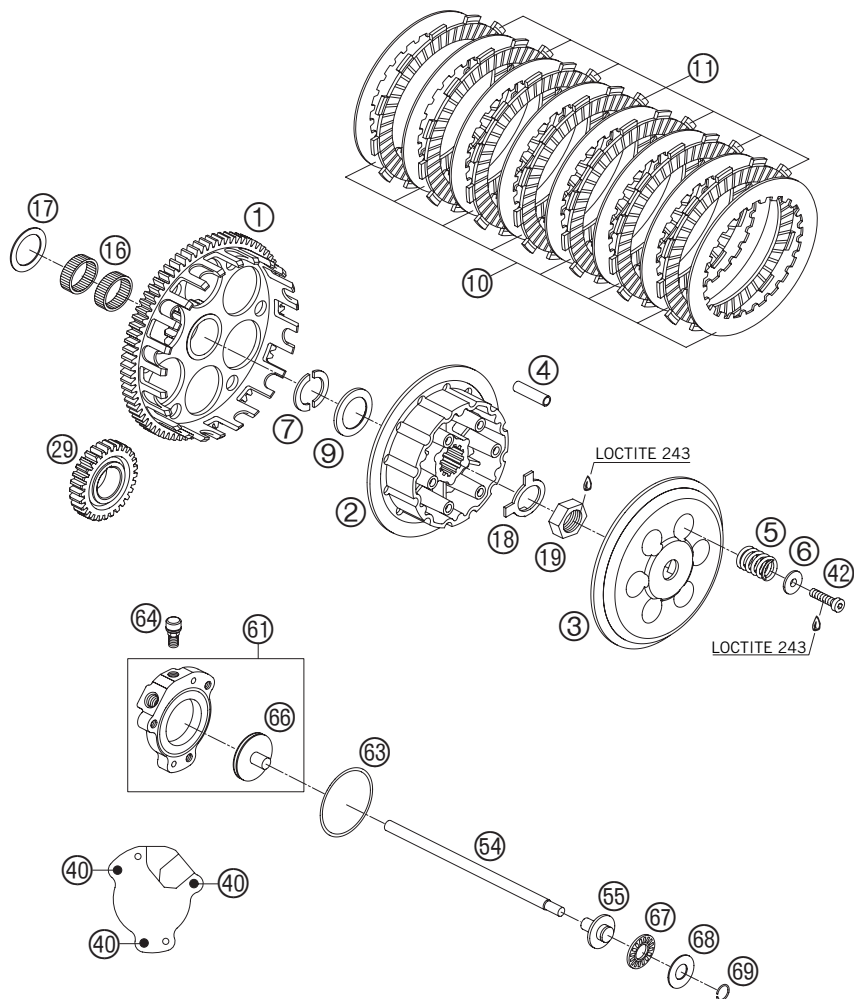

FIG	TEILNR/PARTNR	BEZEICHNUNG	DESCRIPTION	QTY
1	800.32.000.078	KUPPLUNGSKORB 03	OUTER CLUTCH HUB 03	1
2*	590.32.002.250	MITNEHMER 06	INNER HUB 06	1
3	590.32.003.200	DRUCKKAPPE 04	PRESSURE CAP 04	1
4	590.32.004.000	MITNAHMEHÜLSE D=8,L=31 2002	DRIVING SLEEVE D=8,L=31 2002	12
5	590.32.005.000	KUPPLUNGSFEDER 2,5X43MM 450/550	CLUTCH SPRING 2,5X43MM 450/550	6
5	800.32.005.000	KUPPLUNGSFEDER 2,7X43MM 650	CLUTCH SPRING 2,7X43MM 650	6
6*	590.32.006.050	FEDERTELLER 6,2X12X18X5,2 06	SPRING RETAINER 6,2X12X18X5,2 06	6
7	590.32.007.000	HALBSCHEIBE 03	HALF-WASHER 03	2
9	590.32.009.000	STUFENSCHIBE 03	STEPPED WASHER 03	1
10	590.32.010.100	ZWISCHENLAMELLE 1MM 2002	INTERMEDIATE DISC 1MM 2002	8
11	590.32.011.100	BELAGLAMELLE 2MM 04	LINING DISC 2MM 04	7
16	0405 252910	NADELKRANZ K 25X29X10	NEEDLE BEAR K 25X29X10	2
17	590.32.017.000	STÜTZSCHEIBE 25X35X1	SUPPORTWASHER 25X35X1	1
18	565.32.018.000	SICHERUNGSBLECH	LOCK WASHER	1
19	0936 181505	SK.MUTTER DIN0936-M18X1,5 RE.	HEXAGON NUT DIN0936-M18X1,5 R.	1
29	800.32.000.029	PRIMÄRRAD 29-Z 03	PRIMARY GEAR 29-T 03	1
40	0912 050163	ISK.SCHRAUBE DIN 912 M5X16	AH SCREW DIN0912-M 5X16	3
42	0984 060252	ISK.SCHRAUBE DIN6912 M6X25	AH SCREW DIN6912 M6X25	6
54	800.32.054.000	DRUCKSTANGE 03	PUSH ROD 03	1
55	503.32.054.051	DRUCKPILZ 125-380 '98	PRESSURE PIECE 125-380 '98	1
61	800.32.061.044	NEHMERZYLINDER KPL. 2004	OUTPUT CYLINDER CPL. 2004	1
63	0770 045015	O-RING 45,00X1,50 NBR 70	O-RING 45,00X1,50 NBR 70	1
64	547.32.064.000	ENTLÜFTUNGSSCHR. MIT KAPPE	BLEEDER SCREW WITH CAP	1
66	800.32.066.000	KOLBEN + O-RING 2004	PISTON + O-RING 2004	1
67	546.37.097.200	AXIALLAGER AXK 1226	AXIAL NEEDLE BEARING AXK 1226	1
68	546.37.098.200	AXIALSCHEIBE AS1226 12X26X1	AXIAL WASHER AS1226 12X26X1	1
69	0993 012000	SPRENGRING DIN7993-RW12	CIRCLIP DIN7993-RW12	1

FIG	TEILNR/PARTNR	BEZEICHNUNG		DESCRIPTION	QTY
1	800.33.070.000	KICKSTARTER KPL. USA	03	KICKSTARTER CPL. USA	1
1	800.33.070.100	KICKSTARTER KPL.	2005	KICKSTARTER CPL.	1
7	0405 182210	NADELKRANZ K 18X22X10	02	NEEDLE BEARING K 18X22X10	1
8	0405 172110	NADELKRANZ K 17X21X10		NEEDLE BEARING K 17X21X10	1
16	0760 182442	WELLENDICHTRING 18X24X4		SHAFT SEAL RING 18X24X4	1
23	800.33.023.000	SPERRKLINKE KICK	03	LOCKING PAWL KICK	1
28	800.33.028.000	KLINKENFEDER	03	RATCHET SPRING	1
40	0015 060253	SK.BUNDSCHRAUBE M 6X25 SW=8		HH COLLAR SCREW M 6X25 WS=8	1
50	800.33.050.000	KICKSTARTERWELLE	03	KICKSTARTER SHAFT	1
51	800.33.051.000	STARTERRAD	03	KICKSTARTER GEAR	1
53	800.33.053.000	STARTERZWISCHENRAD	03	INTERMEDIATE GEAR	1
54	800.33.054.000	KICKSTARTERFEDER	03	KICKSTARTER SPRING	1
60	546.33.090.000	ANLAUFSCHEIBE 17,2X25X1		STOP DISK 17,2X25X1	2
67	0471 170010	SICHERUNGSRING DIN0471-17X1		CIRCLIP DIN0471-17X1	1
70	800.33.070.150	STUFENSCHIBE KICKSTARTER		STEPPED WASHER KICKSTARTER	1

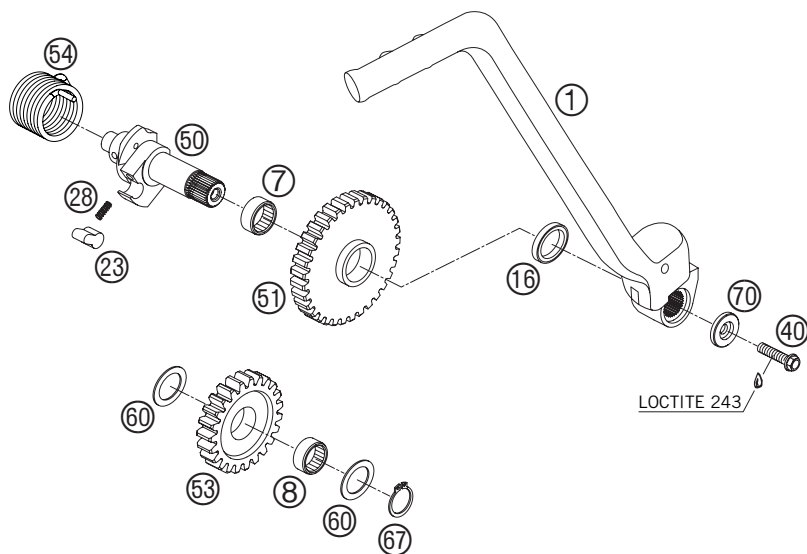
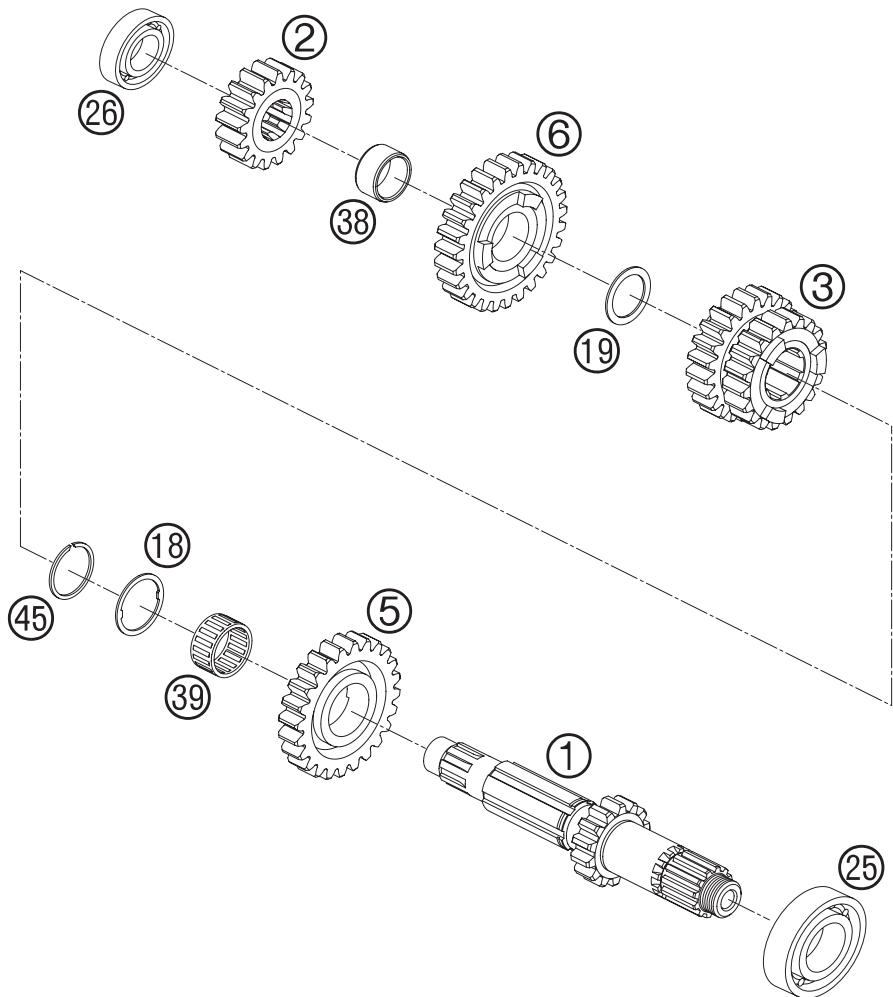

FIG	TEILNR/PARTNR	BEZEICHNUNG		DESCRIPTION	QTY
1	800.33.001.000	ANTRIEBSWELLE	04	MAIN SHAFT	04 1
2	800.33.002.017	FESTRAD 2.G 17-Z		SOLID GEAR 2ND G 17-T	1
3	800.33.003.019	SCHIEBERAD 3./4.G 19/23-Z		SLIDING GEAR 3RD/4TH G 19/23-T	1
5	800.33.005.024	LOSRAD 5.G 24-Z		IDLER GEAR 5TH G 24-T	1
6	800.33.006.027	LOSRAD 6.G 27-Z		IDLER GEAR 6TH G 27-T	1
18	800.33.018.000	STÜTZSCHEIBE 25X30X1		STOP DISC 25X30X1	1
19	800.33.019.000	STÜTZSCHEIBE 21X28X1		STOP DISC 21X28X1	1
25	0625 062054	RILLENKUGELLAGER 6205 JR C3		BALL BEARING 6205 C3 NTN	1
26	0625 062034	RILLENKUGELL. 6203 JR C3		BALL BEARING 6203 JR C3	1
38	0405 202413	NADELKRANZ K20X24X13		NEEDLE BEAR. K20X24X13	1
39	0405 222613	NADELKRANZ K 22X26X13 TN		NEEDLE BEAR. K 22X26X13 TN	1
45	0417 025000	SPRENGRING SW25		CIRCLIP SW25	1



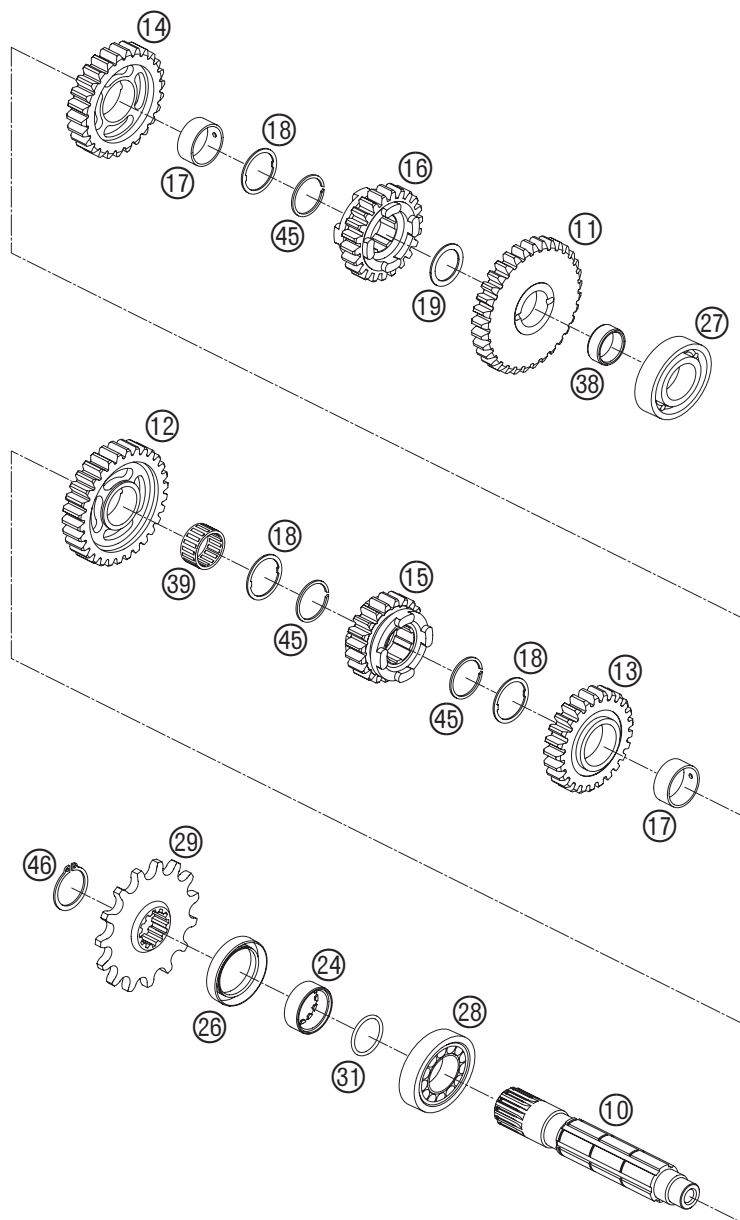

FIG	TEILNR/PARTNR	BEZEICHNUNG		DESCRIPTION	QTY
10	800.33.010.000	ABTRIEBSWELLE	04	COUNTERSHAFT	04 1
11	800.33.011.033	LOSRAD 1.G 33-Z		IDLER GEAR 1ST G 33-T	1
12	800.33.012.030	LOSRAD 2.G 30-Z		IDLER GEAR 2ND G 30-T	1
13	800.33.014.025	LOSRAD 4.G 25-Z		IDLER GEAR 4TH G 25-T	1
14	800.33.013.026	LOSRAD 3.G 26-Z		IDLER GEAR 3RD G 26-T	1
15	800.33.016.020	SCHIEBERAD 6.G 20-Z		SLIDING GEAR 6TH G 20-T	1
16	800.33.015.022	SCHIEBERAD 5.G 22-Z		SLIDING GEAR 5TH G 22-T	1
17	800.33.007.000	BÜCHSE 25X28X12		BUSHING 25X28X12	2
18	800.33.018.000	STÜTZSCHEIBE 25X30X1		STOP DISC 25X30X1	3
19	800.33.019.000	STÜTZSCHEIBE 21X28X1		STOP DISC 21X28X1	1
24	800.33.014.000	DISTANZBÜCHSE 11MM	03	SPACER BUSHING 11MM	03 1
26	0760 304270	WELLENDICHTRI.30X42X7 BAU2SLX2		SH.SEAL RING 30X42X7 BAU2SLX2	1
27	0625 062034	RILLENKUGELL. 6203 JR C3		BALL BEARING 6203 JR C3	1
28	490.30.023.000	ZYLINDERROLLENLAG. NJ205		CYL.ROLL BEARING NJ205	1
29	800.33.029.013	KETTENRAD 13-Z	03	SPROCKET 13-T	03 1
29	800.33.029.014	KETTENRAD 14-Z	03	SPROCKET 14-T	03 1
29	800.33.029.015	KETTENRAD 15-Z	03	SPROCKET 15-T	03 1
29	800.33.029.016	KETTENRAD 16-Z	03	SPROCKET 16-T	03 1
31	0770 022016	O-RING 22,10X1,60 NBR 70 SH		O-RING 22,10X1,60 NBR 70 SH	1
38	500.33.098.000	NADELKRANZ K20X24X10		NEEDLE BEARING K20X24X10	1
39	0405 222613	NADELKRANZ K 22X26X13 TN		NEEDLE BEAR. K 22X26X13 TN	1
45	0417 025000	SPRENGRING SW25		CIRCLIP SW25	3
46	0471 250120	SICHERUNGSRING DIN0471-25X1,2		CIRCLIP DIN0471-25X1,2	1

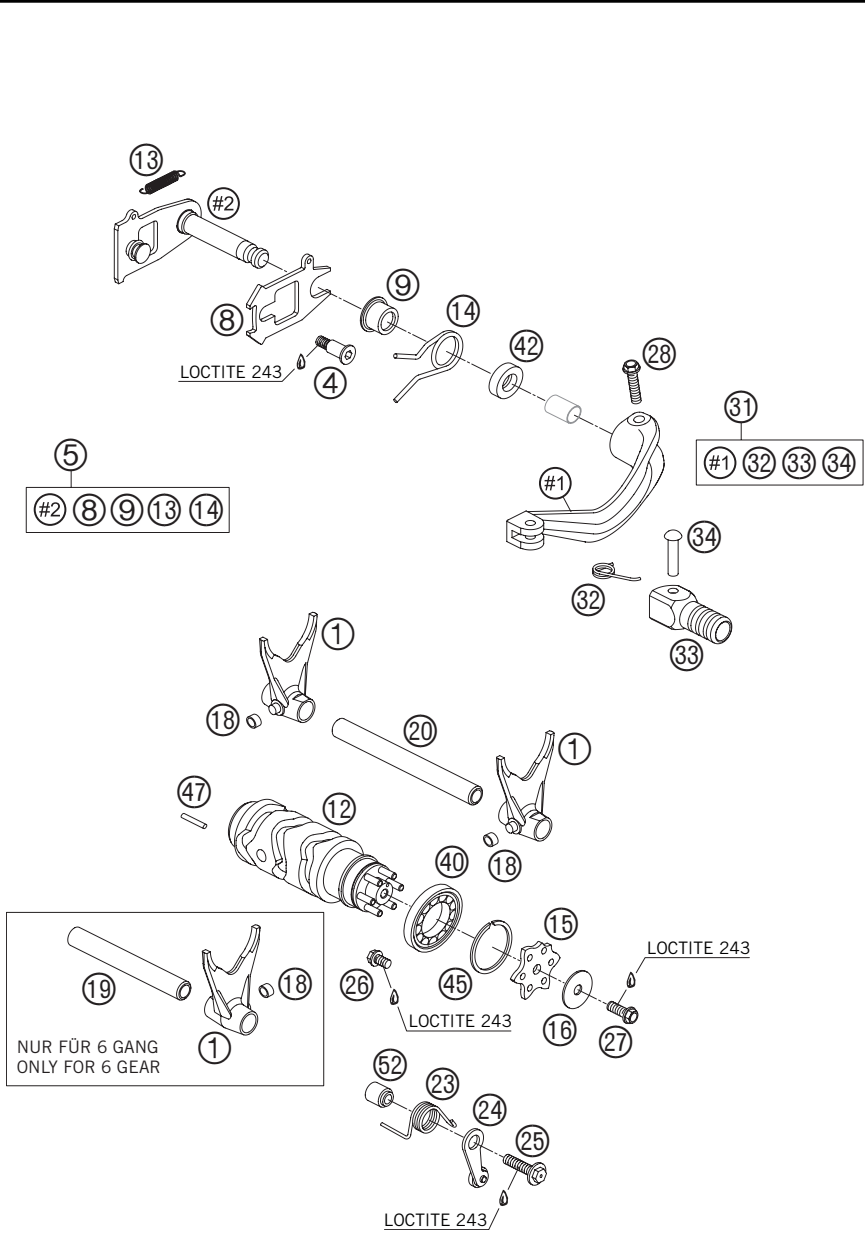
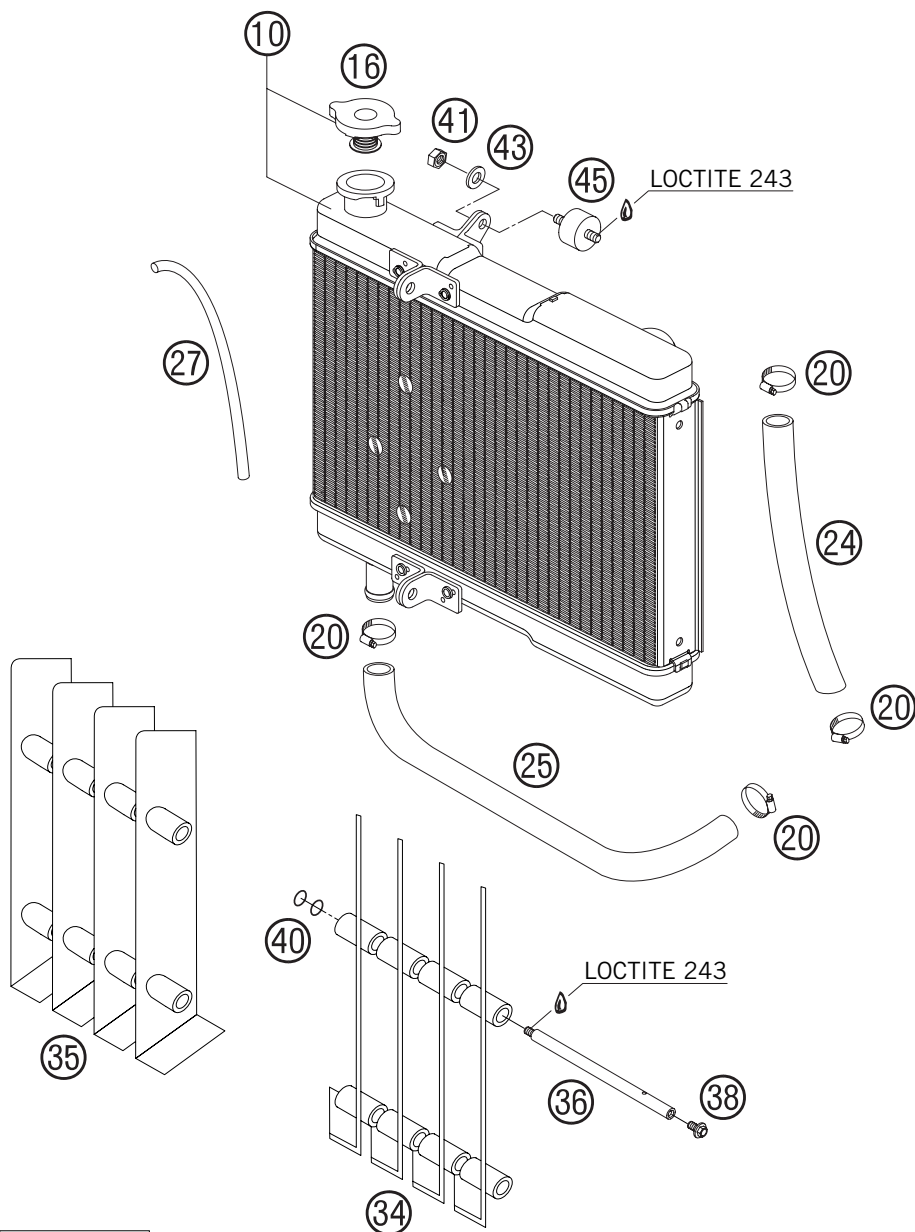

FIG	TEILNR/PARTNR	BEZEICHNUNG	DESCRIPTION	QTY
1	800.34.001.000	SCHALTGABEL 03	SHIFTING FORK 03	3(2)
4	800.34.014.050	SONDERSCHRAUBE RÜCKHOLFEDER	SPECIAL SCREW RETAINING SPRING	1
5	800.34.005.000	SCHALTWELLE KPL. 03	SHIFTING SHAFT CPL. 03	1
8	800.34.008.000	GLEITBLECH 03	SLIDING PLATE 03	1
9	800.34.009.000	FEDERFÜHRUNG 03	SPRING GUIDE 03	1
12	800.34.012.000	SCHALTWALZE 03	SHIFTING DRUM 03	1
13	800.34.013.000	SPANNFEDER 03	TENSIONING SPRING 03	1
14	800.34.014.000	RÜCKHOLFEDER 03	RETAINING SPRING 03	1
15	800.34.015.000	ARRETIERSTERN 03	POSITIONING STAR 03	1
16	800.34.015.150	ARRET. STERNSCHEIBE 6,4X24X1,2	WASHER POS. STAR 6,4X24X1,2	1
18	503.34.018.100	SCHALTROLLE 6X8X5,2	SHIFTING ROLLER 6X8X5,2	3(2)
19	800.34.019.000	SCHALTSCHIENE ANTR. 03	SHIFT RAIL MAIN SHAFT 03	1
20	800.34.020.000	SCHALTSCHIENE ABTR. 03	SHIFT RAIL COUNTERSHAFT 03	1
23	800.34.023.000	ARRETIERHEBELFEDER 03	SPRING FOR LOCKING LEVER 03	1
24	800.34.024.000	ARRETIERHEBEL KPL. 03	LOCKING LEVER CPL. 03	1
25	800.34.024.050	SONDERSCHRAUBE M 6X25	SPECIAL SCREW M 6X25	1
26	0015 060103	SK.BUNDSCHRAUBE M 6X10 SW=8	HH COLLAR SCREW M 6X10 WS=8	1
27	0015 060163	SK.BUNDSCHRAUBE M 6X16 SW=8	HH COLLAR SCREW M 6X16 WS=8	1
28	0015 060253	SK.BUNDSCHRAUBE M 6X25 SW=8	HH COLLAR SCREW M 6X25 WS=8	1
31	800.34.031.000	SCHALTHEBEL KPL. 03	SHIFTING LEVER CPL. 03	1
32	546.34.032.100	SCHALTHEBELFEDER 250	SHIFTING LEVER SPRING 250	1
33	546.34.131.000	AUFTRITT FÜR SCHALTHEBEL 250	STEP PLATE FOR SHIFT LEVER 250	1
34	546.34.031.050	BOLZEN 6X25 FÜR SCHALTHEBEL	BOLT 6X25 FOR SHIFT LEVER	1
40	0625 068060	RILLENKUGELLAGER 6806 C3	BALL BEARING 6806 C3	1
42	0760 122270	WELLENDICHTRING 12 X 22 X 7 B	SHAFT SEAL RING 12 X 22 X 7 B	1
45	800.34.012.050	SPRENGRING SW30X1,5	CIRCLIP SW30X1,5	1
47	0481 030220	SPANNSTIFT DIN1481 3X22 NUR FÜR 4 GANG	TENSION PIN DIN1481 3X22 ONLY FOR 4 GEAR	1
52	800.34.052.000	HÜLSE FÜR ARRETIERHEBEL 03	SLEEVE FOR LOCKING LEVER 03	1

FIG	TEILNR/PARTNR	BEZEICHNUNG	DESCRIPTION	QTY
10*	800.35.010.100	KÜHLER "45493B" 2006	RADIATOR "45493B" 2006	1
16	580.35.016.000	KÜHLERVERSCHLUSS KLEIN 1,4 BAR	RADIATOR CAP SMALL 20,3 PSI	1
20	100.01.020.000	SCHLAUCHKLEMME GEMI 16-27	HOSE CLAMP GEMI 16-27	4
24	800.35.024.200	KÜHLERSCHLAUCH ZYL. 650 04 650 FS-C	RADIATOR HOSE CYL. 650 04 650 FS-C	1
25	800.35.025.000	KÜHLERSCHLAUCH WASSERPUMPE 04	RADIAT. HOSE WAPU-RADIATOR 04	1
27	310.07.107.001	PVC-SCHLAUCH 6X9 MM PER METER	PVC-HOSE 6X9 MM PER METER	0,625
34	800.35.034.000	KÜHLERSCHUTZ LINKS 04	RADIATOR PROTECTOR L/S 04	4
35	800.35.035.000	KÜHLERSCHUTZ RECHTS 04	RADIATOR PROTECTOR R/S 04	4
36	800.35.036.000	HALTEBOLZEN KÜHLERSCHUTZ 04	BOLT FOR RADIAT. PROTECTOR 04	4
38	0014 060103	SK.BUNDSCHRAUBE M 6X10 SW=8	HH COLLAR SCREW M 6X10 WS=8	2
40	0770 010015	O-RING 10,00X1,50 NBR 70	O-RING 10,00X1,50 NBR 70 SH	8
41	0985 060003	SS.MUTTER DIN0985-M 6	SELF LOCK. NUT DIN0985-M 6	3
43	0021 060003	SCHEIBE DIN 9021 A 6,4	WASHER DIN9021-A 6,4	3
45	800.35.005.000	SILENTBLOCK 25X15-M6X10/15 04	VIBRAT. DAMP. 25X15M6X10/15 04	3



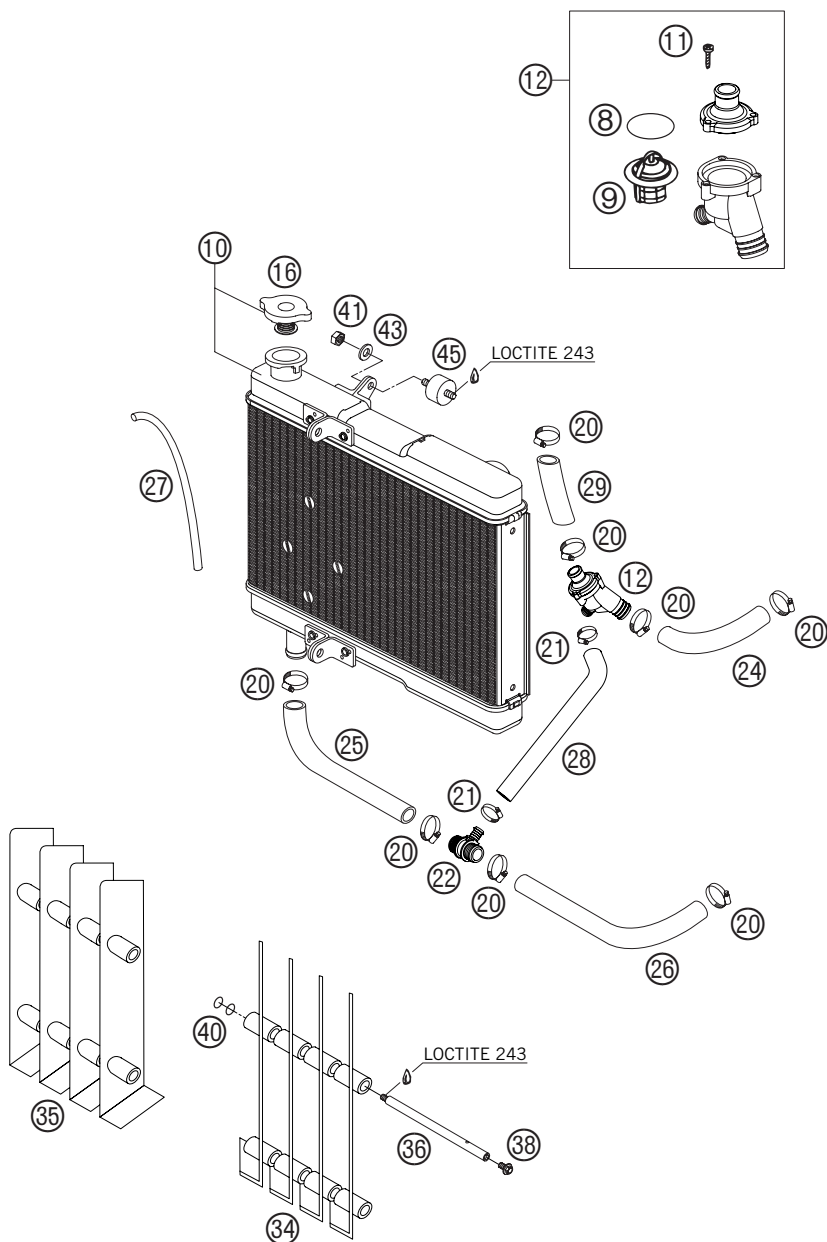

FIG	TEILNR/PARTNR	BEZEICHNUNG	DESCRIPTION	QTY
8	0770 320020	O-RING 32,00X2,00	O-RING 32,00X2,00	1
9	594.35.017.000	THERMOSTAT 70 GRAD 04	THERMOSTAT 70 DEGREES 04	1
10*	800.35.010.100	KÜHLER "45493B" 2006	RADIATOR "45493B" 2006	1
11	0016 040183	SCHRAUBE FÜR KUNSTSTOFF D=4X18	SCREW FOR PLASTIC D=4X18	3
12	800.35.013.044	THERMOSTAT KPL 05	THERMOSTAT CPL. 2005	1
16	580.35.016.000	KÜHLERVERSCHLUSS KLEIN 1,4 BAR	RADIATOR CAP SMALL 20,3 PSI	1
20	100.01.020.000	SCHLAUCHKLEMME GEMI 16-27	HOSE CLAMP GEMI 16-27	8
21	583.35.099.000	SCHLAUCHKLEMME GEMI 10-16	HOSE CLAMP GEMI 10-16	2
22	800.35.027.004	T-STÜCK 05	T-CONNECTOR 05	1
24	810.35.024.000	SCHLAUCH ZYL.-THERMOST. 450 05	HOSE CYLINDER-THERMOST. 450 05	1
24	815.35.024.000	SCHLAUCH ZYL.-THERMOST. 550 05	HOSE CYLINDER-THERMOST. 550 05	1
24	820.35.024.000	SCHLAUCH ZYL.-THERMOSTAT 650	HOSE CYLINDER-THERMOSTAT 650	1
25	800.35.027.002	FORMSCHLAUCH 2 THERMOSTAT 05	HOSE 2 THERMOSTAT 05	1
26	800.35.027.001	FORMSCHLAUCH 1 THERMOSTAT 05	HOSE 1 THERMOSTAT 05	1
27	310.07.107.001	PVC-SCHLAUCH 6X9 MM PER METER	PVC-HOSE 6X9 MM PER METER	0,625
28	800.35.027.003	FORMSCHLAUCH 3 THERMOSTAT 05	HOSE 3 THERMOSTAT 05	1
29	800.35.026.000	SCHLAUCH THERMOST. -KÜHLER 05	HOSE THERMOSTAT- RADIATOR 05	1
34	800.35.034.000	KÜHLERSCHUTZ LINKS 04	RADIATOR PROTECTOR L/S 04	4
35	800.35.035.000	KÜHLERSCHUTZ RECHTS 04	RADIATOR PROTECTOR R/S 04	4
36	800.35.036.000	HALTEBOLZEN KÜHLERSCHUTZ 04	BOLT FOR RADIAT. PROTECTOR 04	4
38	0014 060103	SK.BUNDSCHRAUBE M 6X10 SW=8	HH COLLAR SCREW M 6X10 WS=8	2
40	0770 010015	O-RING 10,00X1,50 NBR 70	O-RING 10,00X1,50 NBR 70 SH	8
41	0985 060003	SS.MUTTER DIN0985-M 6	SELF LOCK. NUT DIN0985-M 6	3
43	0021 060003	SCHEIBE DIN 9021 A 6,4	WASHER DIN9021-A 6,4	3
45	800.35.005.000	SILENTBLOCK 25X15-M6X10/15 04	VIBRAT. DAMP. 25X15M6X10/15 04	3

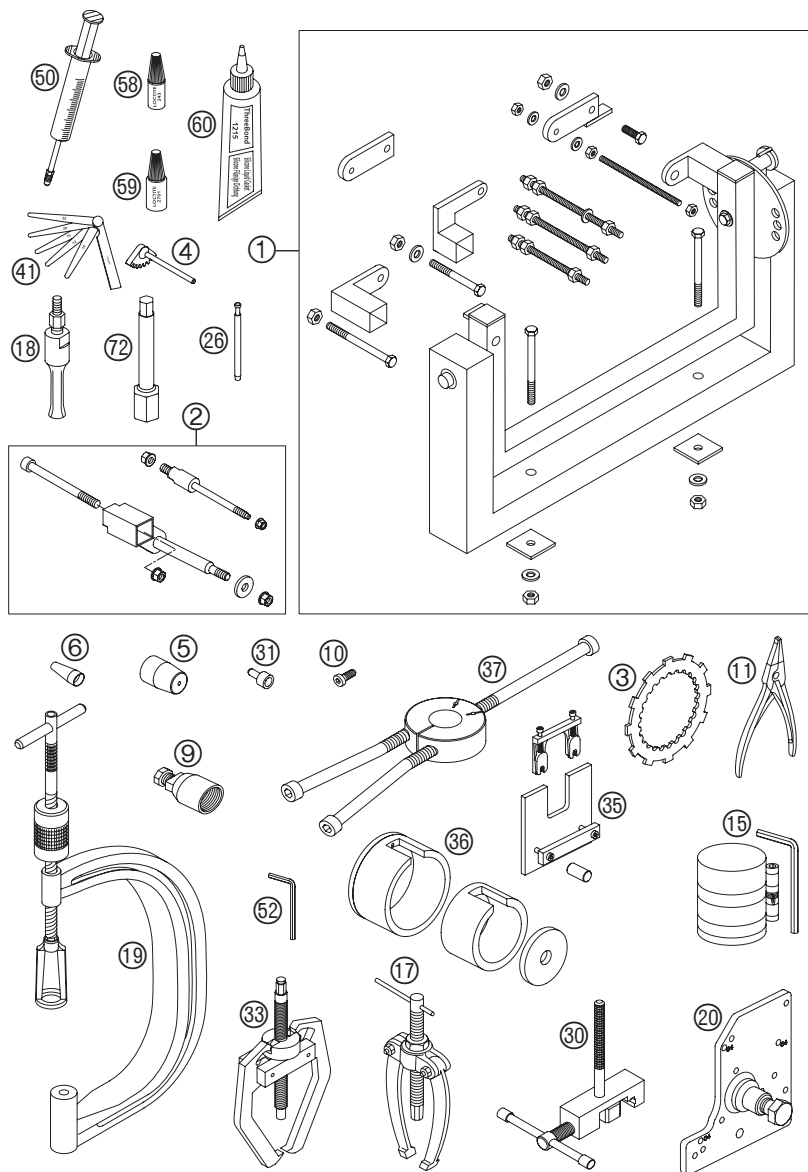

FIG	TEILNR/PARTNR	BEZEICHNUNG	DESCRIPTION	QTY
1	560.12.001.000	UNIVERSALMONTAGEBOCK '96	UNIVERSAL MOUNTING RACK '96	1
2*	800.29.002.100	MOTORHALTER HUSABERG 04	ENGINE HOLDER HUSABERG 04	1
3	800.29.003.000	KUPPLUNGSHALTER 04	CLUTCH HOLDER 04	1
4	800.29.004.000	ZAHNSEGMENT KPL. 04	GEAR SEGMENT CPL. 04	1
5	800.29.005.000	MONTAGEHÜLSE F. LINKEN WDR KW	MOUNT.SLEEVE F. LEFT SSR C.S.	1
5	800.29.105.000	MONTAGEHÜLSE F. RECHTEN WDR KW	MOUNT.SLEEVE F. RIGHT SSR C.S.	1
5	800.29.205.000	MONTAGEHÜLSE F. WDR KICKST.-W.	MOUNT.SLEEVE F. SSR KICKST.-S.	1
6	590.29.005.010	MONTAGEHÜLSE WELLENDICHTRING	MOUNTING SLEEVE SEAL RING	1
9	580.12.009.000	SCHWUNGRADABZIEHER	FLYWHEEL EXTRACTOR	1
10	580.30.080.000	FIXIERSCHRAUBE M8 L=23	LOCATING SCREW M8 L=23	1
11	510.12.011.000	SEEGERRINGZANGE VERKEHRT	SPECIAL CIRCLIP PLIER	1
15	600.29.015.000	KOLBENRINGSPANNBAND KPL. 03	PISTON RING COMPRESSOR CPL. 03	1
17	151.12.017.000	LAGERAUSZIEHER	BUSHING EXTRACTOR	1
18	151.12.018.000	EINSATZ 12-16 MM	INTERN.BEAR.PULLER 12-16 MM	1
19	590.29.019.000	VENTILFEDERHEBER	VALVE SPRING LEVER	1
20	800.29.020.000	GEHÄUSETRENNWERKZEUG 04	HOUSING SEPARATING TOOL 04	1
26	590.29.026.006	GRENZLEHRDORN F.VENTILFÜHRUNG	LIMIT PLUG GAUGE F.VALVE GUIDE	1
30	800.29.030.000	NIETWERKZEUG STEUERKETTE KPL.	RIVETTING TOOL TIMING CHAIN	1
31	800.29.031.000	SCHUTZKAPPE FÜR KURBELWELLE	PROTECTION COVER F. CRANKSHAFT	1
33	590.29.033.000	ZWEIBACK.ABZIEHER STEUERRITZEL	EXTRACTOR FOR TIMING GEAR	1
35*	800.29.035.000	AUSPRESSWERKZEUG KURBELW. KPL.	PRESS OUT TOOL CONROD BEARING	1
36*	800.29.036.000	EINPRESSWERKZEUG KURBELW. KPL.	PRESS IN TOOL CONROD BEARING	1
37	584.29.037.037	MONTAGEW.F.LAGERINNENR. NJ206	MOUNTING TOOL INNER RING NJ206	1
41	590.29.041.000	FÜHLERLEHRENSET 10,12,15,20,25	FEEL. GAUGE SET 10,12,15,20,25	1
50	503.29.050.000	ENTLÜFT.SPITZHE HYDR. KUPPLUNG	VENT INJEKTION HYDR. CLUTCH	1
52*	800.29.052.000	SICHERHEITSTORX TX20	SAFETY-TORX TX20	1
58	6 899 785	LOCTITE 243 BLAU 6CCM	LOCTITE 243 BLUE 6CCM	1
59	800.29.059.000	LOCTITE 2701 GRÜN 5ML	LOCTITE 2701 GREEN 5ML	1
60	309098	SILIKONDICHTMASSE THREE-BOND	SILICON GASKET THREE-BOND	1
72	590.29.072.000	ZÜNDKERZENSCHLÜSSEL 13/16	SPARK PLUG WRENCH 13/16	1

HUSABERG
4STROKEFORCE

HUSABERG - a company of the KTM Group
Stallhofnerstraße 3, A-5230 Mattighofen
E-mail: info@husaberg.cc, Internet: www.husaberg.cc

